

JLR-8600
NWZ-1650

GPS NAVIGATOR

**INSTRUCTION
MANUAL**

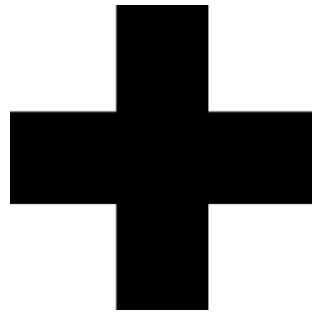

Cautions for High Voltage

High voltage of hundreds volts is used inside this equipment. Touching a component inside the unit is very dangerous. Any person other than specialized maintenance staffs should not maintain, inspect, or adjust the unit.

High voltages on the order of tens of thousand volts are most likely to cause instant deaths from electrical shocks. At times, even voltages on the order of several hundred volts could lead to electrocution. To defend against electrical shock hazards, do not put your hand into the inside of apparatus.

When you put in a hand unavoidably in case of urgent, it is strongly suggested to turn off the power switch and allow the capacitors, etc. to discharge with a wire having its one end positively grounded to remove residual charges. Before you put your hand into the inside of apparatus, make sure that internal parts are no longer charged. Extra protection is ensured by wearing dry cotton gloves at this time.

Another important precaution to observe is to keep one hand in your pocket at a time, instead of using both hands at the same time. It is also important to select a secure footing to work on, as the secondary effects of electrical shock hazards can be more serious. In the event of electrical shocks, disinfect the burnt site completely and obtain medical care immediately.

Precautions for Rescue of Victim of Electric Shock

When a victim of electric shock is found, turn off the power source and ground the circuit immediately. If this is impossible, move the victim away from the unit as quick as possible without touching him or her with bare hands. He or she can safely be moved if an insulating material such as dry wood plate or cloth is used.

It is necessary to perform first aid immediately.

Breathing may stop if current flows through the respiration center of brain due to electric shock. If the electric shock is not large, breathing can be restored by artificial respiration. A victim of electric shock looks pale and his or her pulse may become very weak or stop, resulting in unconsciousness and rigidity at worst.

Method of First-Aid Treatment

☆ Precautions for First-Aid Treatments

Apply artificial respiration to the person who collapsed, minimizing moving as much as possible avoiding risks. Once started, artificial respiration should be continued rhythmically.

- (1) Refrain from touching the patient carelessly as a result of the accident; the first-aiders could suffer from electrical shocks by himself or herself.
- (2) Turn off the power calmly and certainly, and move the patient apart from the cable gently.
- (3) Call or send for a physician or ambulance immediately, or ask someone to call doctor.
- (4) Lay the patient on the back, loosening the necktie, clothes, belts and so on.
- (5)
 - (a) Feel the patient's pulse.
 - (b) Check the heartbeat by bringing your ear close to the patient's heart.
 - (c) Check for respiration by bringing your face or the back of your hand to the patient's face.
 - (d) Check the size of patient's pupils.
- (6) Opening the patient's mouth, remove artificial teeth, cigarettes, chewing gum, etc. if any. With the patient's mouth open, stretch the tongue and insert a towel or the like into the mouth to prevent the tongue from being withdrawn into the throat. (If the patient clenches the teeth so tight that the mouth won't open, use a screwdriver or the like to force the mouth open and then insert a towel or the like into the mouth.)
- (7) Wipe off the mouth to prevent foaming mucus and saliva from accumulating.

★ Treatment to Give When the Patient Has a Pulse Beating but Has Ceased to Breathe

* Performing mouth-to-mouth artificial respiration

- (1) Bend the patient's face backward until it is directed to look back. (A pillow may be placed under the neck.)
- (2) Pull up the lower jaw to open up the airway. (To spread the airway)
- (3) Pinching the patient's nose, breathe deeply and blow your breath into the patient's mouth strongly, with care to close it completely. Then, move your mouth away and take a deep breath, and blow into his or her mouth. Repeat blowing at 10 to 15 times a minute (always with the patient's nostrils closed).
- (4) Continue artificial respiration until natural respiration is restored.
- (5) If the patient's mouth won't open easily, insert a pipe, such as one made of rubber or vinyl, into either nostril. Then, take a deep breath and blow into the nostril through the pipe, with the other nostril and the mouth completely closed.
- (6) The patient may stand up abruptly upon recovering consciousness. Keep the patient lying calmly, giving him or her coffee, tea or any other hot drink (but not alcoholic drink) to keep him or her warm.

Mouth-to-mouth artificial respiration with the patient's head lifted

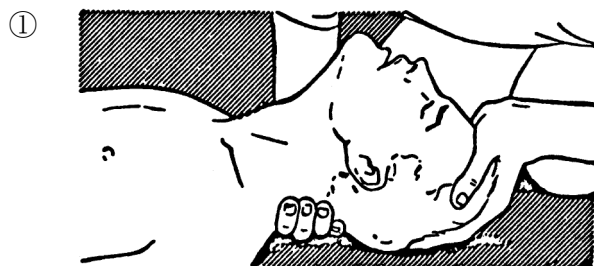

- (1) Lift the back part of the patient's head. Support the forehead with one of your hand and the neck with the other hand. → [1]. Many patients will have their airways opened by lifting their head in this way to ease mouth-to-mouth artificial respiration.

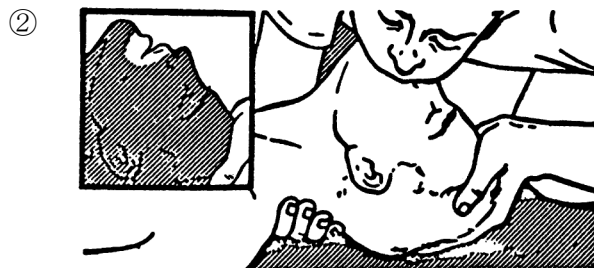

- (2) Closing the patient's mouth you're your mouth, press your cheek against the patient's nose → [2]. Alternatively, hold the patient's nose with your finger to prevent air leak → [3].



- (3) Blowing air into the patient's lungs. Blow air into the patient's lungs until chest is seen to rise. The first 10 breaths must be blown as fast as possible.

Fig. 1 Mouth-to-mouth artificial respiration

Flow of Cardiopulmonary Resuscitation (CPR)

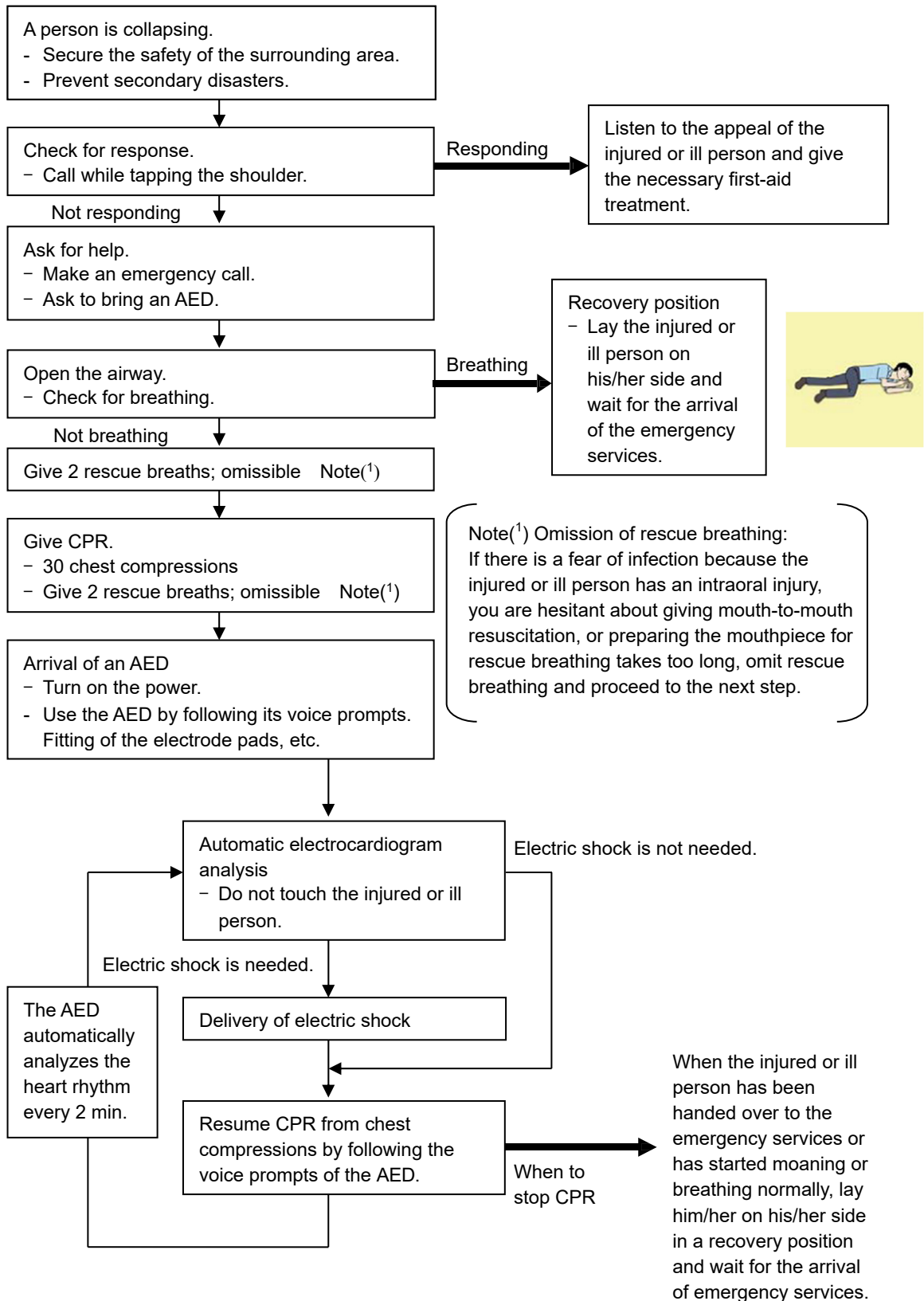

Specific Procedures for Cardiopulmonary Resuscitation (CPR)

1. Check the scene for safety to prevent secondary disasters

- a) Do not touch the injured or ill person in panic when an accident has occurred. (Doing so may cause electric shock to the first-aiders.)
- b) Do not panic and be sure to turn off the power. Then, gently move the injured or ill person to a safe place away from the electrical circuit.

2. Check for responsiveness

- a) Tap the shoulder of the injured or ill and shout in the ear saying, "Are you OK?"
- b) If the person opens his/her eyes or there is some response or gesture, determine it as "responding." But, if there is no response or gesture, determine it as "not responding."



3. If responding

- a) Give first-aid treatment.

4. If not responding

- a) Ask for help loudly. Ask somebody to make an emergency call and bring an AED.
 - **Somebody has collapsed. Please help.**
 - **Please call an ambulance.**
 - **Please bring an AED.**
 - If there is nobody to help, call an ambulance yourself.

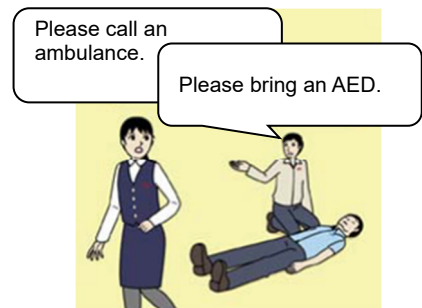

5. Open the airway

- a) Touch the forehead with one hand. Lift the chin with the two fingers of the middle finger and forefinger of the other hand and push down on the forehead as you lift the jaw to bring the chin forward to open the airway. If neck injury is suspected, open the airway by lifting the lower jaw.

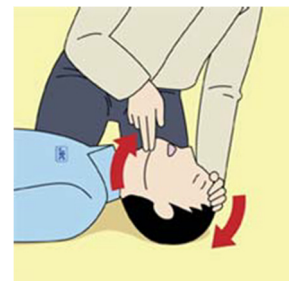

6. Check for breathing

- a) After opening the airway, check quickly for breathing for no more than 10 seconds. Put your cheek down by the mouth and nose area of the injured or ill person, look at his/her chest and abdomen, and check the following three points.
 - Look to see if the chest and abdomen are rising and falling.
 - Listen for breathing.
 - Feel for breath against your cheek.

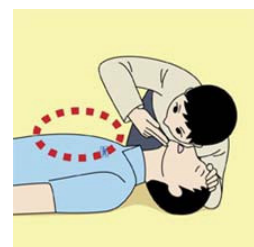

- b) If the injured or ill person is breathing, place him/her in the recovery position and wait for the arrival of the emergency services.
- Position the injured or ill person on his/her side, maintain a clear and open airway by pushing the head backward while positioning their mouth downward. To maintain proper blood circulation, roll him/her gently to position them in the recovery position in the opposite direction every 30 minutes.

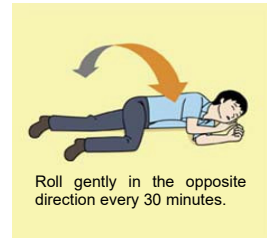

7. Give 2 rescue breaths (omissible)

- a) If opening the airway does not cause the injured or ill person to begin to breathe normally, give rescue breaths.
- b) If there is a fear of infection because the injured or ill person has an intraoral injury, you are hesitant about giving mouth-to-mouth resuscitation, or getting and preparing the mouthpiece for rescue breathing takes too long, omit rescue breathing and perform chest compressions.
- c) When performing rescue breathing, it is recommended to use a mouthpiece for rescue breathing and other protective devices to prevent infections.
- d) While maintaining an open airway, pinch the person's nose shut with your thumb and forefinger of the hand used to push down the forehead.
- e) Open your mouth widely to completely cover the mouth of the injured or ill person so that no air will escape. Give rescue breathing **twice in about 1 second** and check if the chest rises.



8. Cardiopulmonary resuscitation (CPR) (combination of chest compressions and rescue breaths)

- a) Chest compressions
- 1) Position of chest compressions
- Position the heel of one hand in the center of the chest, approximately between the nipples, and place your other hand on top of the one that is in position.

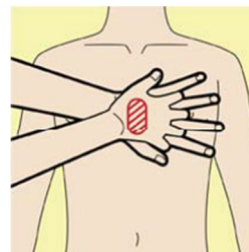
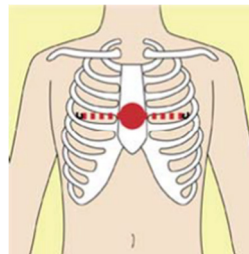
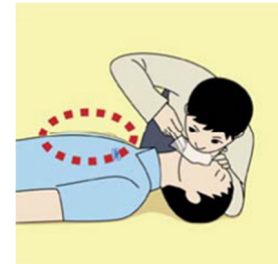

- 2) Perform chest compressions
- Perform uninterrupted chest compressions of **30** at the rate of about **100 times** per minute. While locking your elbows positioning yourself vertically above your hands.
 - With each compression, depress the chest wall to a depth of approximately **4 to 5 cm**.

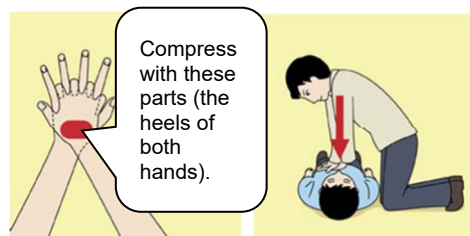

b) Combination of **30** chest compressions and **2** rescue breaths

- 1) After performing **30** chest compressions, give **2** rescue breaths. If rescue breathing is omitted, perform only chest compressions.
- 2) Continuously perform the combination of **30** chest compressions and **2** rescue breaths without interruption.
- 3) If there are two or more first-aiders, alternate with each other approximately every **two minutes** (five cycles of compressions and ventilations at a ratio of 30:2) without interruption.

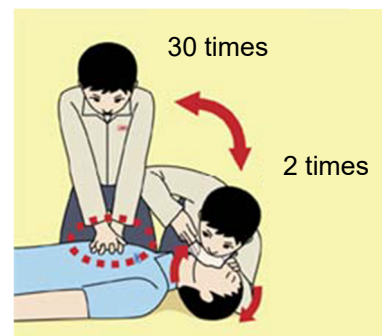

9. When to stop cardiopulmonary resuscitation (CPR)

- a) When the injured or ill person has been handed over to the emergency services
- b) When the injured or ill person has started moaning or breathing normally, lay him/her on his/her side in a recovery position and wait for the arrival of emergency services.



10. Arrival and preparation of an AED

- a) Place the AED at an easy-to-use position. If there are multiple first-aiders, continue CPR until the AED becomes ready.
- b) Turn on the power to the AED unit. Depending on the model of the AED, you may have to push the power on button, or the AED automatically turns on when you open the cover.
- c) Follow the voice prompts of the AED.

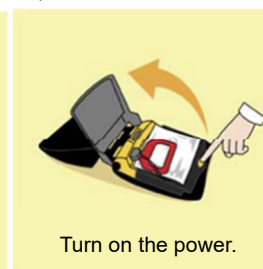

11. Attach the electrode pads to the injured or ill person's bare chest

- a) Remove all clothing from the chest, abdomen, and arms.
- b) Open the package of electrode pads, peel the pads off and securely place them on the chest of the injured or ill person, with the adhesive side facing the chest. If the pads are not securely attached to the chest, the AED may not function. Paste the pads exactly at the positions indicated on the pads. If the chest is wet with water, wipe dry with a dry towel and the like, and then paste the pads. If there is a pacemaker or implantable cardioverter defibrillator (ICD), paste the pads at least 3cm away from them. If a medical patch or plaster is present, peel it off and then paste the pads. If the injured or ill person's chest hair is thick, paste the pads on the chest hair once, peel them off to remove the chest hair, and then paste new pads.
- c) Some AED models require to connect a connector by following voice prompts.
- d) The electrode pads for small children should not be used for children over the age of 8 and for adults.

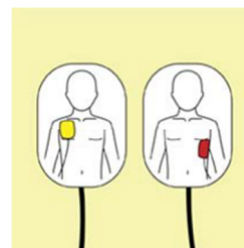

12. Electrocardiogram analysis

- a) The AED automatically analyzes electrocardiograms. Follow the voice prompts of the AED and ensure that nobody is touching the injured or ill person while you are operating the AED.
- b) On some AED models, you may need to push a button to analyze the heart rhythm.



13. Electric shock (defibrillation)

- a) If the AED determines that electric shock is needed, the voice prompt saying, "Shock is needed" is issued and charging starts automatically.
- b) When charging is completed, the voice prompt saying, "Press the shock button" is issued and the shock button flashes.
- c) The first-aider must get away from the injured or ill person, make sure that no one is touching him/her, and then press the shock button.
- d) When electric shock is delivered, the body of the injured or ill person may jerk.



14. Resume cardiopulmonary resuscitation (CPR).

Resume CPR consisting of **30** chest compressions and **2** rescue breaths by following the voice prompts of the AED.



15. Automatic electrocardiogram analysis

- a) When **2 minutes** have elapsed since you resumed cardiopulmonary resuscitation (CPR), the AED automatically analyzes the electrocardiogram.
- b) If you suspended CPR by following voice prompts and AED voice prompt informs you that shock is needed, give electric shock again by following the voice prompts.
If AED voice prompt informs you that no shock is needed, immediately resume CPR.

16. When to stop CPR (Keep the electrode pads on.)

- a) When the injured or ill person has been handed over to the emergency services
- b) When the injured or ill person has started moaning or breathing normally, lay him/her on his/her side in a recovery position and wait for the arrival of emergency services.



Foreword

Thank you for purchasing the JRC GPS Navigator JLR-8600.

This equipment is a high-performance navigation equipment consisting of a GPS sensor and navigator, can retrieve the position data using the GPS sensor to display various navigation information on the display.

- Thoroughly read this instruction manual before operating the equipment.
- Keep this manual nearby the equipment to allow ready access to it if necessary. It may provide valuable information on how to deal with a given situation that may arise during the operation.

Before Commencing the Operation

Symbols

Several symbols are used in this manual to ensure safety and proper operation of the equipment and to avoid possible human injury or property damage. These symbols and their meanings are shown below. Please read and understand these symbols before proceeding to read this manual.



WARNING

Instructions shown with this symbol represent what can cause death or serious injury if not observed.



CAUTION

Instructions shown with this symbol represent what may cause injury or property damage if not observed.

Examples of the Symbols



The symbols shown in the Δ mark represent those that require attention (including potential dangers and warnings). A depiction of the type of caution is shown inside the symbol (the left symbol indicates a general caution).



The symbols shown in the \odot mark represent actions which are prohibited. A depiction of the type of prohibited action is shown inside the symbol (the left symbol indicates that disassembly is prohibited).



The \bullet symbol indicates required actions. A depiction of the type of required action is shown inside the symbol (the left symbol indicates that the power plug must be disconnected from the outlet).

Precautions Upon the Operation

WARNING



Do not disassemble or modify the equipment. Doing so may result in fire, electric shock, or equipment failure.



Do not allow the display to become wet. Doing so may result in fire, electric shock, or equipment failure.



Operate the equipment only at the indicated voltage. Failure to do so may result in fire, electric shock, or equipment failure.



Install this unit at least 1 m away from any magnetic compasses. Installation near a magnetic compass may result in interference with the magnetic compass, and may result in an accident.



Do not perform internal inspections or modifications of the equipment. Inspection or modification by unauthorized personnel may result in fire, electric shock, or equipment failure.



Please consult with JRC or an affiliate to perform internal inspections or repair.



When disposing of the used lithium battery, place insulating tape over the battery terminals, or otherwise insulate the battery. Failure to do so may result in heating, explosion, or fire due to a shorted battery.



In case you find smoke, unusual odor or extreme high heat coming from the equipment, turn off the power and breaker immediately.
After that, please contact your dealer or agency or each branch office / head office / local office.
Keeping operation under such condition may cause fire or electric shock.



CAUTION



The navigation information including the position data needs to be judged by the user himself. This equipment is not designed to automatically make judgments on the position data.



Do not use the equipment in the environment other than those provided in the specification. Doing so may result in equipment failure, malfunction, or injury.



Do not install the display unit in the location where it may come in contact with water, oil, or chemicals. Doing so may result in equipment failure, malfunction, or injury.



Do not install the equipment in the place subject to vibration or shock. Doing so may result in the equipment falling or collapsing, resulting in equipment failure or injury.



Do not place any item on the top of the equipment. Doing so may result in equipment failure, malfunction, or injury.



Please consult with JRC or an affiliate to perform installation. Installation by unauthorized personnel may result in malfunction.



Use only the specified battery. Failure to do so may result in battery leakage or rupture, resulting in fire, injury, or equipment failure.



Do not use benzine, alcohol or thinner when caring this equipment. Doing so may result in removing the paint or changing of properties.



Wipe off the grime lightly with a dry soft cloth. Wipe with the other than a dry soft cloth may result in equipment injury.



Use the indicated screws when installing the display unit to a stable wooden surface. Failure to do so may result in the display unit falling over, causing injury or property damage.



Use only the specified fuse. Failure to do so may result in fire or equipment failure.









Use only the specified battery. Failure to do so may result in equipment failure or malfunction.



Do not use a sharp tip, when tapping the touch panel. Doing so may result in screen injury.



CAUTION

-  When connecting the cable attached to the equipment, do not bend it acutely, twist it, or impart excessive force. Doing so sometimes causes cracks or damage to the coating, resulting in fire or electrocution.
-  Do not install the sensor where there is excessive vibration. Vibration may cause sensor failure.
-  Do not paint the sensor. Doing so may result in reception problems.
-  Do not install the sensor where temperature exceeds 55 degrees Celsius and there is covered with exhaust gas from funnel. Doing so may result in equipment failure or malfunction.
-  Use a fitted cable, when connected to junction box. The junction box rubber gaskets (25 f Gland side) fit ϕ 10mm – 20mm cables.
-  Install the sensor where there are no obstacles, in order to ensure that GPS signals can be directly received from satellites without interference or reflection of signals from surrounding objects. Whenever possible, select a place with the following characteristics.

- 1. An open space, which allows uniform reception of satellite signals.**
- 2. Far away from any high power transmission antennas.**
- 3. Outside radar beams.**
- 4. Away from the INMARSAT antenna by at least 5 meters and outside the INMARSAT beam.**
- 5. Away from the antenna of a VHF transmitter and a direction finder by at least 3 meters.**
- 6. Away from a Magnetic Compass by at least 1 meter.**
- 7. Away from amateur radio antennas by at least 3 meters.**

Every time, Confirms the proper performance of equipment can be obtained, when changing the equipment location.

If it is difficult to find an ideal site, select a place temporarily and install the equipment. Conduct a test to make sure that the proper performance can be obtained and then fix the equipment in position. If it is installed at an improper place, reception accuracy may be impaired.

-  If occurs bad positioning of such as satellite can not be received, please execute the re-start of sensor. If not recover, please consult with JRC or an affiliate
-  There are cases when time lags in the gps navigator and gps compass. This is not a malfunction due to the delay in the internal processing.
-  There are cases when time lags in the main display unit and sub display unit. This is not a malfunction due to the delay in the internal processing.

Appearance of the Equipment

●NWZ-1650 Display Unit



●NDC-4100 Processor Unit



●JLR-4350 GPS Sensor Unit



Terminology

Term	Meaning (Descriptions)
2D (2 dimension)	Positioning with antenna elevation height in addition to satellite data.
3D (3 dimension)	The three dimensional position fix, 4 or more satellites required.
Active route	Route that is currently used by a ship
Anchor alert	This alert monitors that the own ship is the preset distance or more away from the waypoint.
Arrival alert	This alert informs that the own ship has traveled the preset distance, approaching the waypoint.
Beacon information	Beacon data which is broadcast by message type 16.
BeiDou	BeiDou is a satellite positioning system that is managed by China.
Boundary alert	This alert informs that the own ship has got into the preset route.
CCRP	Abbreviation of Consistent Common Reference Point. Reference position of the own ship.
CDI	Abbreviation of Course Deviation Indicator. This indicator shows information on the deviation from the scheduled route and on the direction into which the ship should be steered.
Checksum	An error detection method to check that the data has been correctly transmitted.
COG	Course Over Ground.
Course	Direction in which the ship is traveling, which is the bearing mainly displayed by the GPS.
CURRENT	Sea and ocean currents, expressed in speed and direction.
Data route	Ship route data that is stored in the memory of the equipment
Default gateway	Equipment connected externally from a constructed network.
DGPS	Abbreviation of Differential Global Positioning System. GPS satellite error data sent from a reference station whose position is accurately known is received via beacon from a beacon station, improving positioning accuracy.
FRAM	Nonvolatile memory using a ferroelectric substance.
Geodetic	Conditions for expressing position via latitude and longitude.
GPS Satellite (GPS)	Abbreviation of Global Positioning System. Refers to satellites launched for navigational support of military vessels managed by the United States Department of Defense.
GLONASS	GLONASS is a satellite positioning system that is managed by Russia.
HDOP	Abbreviation of Horizontal Dilution of Precision. Indicates accuracy of positioning. The smaller the number, the higher the accuracy. If GPS satellites are unevenly distributed, this number will grow. If GPS satellites are evenly distributed, this number will be smaller.
IEC	IEC is the abbreviation of International Electrotechnical Commission. It is an international standard governing electrical and electronic technologies.
IPXX	IPXX is Degrees of protection provided by enclosures (IP Code) 1st numeral: Against ingress of solid foreign objects (0 – 6)

	2nd numeral: Against ingress of water with harmful effects (0 - 8). (IPX4: splash-proof, IPX6: waterproof)
IP address	ID number assigned to equipment on a constructed network.
LAN	Abbreviation of Local Area Network. A network is constructed for transmitting and receiving data.
LCD Unit (LCD)	Liquid Crystal Display Unit.
Leg	Line between two consecutive waypoints.
Log Pulse	Contact output signal, output in 1 pulse per nm. Expressed in units of "p/nm". mi/h Unit of ship speed.
Loran time difference display	Method for expressing the present position with loran system time difference. (The method is for operators who have a background in loran navigation.)
MAC address	ID number assigned to LAN IC
Multi GNSS	Positioning using multiple satellite systems at the same time.
Master reset	This function changes the settings of the display unit and GPS sensor back to the factory settings. The function clears all the data. To perform the master reset, please consult with JRC or an affiliate
Multipath Wave	Waves received from multiple directions due to reflection or refraction of an initial wave by obstacles.
Mutual monitoring mode	When two navigators are installed, they monitor their position fixing status each other by using this function.
NMEA0183 (NMEA)	Abbreviation of National Marine Electrical Association 0183. International standard for naval equipment transmission established by the National Marine Electrical Association.
QZSS	QZSS is a Quasi-zenith satellite system that is managed by Japan and complements GPS.
Positioning	Use of GPS or DGPS receiving functions to determine the current position of a ship.
RAIM Accuracy Standard (RAIM)	Abbreviation of Receiver Autonomous Integrity Monitoring. This system automatically detects failed satellites and deselects their positioning data from calculations. Including data from failed satellites will result in a decrease in positioning accuracy; the RAIM accuracy standard indicates the accuracy degradation base for removal of failed satellites from positioning calculations.
Ranging	Positioning with the use of SBAS satellite in addition to GPS satellite.
Reception Level	GPS signal reception level.
Route plan	Plan registered with multiple waypoints in the navigation order
RS-232C	Serial data transmission standard. It is unbalanced, and hence can only be used for short distance transmission.
RS-422	Balanced serial transmission standard.
SBAS	Abbreviation of Satellite Based Augmentation System. It is a blanket term for wide scale GPS support systems using fixed position satellites which send GPS error correction data over a wide range.

SBAS Search	SBAS reception mode (manual / automatic).
Shared route	Function that uses the same route as other functions such as ECDIS do. The route can be updated automatically by sharing the active route.
Smoothing	Function for averaging over a specified number of seconds.
SOG	Speed Over Ground, This is the ship's relative speed to the ground.
SPEED	The speed mainly measured by the GPS.
STW	Speed Through Water.
Subnet mask	Value for identifying the network address
Symbol information	Information of symbols displayed on the plotting screen. The information includes symbol positions, comments, etc.
TD	Abbreviation of Time Difference. Time difference from the master-station signal of the loran system to the slave-station signal.
Message Type 0	SBAS satellite test broadcasting.
UTC	Abbreviation of Coordinated Universal Time.
XTD alert	This alert informs that the own ship has got out of the scheduled route by the preset distance or more.

Contents

• Safety Cautions •	i
• Emergency Measures •	ii
Foreword	x
Before Commencing the Operation	xi
Precautions Upon the Operation	xii
Appearance of the Equipment	xv
Terminology	xvi
Contents	20
Chapter 1 Equipment Overview	1-1
1.1 Functions	1-1
1.2 Features	1-1
1.3 Configuration	1-2
1.3.1 Standard Configuration	1-2
1.3.2 Option	1-3
1.4 Construction	1-4
1.5 System Diagram	1-13
Chapter 2 Name and Function of Each Unit	2-1
2.1 NWZ-1650 DISPLAY UNIT	2-1
2.2 JLR-4350 GPS Sensor	2-3
2.3 NDC-4100 Processor Unit	2-3
Chapter 3 Display Screens	3-1
3.1 Display Screens	3-1
3.1.1 Switching display	3-1
3.1.2 Navigation information screen	3-1
3.1.3 Plotting screen 1	3-5
3.1.4 Plotting screen 2	3-6
3.1.5 Analogue screen	3-7
3.1.6 Highway screen	3-8
3.1.7 Satellite information screen	3-8
3.1.8 Waypoint information screen	3-9
3.1.9 Beacon text screen	3-9
3.1.10 Navigation aid screen	3-10
Chapter 4 Operation	4-1
4.1 Menu List	4-1
4.1.1 Main Menu	4-1
4.1.2 Function menu	4-7
4.2 Basic Operation	4-8
4.2.1 Turning on the power of the unit	4-8
4.2.2 Startup	4-8
4.2.3 Turning off the power of the unit	4-9
4.2.4 Adjusting the backlight	4-10
4.2.5 Menu operation	4-10
4.2.6 Alert and acknowledgment (ACK)	4-11
4.2.7 Screen operation	4-13
4.2.8 Inputting numeric values	4-13
4.2.9 Inputting comments	4-14
4.2.10 List operation	4-15
4.2.11 Entering a password in CODE INPUT	4-15
4.3 Setting Display	4-16
4.3.1 Setting a theme	4-16
4.3.2 Setting a beep tone	4-16
4.3.3 Setting reverse video display	4-16
4.3.4 Selecting a display screen	4-17
4.4 Registering Waypoints	4-18
4.4.1 Displaying a waypoint list	4-18
4.4.2 Registering waypoints	4-19
4.4.3 Editing waypoints	4-22
4.4.4 Copying waypoints	4-22
4.4.5 Deleting waypoints	4-23

4.5	Route Plan.....	4-24
4.5.1	Displaying a route list.....	4-24
4.5.2	Creating routes.....	4-25
4.5.3	Editing routes.....	4-27
4.5.4	Copying routes.....	4-28
4.5.5	Deleting routes.....	4-29
4.5.6	Sharing a route with another piece of equipment.....	4-31
4.5.7	Setting route initial values.....	4-32
4.6	Executing a Route.....	4-34
4.6.1	Executing a route by selecting from a route list.....	4-34
4.6.2	Selecting a waypoint/route by using the GOTO key.....	4-35
4.6.3	Ending a route.....	4-38
4.7	Event/Mark.....	4-39
4.7.1	Displaying an event/mark list.....	4-39
4.7.2	Registering events.....	4-39
4.7.3	Registering marks.....	4-40
4.7.4	Editing events/marks.....	4-41
4.7.5	Deleting events/marks.....	4-41
4.8	Plotting Screen.....	4-43
4.8.1	Operating the cursor.....	4-43
4.8.2	Changing the cursor size.....	4-43
4.8.3	Moving a screen.....	4-44
4.8.4	Moving own ship to the centre of the screen.....	4-44
4.8.5	Screen Zoom In/Out.....	4-45
4.8.6	Changing North Up/Course Up.....	4-45
4.8.7	Displaying tracks.....	4-46
4.8.8	Displaying an own ship vector and a distance circle.....	4-47
4.8.9	Setting symbols to display/non-display.....	4-48
4.8.10	Displaying symbol information.....	4-48
4.8.11	Changing a background colour.....	4-49
4.9	Setting MOB.....	4-50
4.10	Setting Alerts.....	4-51
4.10.1	Setting alert/buzzer sounds for SOLAS ship.....	4-52
4.10.2	Setting alert/buzzer sounds for non-SOLAS ship.....	4-55
4.10.3	Alert setting.....	4-58
4.11	Alert List.....	4-60
4.11.1	Displaying the alert that is occurring.....	4-60
4.11.2	Displaying alert history.....	4-63
4.11.3	Displaying the alerts that occurred in LAN.....	4-63
4.12	Initial Settings of GNSS/Beacon/SBAS.....	4-65
4.12.1	Setting a positioning system.....	4-65
4.12.2	Setting a position fixing mode.....	4-66
4.12.3	Setting an elevation mask.....	4-66
4.12.4	Setting HDOP.....	4-67
4.12.5	Setting position, speed, and course smoothing.....	4-67
4.12.6	Setting RAIM.....	4-68
4.12.7	Setting a geodetic system.....	4-68
4.12.8	Initialising sensors.....	4-69
4.12.9	Setting a DGPS correction mode.....	4-69
4.12.10	Setting a beacon.....	4-71
4.12.11	Setting SBAS.....	4-72
4.12.12	Displaying a beacon station list.....	4-72
4.13	Configuring a System.....	4-73
4.13.1	Setting time difference/date display.....	4-73
4.13.2	Setting units.....	4-73
4.13.3	Setting magnetic correction.....	4-74
4.13.4	Setting LORAN A/C.....	4-74
4.13.5	Selecting a sensor.....	4-75
4.14	Printing.....	4-76
4.15	Setting a Language.....	4-76
4.16	Verifying Versions.....	4-76
4.17	Displaying a total trip distance.....	4-77
4.17.1	Starting/stopping measurement of a trip distance.....	4-77

4.17.2	Resetting a trip distance	4-77
4.17.3	Resetting a total trip distance	4-77
4.18	Measuring a trip distance	4-78
4.18.1	Starting/stopping measurement.....	4-78
4.18.2	Resetting a trip distance	4-78
4.19	Displaying external equipment information	4-79
4.20	Measuring a distance and an azimuth between two points	4-80
Chapter 5	Maintenance and Inspection.....	5-1
5.1	General Maintenance and Inspection	5-1
5.2	Alerts	5-2
5.3	Troubleshooting.....	5-9
5.4	Replacement Parts.....	5-11
5.4.1	Repair units.....	5-11
5.4.2	Regular replacement parts	5-11
Chapter 6	After-Sales Service	6-1
6.1	Warranty	6-1
6.2	Repair parts stocking Period	6-1
6.3	When Requesting Service.....	6-1
6.4	Recommended Checks Inspection	6-1
Chapter 7	Disposal	7-1
7.1	Disposal of Equipment	7-1
7.2	Disposal of Used Batteries	7-1
Chapter 8	Specification	8-1
8.1	NWZ-1650 DISPLAY UNIT	8-1
8.1.1	Basic	8-1
8.1.2	Environment.....	8-1
8.2	JLR-4350 GPS Sensor.....	8-2
8.2.1	Basic	8-2
8.2.2	Environment.....	8-2
8.3	NDC-4100 Processor Unit.....	8-3
8.3.1	Basic	8-3
8.3.2	Environment.....	8-3
8.3.3	Interface	8-4
Appendix	1
Appendix 1	List of Geodetic System	1
Appendix 2	List of standard terms, units and abbreviations	2
Appendix 3	List of Symbols.....	7
Appendix 4	List of Default Setting Values	8
Appendix 5	Data Format	14
Appendix 6	Compass Safe Distance	32
Appendix 7	About Chinese version RoHS	33

Chapter 1 Equipment Overview

1.1 Functions

This equipment (JLR-8600) is a GPS navigator with a JLR-4350GPS sensor that is connected to the NWZ-1650 display unit and the NDC-4100 processing unit.

JLR-4350, which is a multi-GNSS receiver that is capable of receiving data from GPS as well as GLONASS or BeiDou, operates around-the-clock to measure positions with high accuracy anywhere in the world and in all weather conditions by using the GPS satellite and the GLONASS satellite, or the BeiDou satellite, and produces highly reliable positioning results. In addition, the GPS navigator can increase the accuracy of position fixing by receiving correction data from the SBAS satellites.

1.2 Features

- Registration of up to 100 routes and 10000 waypoints
- Many output ports installed with the built-in buffer unit
- Enables sharing of a route with ECDIS by the mounted LAN
- High visibility 6.5-inch large colour LCD
- Provided with many graphic display modes
- Mutual acknowledgment through a contact or ALR
- Improved operability by touch panel and abundant menus
- High reliability by the multi-GNSS receivers (GPS/GLONASS/BeiDou/QZSS/SBAS)
- Built-in RAIM function

1.3 Configuration

1.3.1 Standard Configuration

JLR-8600

No	Name	Model	Q'ty	Note
1	GPS Sensor Unit	JLR-4350	1	
1-1	Screw Adapter	MTV302007A	1	
1-2	Mounting Band	MPBP02520	1	Include 2 bands
1-3	Instruction manual	7ZPNA4693	1	English
1-4	Cable guard rubber	MPPK31468	1	
2	Processor Unit	NDC-4100	1	
2-1	Fuse	MF51NR 250V 5 MF51NR 250V 2	1	MF51NR 250V 5 :4 Fuses MF51NR 250V 2 :1 Fuses
2-2	Model Plate	MPNN52482	1	For JLR-8600-D
3	Display Unit	NWZ-1650	1	
3-1	Model Identification Plate	MPNN50903A	1	
3-2	Clamp Filter	5MBIR00009	1	
3-3	Flush mount kit	MPBX50891	1	
4	Display cable	CFQ-7540	1	LAN 15m for DISPLAY
5	Instruction manual	7ZPNA4699	1	7ZPNA4698(Japanese)/7ZPNA4699(English)

NWZ-1650

No	Name	Model	Q'ty	Note
1	Display Unit	NWZ-1650	1	Refer to JLR-8600(3~3-3)
2	Instruction manual	7ZPNA4699	1	7ZPNA4698(Japanese)/7ZPNA4699(English)

1.3.2 Option

No	Name	Model	Q'ty	Note
1	AC/DC Power supply unit	NBD-904	1	For InmarsatC AC100/220V, DC24V Input DC24V Output
2	Data Power Cable	CFQ-7539	1	8 cores 15m / For Remote Display
3	Data power Cable	CFQ-7539-5	1	8 cores 5m / For Remote Display
4	Printer	NKG-104	1	
5	Printer Paper	7ZPJD0384	1	For NKG-104
6	Extension Cable	CFQ-9000	1	Dual end/6 cores/ 15m/For Sensor
7	Extension Cable	CFQ-9002	1	Single end/6 cores/5 m
8	Junction Box	NQE-7700A	1	6 terminals
9	Pole Mounting Kit	MPBP30608	1	For NQE-7700A
10	Coaxial Cable Kit	NQD-4414	1	Outdoor NQD-4410, Indoor NQD-4411
11	Select Switch	NCZ-777	1	Manual N4 2.5G7/2 7.5BG7/2
12	Select Switch	NCZ-1537B	1	Automatic
13	Junction Box	CQD-10	1	16 terminals
14	Screw Adapter	MTV302007A	1	For Sensor
15	Mounting Band	MPBP02520	1	For Sensor
16	Output Buffer	NQA-4351	1	
17	Select Switch	NCZ-1663	1	Manual 2.5G7/2 7.5BG7/2 N2.5
18	External Dimmer unit	NCM-227	1	7.5BG7/2 2.5G7/2
19	Printer	RP-D10	1	Network printer
20	Power supply	NBG-980		Power supply unit for Network printer
21	Base kits	MPBX50347	1	

1.4 Construction

NWZ-1650 Display Unit (Desktop mount)

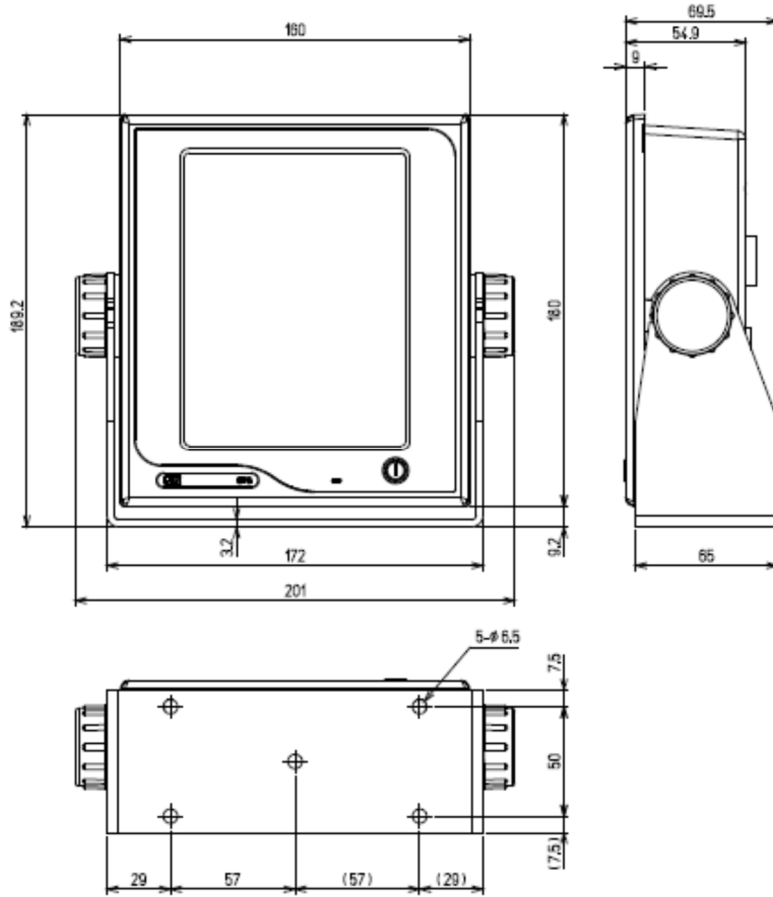

Unit: mm
Mass: Approximately 1.5kg
Color: Munsell N2.5
IP Grade: IP56

Base kits is option.

NWZ-1650 Display Unit (Flush Mount)

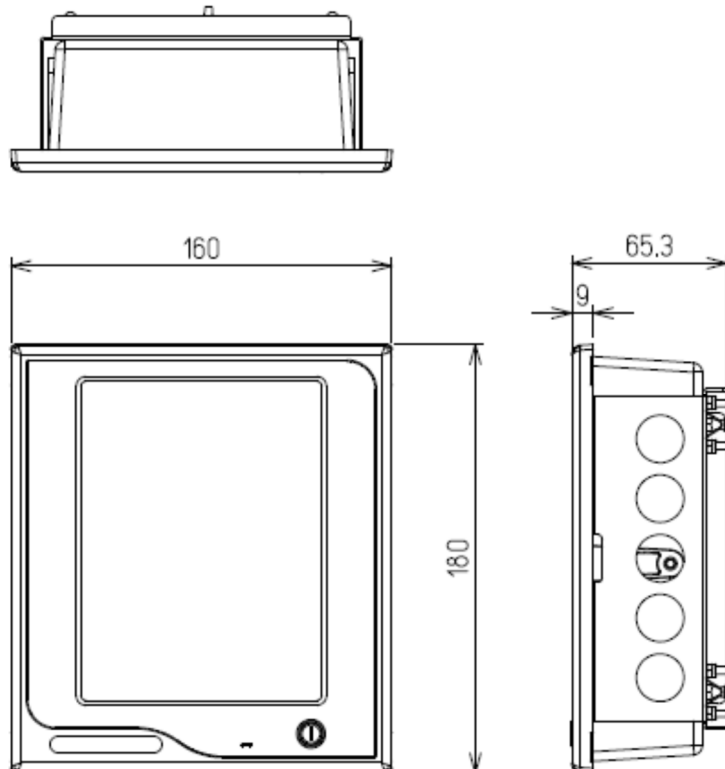

Unit: mm
Mass: Approximately: 1kg
Color: Munsell N2.5
IP Grade: IP56

NDC-4100 Processor Unit

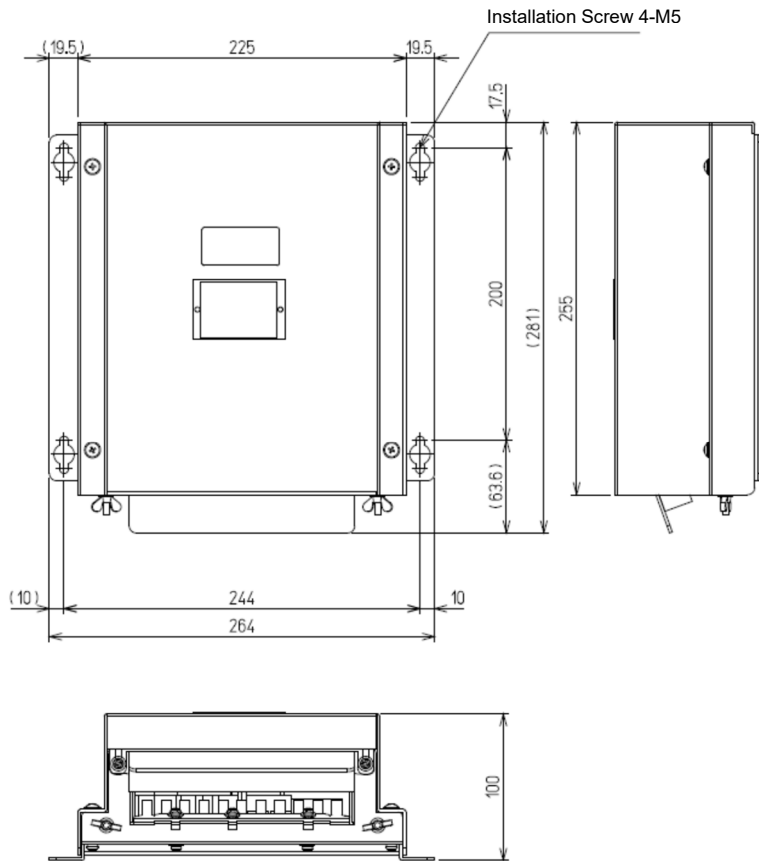

Unit: mm
 Mass: Approximately 1.9kg
 Color: Munsell N2.5
 IP Grade: IP22

JLR-4350 GPS Sensor Unit

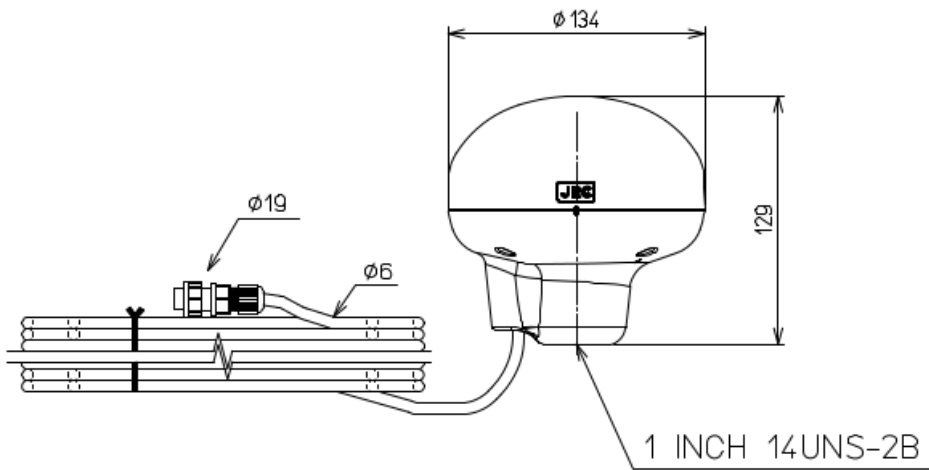

Unit: mm
 Mass: Approximately 1.2kg (include 15m cable)
 Color: Munsell N9
 IP Grade: IP56 (IEC60945)

NBD-904 AC/DC Power supply unit

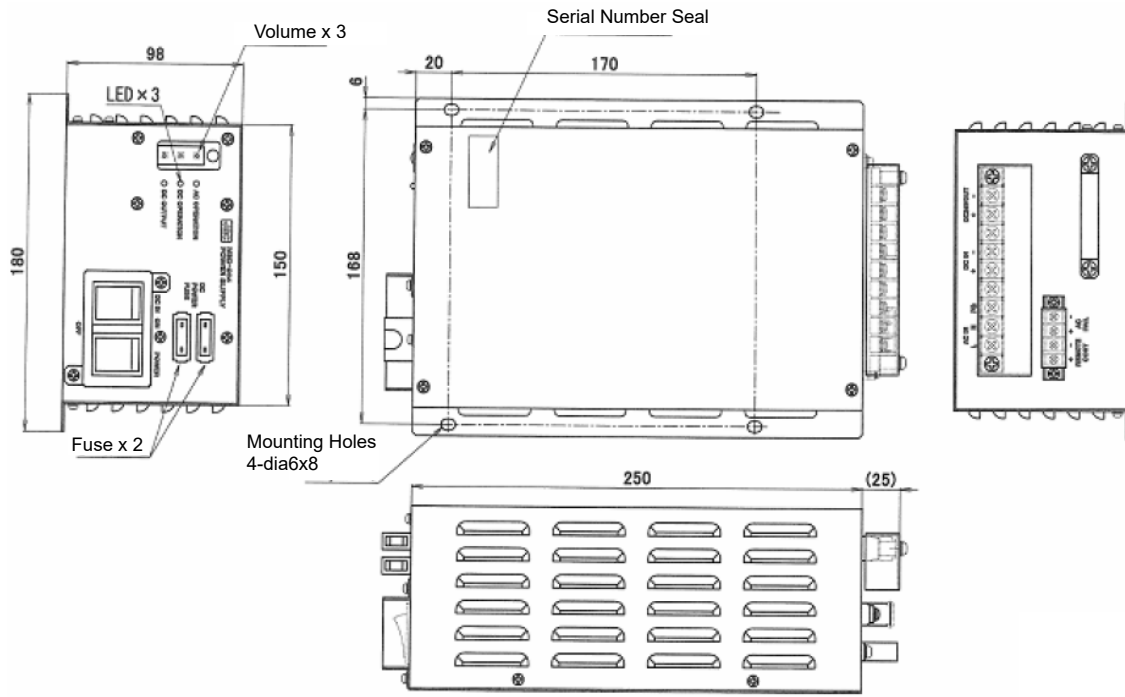

Unit: mm
 Mass : Approximately 2.6 kg

NQE-7700A Junction Box

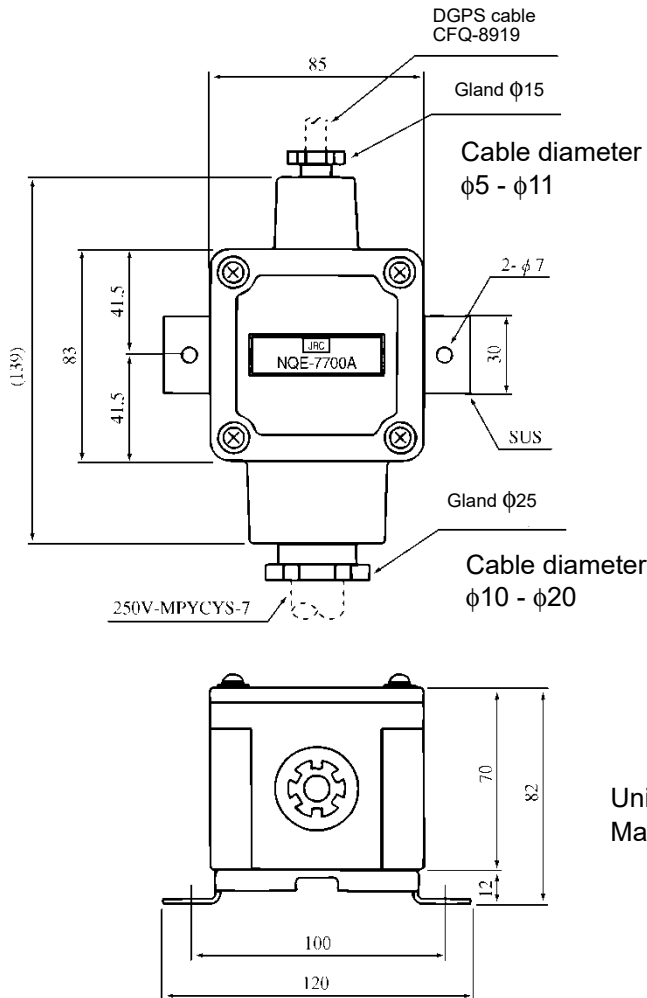

Unit: mm
 Mass: Approximately 0.6 kg

NQD-4414 Coaxial Cable Kit (outdoor use NQD-4410)

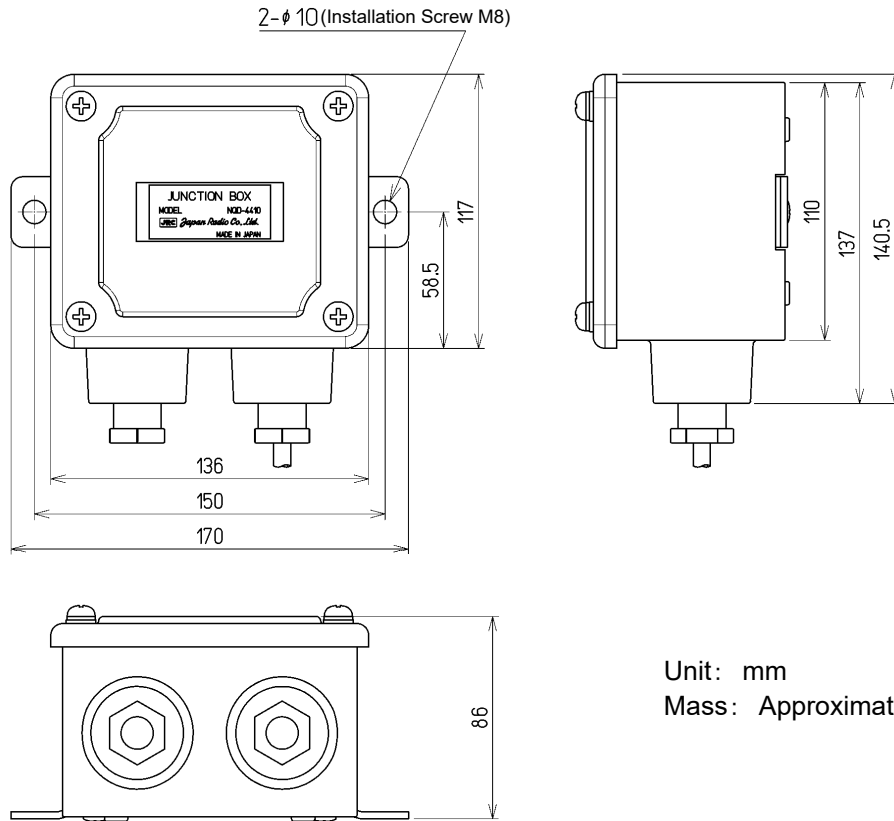

Unit: mm
 Mass: Approximately 1.5 kg

NQD-4414 Coaxial Cable Kit (indoor use NQD-4411)

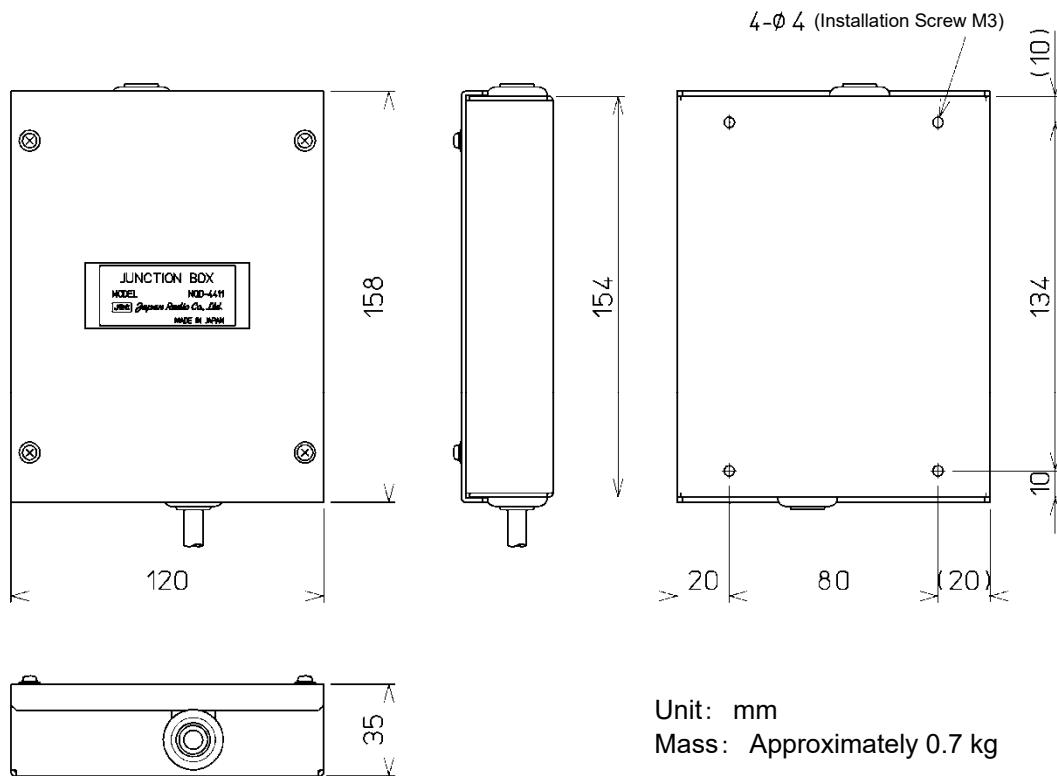

Unit: mm
 Mass: Approximately 0.7 kg

NQA-4351 Output Buffer

DC INPUT (IEC 61162-1 OR NMEA) DATA INPUT (IEC 61162-1 OR NMEA)
SELECT SIGNAL

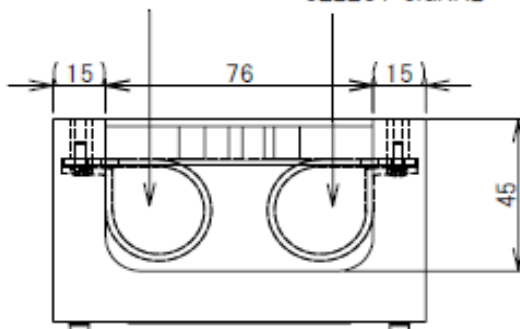

MOUNTING HOLES(2-dia7)
(INSTALLATION SCREW M6)

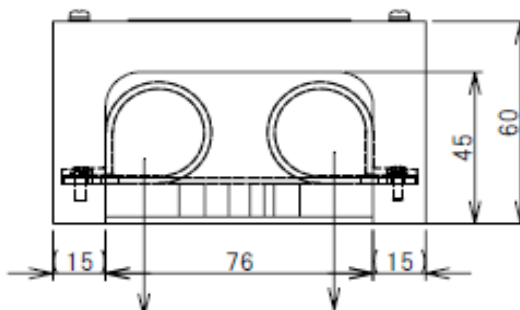
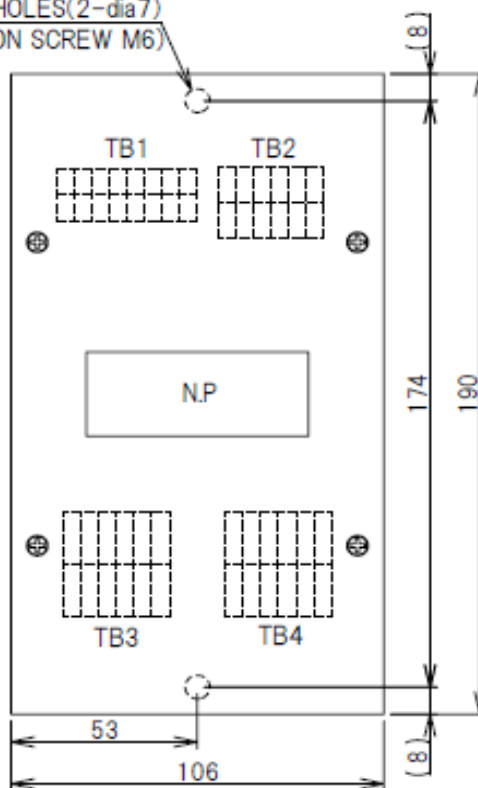

DATA OUT (IEC 61162-1 OR NMEA) DATA OUT (IEC 61162-1 OR NMEA)

Note:

JUMPER OF DC INPUT VOLTAGE			
DC input voltage	Jumper of Terminal		
DC 12V input	TB1-IN <table border="1" style="display: inline-table; vertical-align: middle;"> <tr><td>1</td></tr> <tr><td>2</td></tr> </table> JUMPER ON 9-16V Jumper cable (Cable of 0.25 - 2.5 sq)	1	2
1			
2			
DC 24V input	TB1-IN <table border="1" style="display: inline-table; vertical-align: middle;"> <tr><td>1</td></tr> <tr><td>2</td></tr> </table> JUMPER ON 9-16V Not connect	1	2
1			
2			

Unit: mm
Mass: Approximately 0.8 kg

NCZ-777 Select Switch (Stationary)

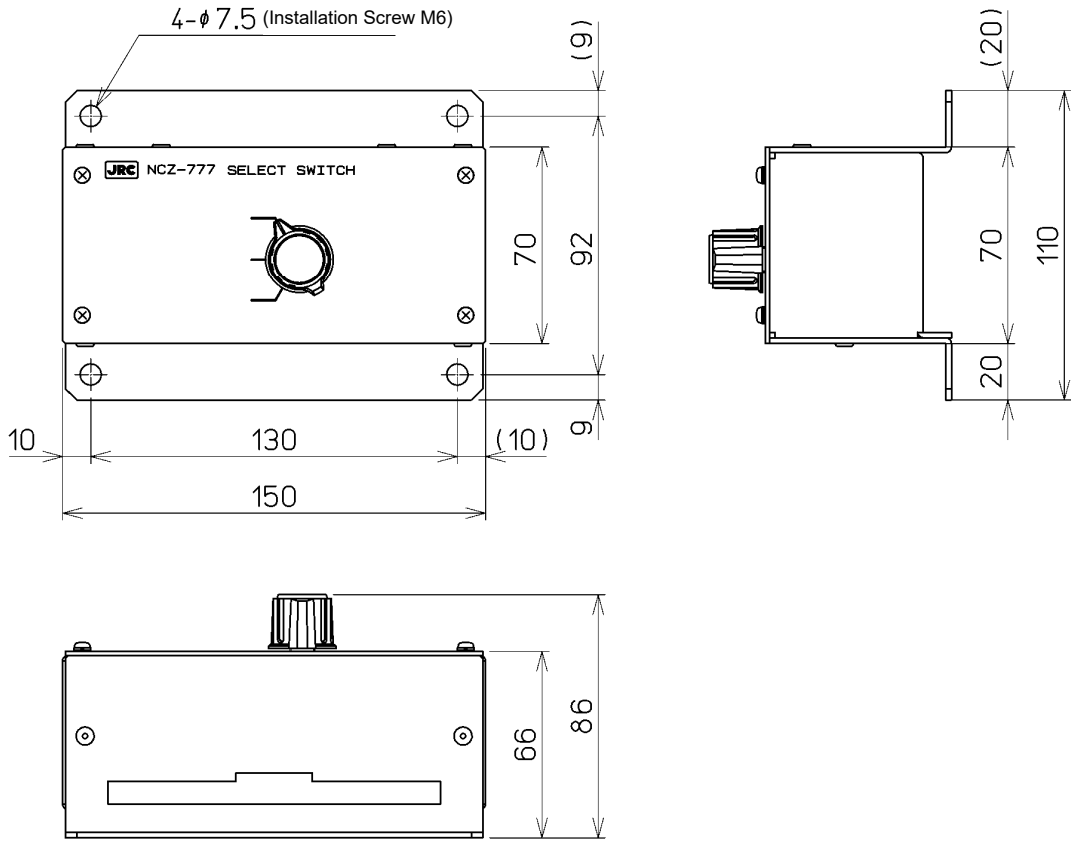

NCZ-777 Select Switch (Flush Mounting)

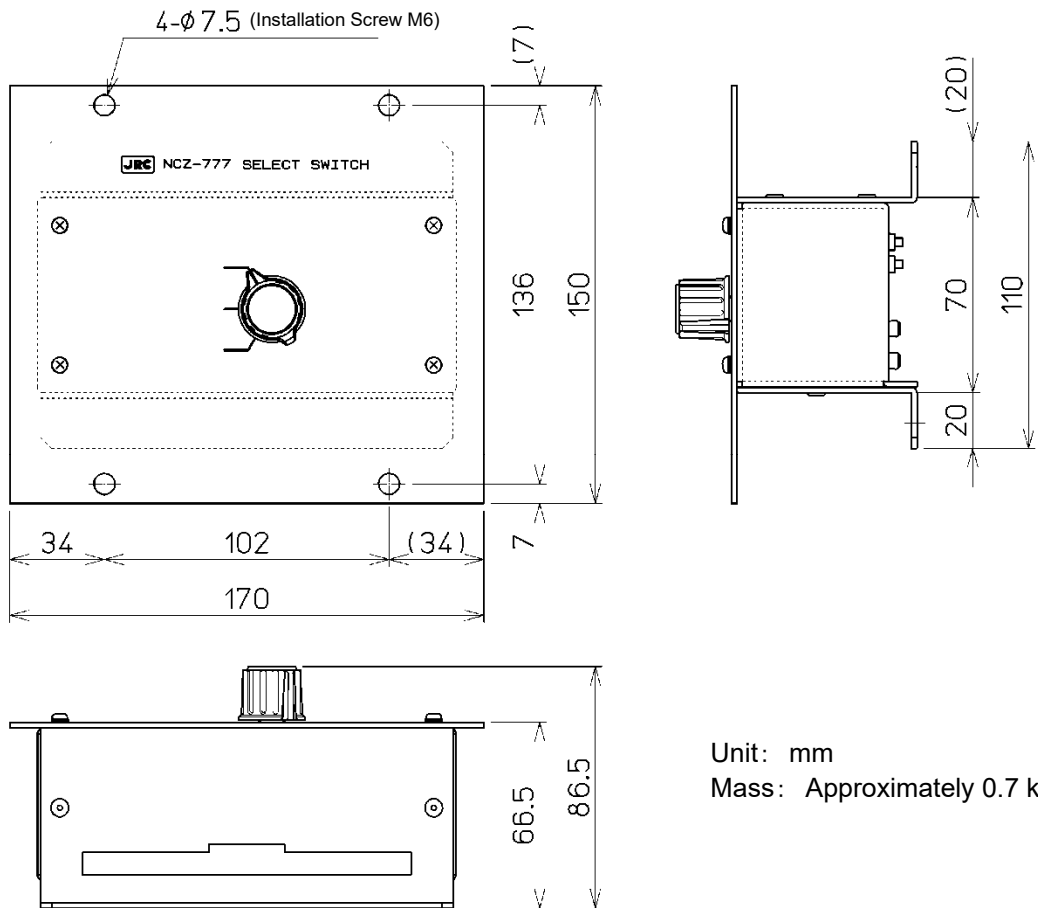

Unit: mm
 Mass: Approximately 0.7 kg

NCZ-1663 Select Switch (Stationary)

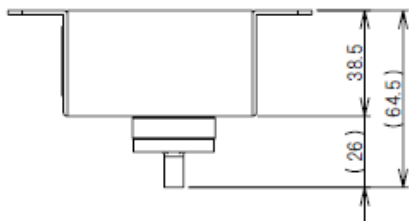

Unit: mm
 Mass: Approximately 0.2 kg

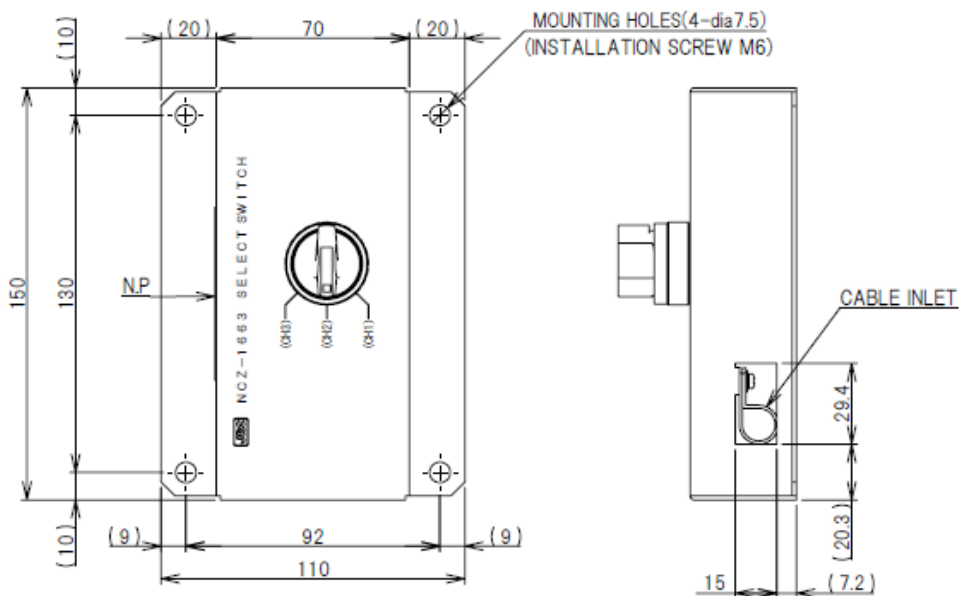

NCZ-1663 Select Switch (Flush Mounting)

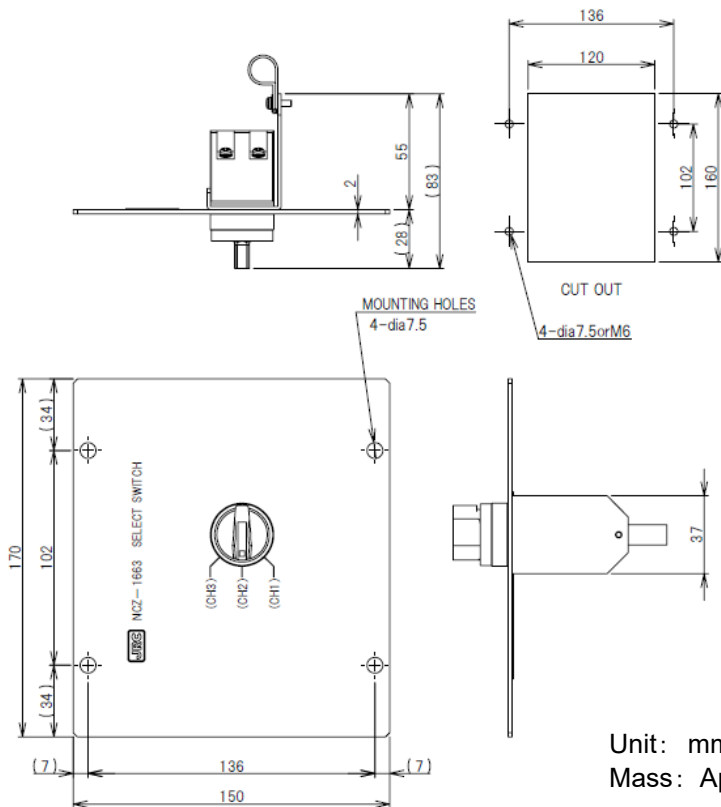

Unit: mm
 Mass: Approximately 0.2 kg

NCZ-1537B Select Switch (Flush Mounting)

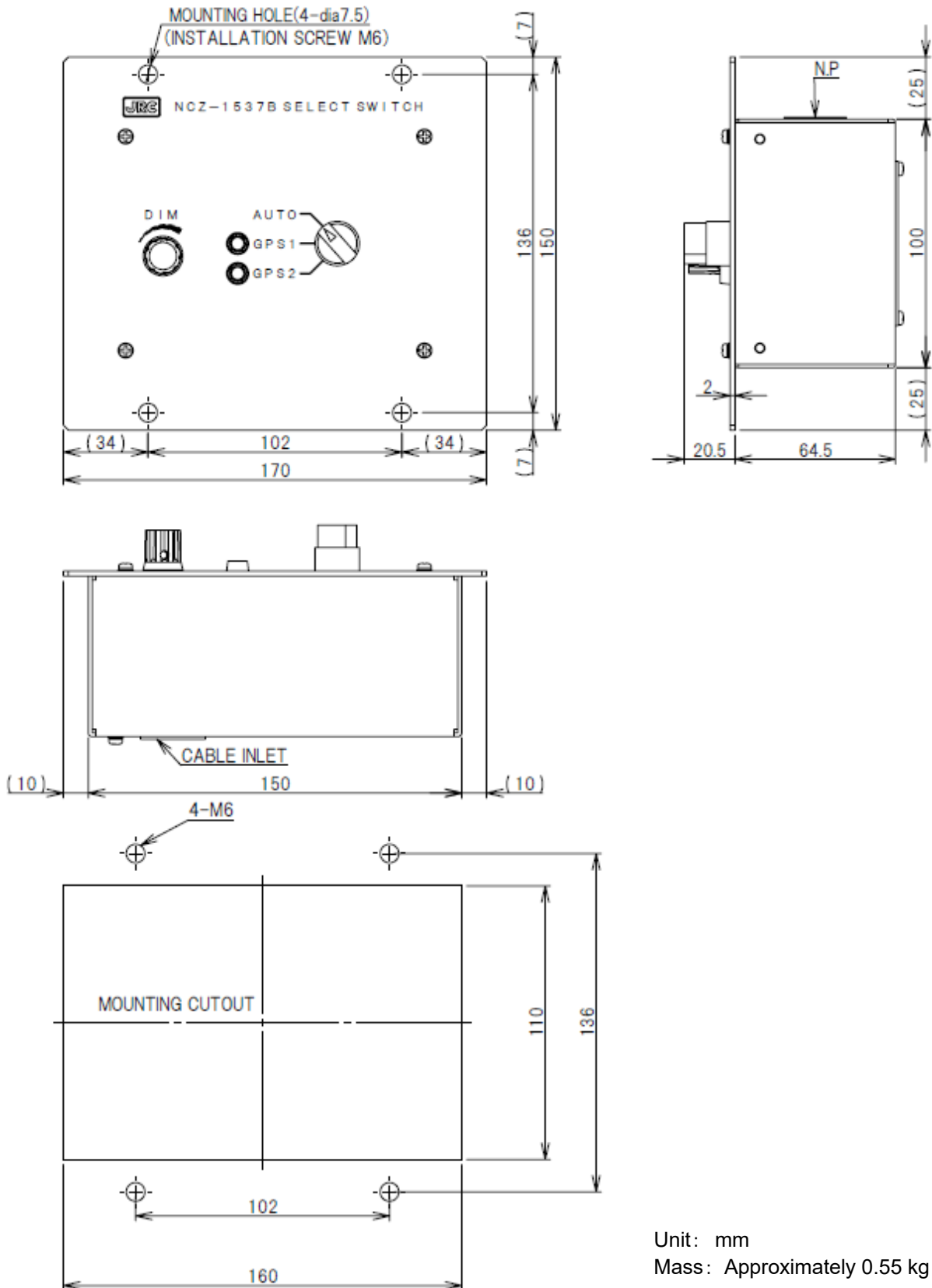

Unit: mm
 Mass: Approximately 0.55 kg

CQD-10 Junction Box

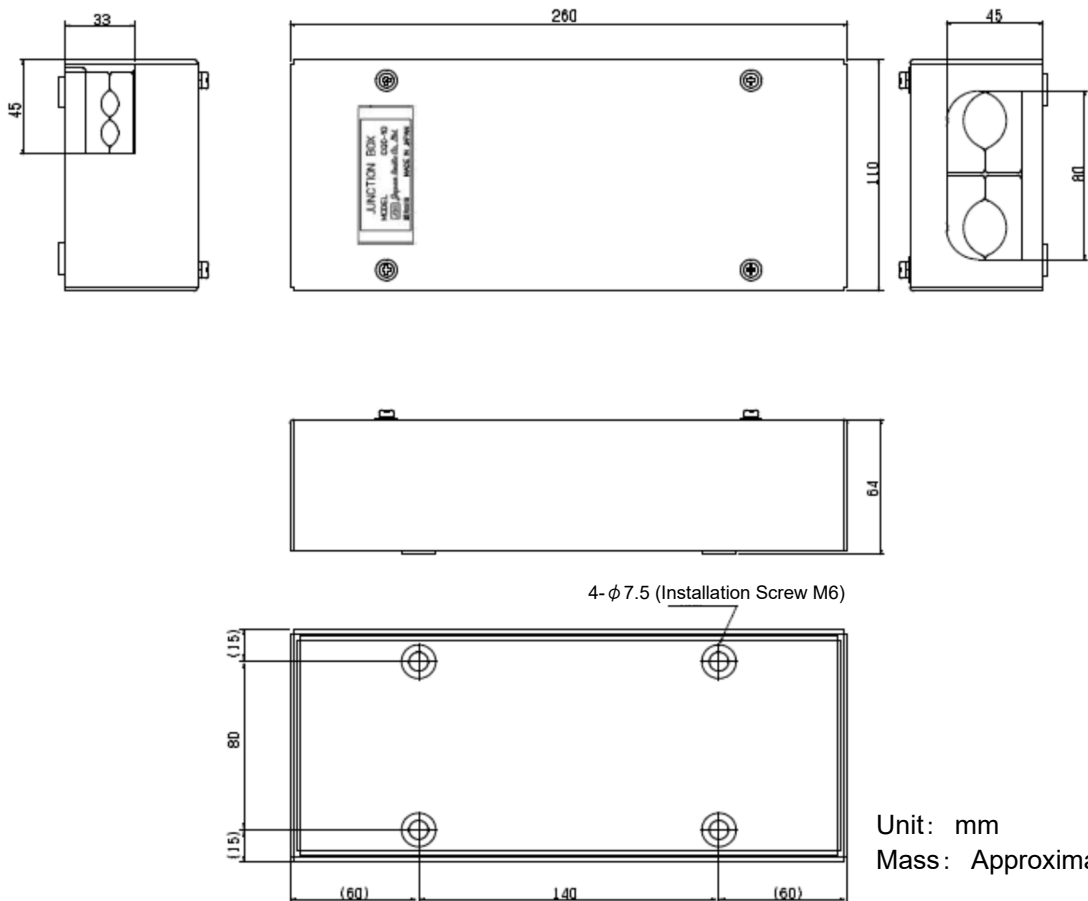

Unit: mm
Mass: Approximately 1.1 kg

NKG-104 Printer

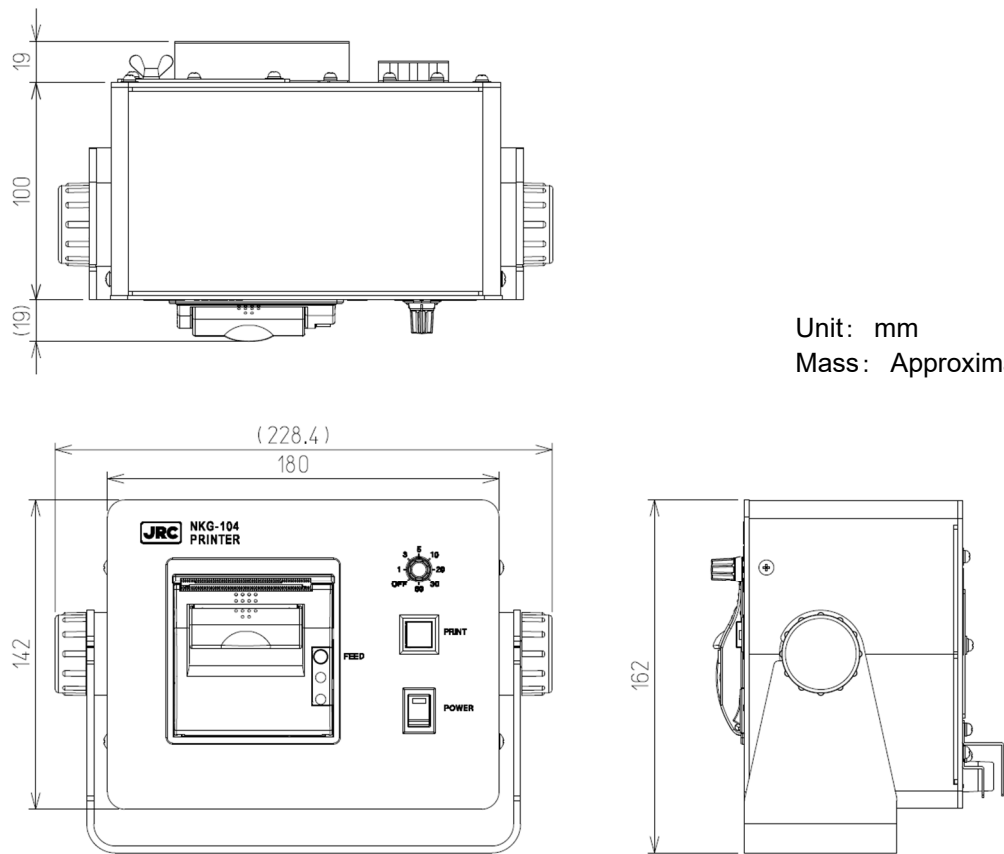

Unit: mm
Mass: Approximately 2.1 kg

1.5 System Diagram

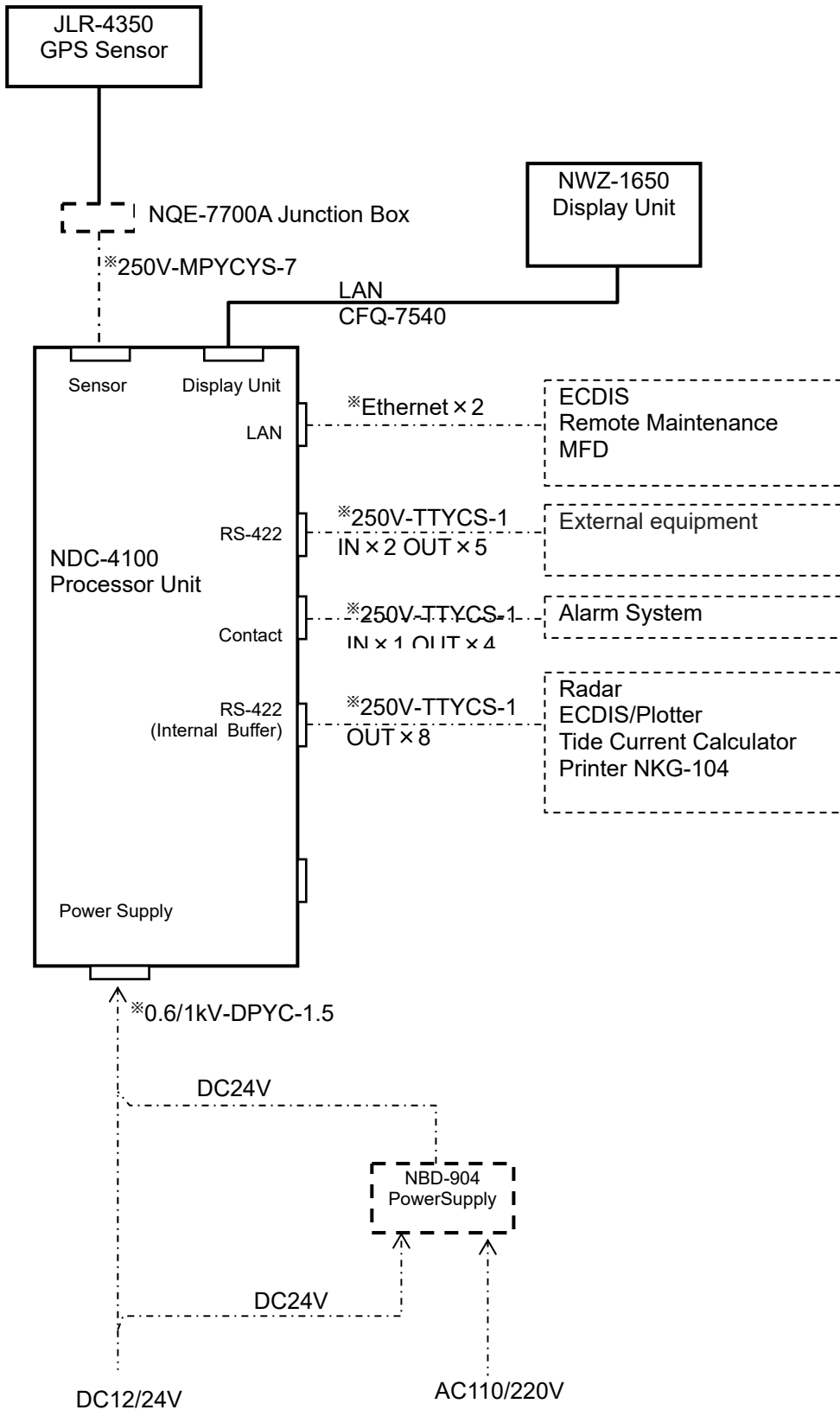

*Arranged by dockyard

Chapter 2 Name and Function of Each Unit

2.1 NWZ-1650 DISPLAY UNIT

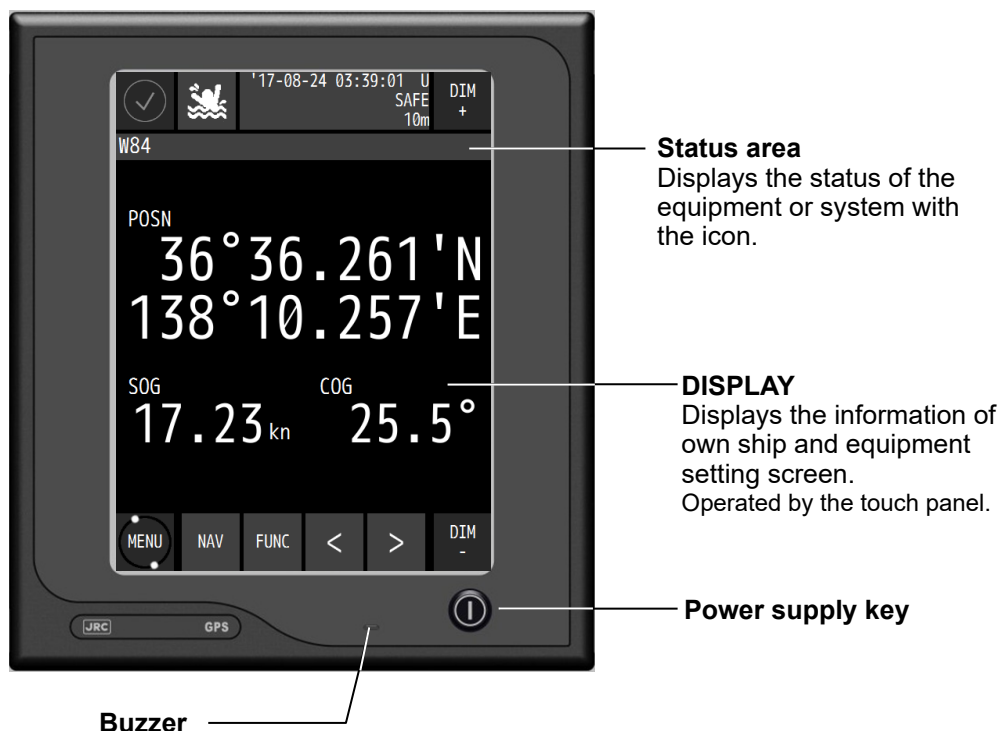

Touch panel

Key	Name	Function
	Alert	Displays the icon when an alert is issued. The icon changes according to the alert state.
	MOB	Displays a plotting screen and stores the Man OverBoard position.
	DIM UP	Increases the brightness.
	DIM DOWN	Reduces the brightness.
	Menu	Displays a menu. Displays a freeze indicator.
	Screen	Switches a main screen. Select from a main screen list.
	Function	Displays the operation menu on the main screen.
	Screen switch	Switches to a sub screen.
	Screen switch	Switches to a sub screen.

How to read the information on the display

Geodetic positioning system
W84

Status
See the status list

Date and time display (note1)
 • U: UTC
 • L: Local
 In the 12-hour display, AM/PM is displayed.

RAIM
 Displays the currently set accuracy level.
 • RAIM operating: 10m, 30m, 50m, 100m
 • RAIM OFF : OFF
 No faulty satellite: SAFE
 RAIM disabled: CAUTION
 Faulty satellite: UNSAFE

note1
 Although the displayed time may be out of sync with other display devices, it is because the data output timing is different and it is not a malfunction.

Status list

1	2	3	4	5	6	7	8	9	10	11	12	13

No	Icon	Description
1		Display unit number M: Main display unit R: Remote display unit
2		Received beacon information. Displayed when beacon information is received.
3		Magnetic correction Displayed when magnetic correction is set.
4		Waypoint update state Displays the waypoint update mode during route execution. AUTO: Automatic MAN: Manual
5		Route sharing Displayed when an Active route is shared. 1: Share 1, 2: Share 2, 3: Share 3, 4: Share 4, 5: Share 5
6		Installation mode Displayed in the installation setting mode.
7		MOB Displays when MOB is active.
8		Selected GPS for output indicates the currently selected GPS for output from built-in buffer unit.

No	Icon	Description
8		Demo mode Displayed in demo mode.
9		DGPS switched. Indicates that the mode has just changed from GPS to DGPS. This icon is cleared automatically five minutes after the switch.
10		HDOP alert Displayed when the value exceeded the setting value.
11		Sensor number using display AUTO: A sensor is selected automatically. MAN: A sensor is selected manually. EXT: External equipment number
12		Positioning system Indicates the currently set positioning system. The positioning system that is set but cannot be used is displayed in yellow. GPS: GPS GLO: GLONASS QZSS: QZSS BDS: BeiDou
13		Position fixing status GNSS: GNSS position fixing GPS: GPS position fixing DGPS: Beacon DGPS position fixing SBAS: SBAS position fixing 2D: 2 dimensional position fixing 3D: 3 dimensional position fixing No Fix: Non position fixing

2.2 JLR-4350 GPS Sensor

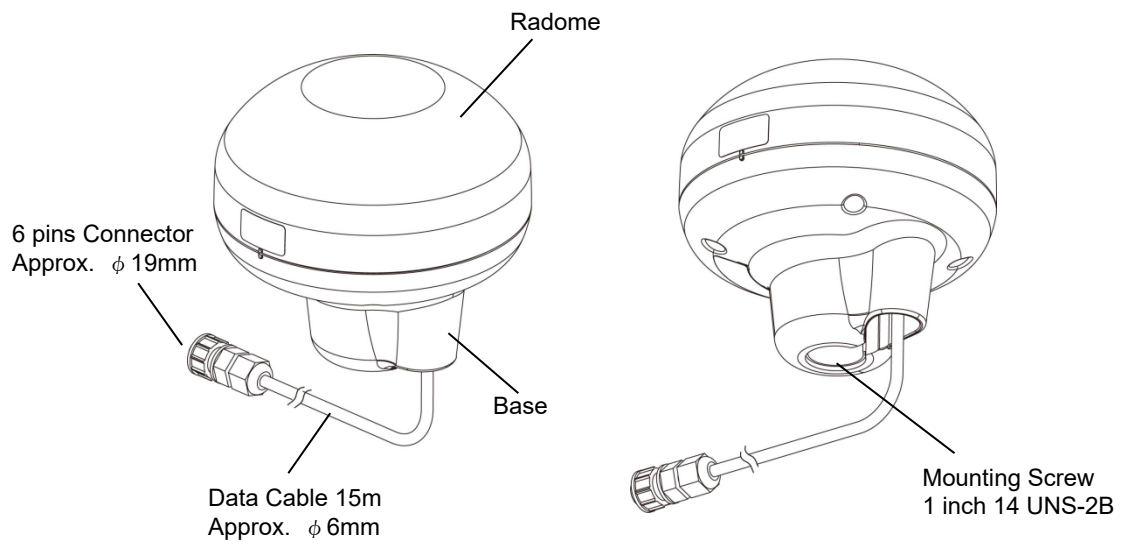

2.3 NDC-4100 Processor Unit

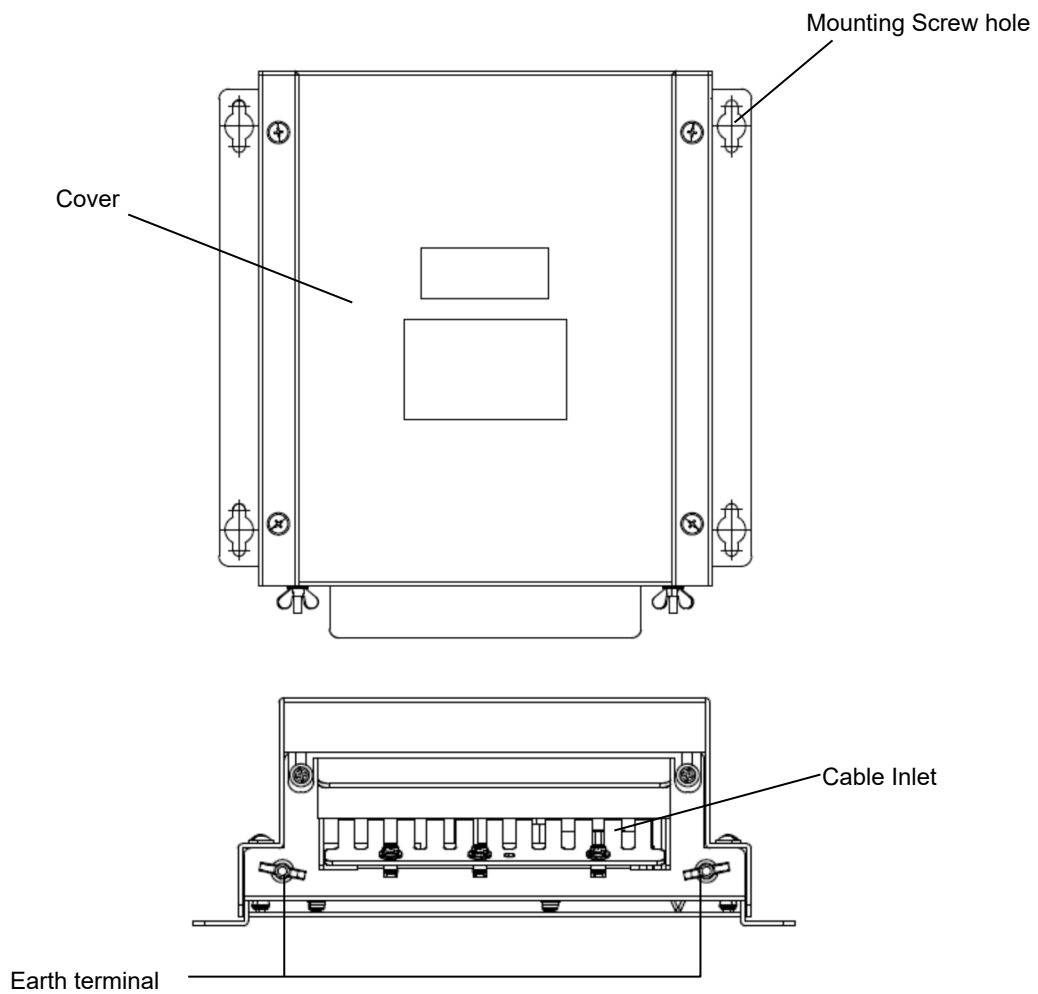

Chapter 3 Display Screens

3.1 Display Screens

3.1.1 Switching display

When the screen key **NAV** is tapped, a display screen list is displayed. Select a screen to be displayed from the list. The screen name is displayed on the screen key.

On the navigation information screen, the analogue screen, and the navigation support screen, a sub screen can be displayed by using **<** or **>**.

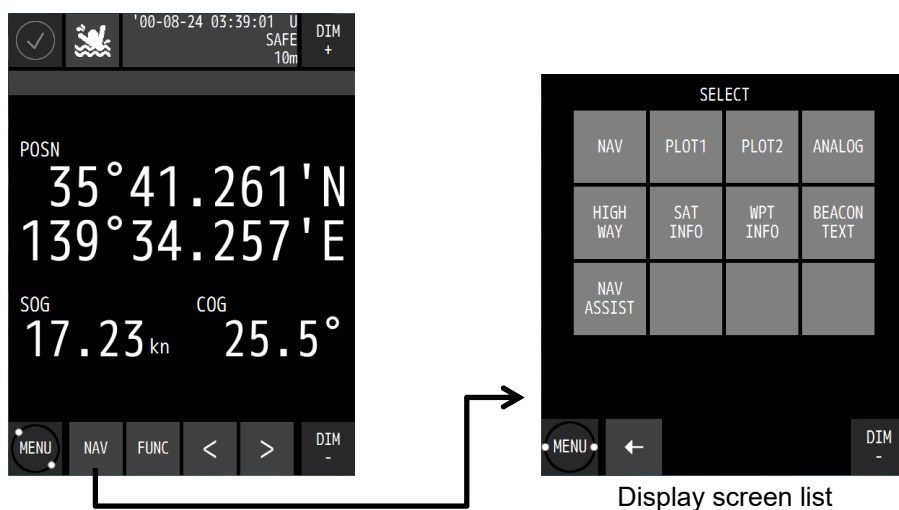

3.1.2 Navigation information screen

The navigation information screen displays the position, speed, and course of own ship. When a waypoint is available, the waypoint number and estimated time of arrival are also displayed.

A sub screen can be displayed by using **<** or **>**. The sub screen varies depending on the presence or absence of the waypoint.

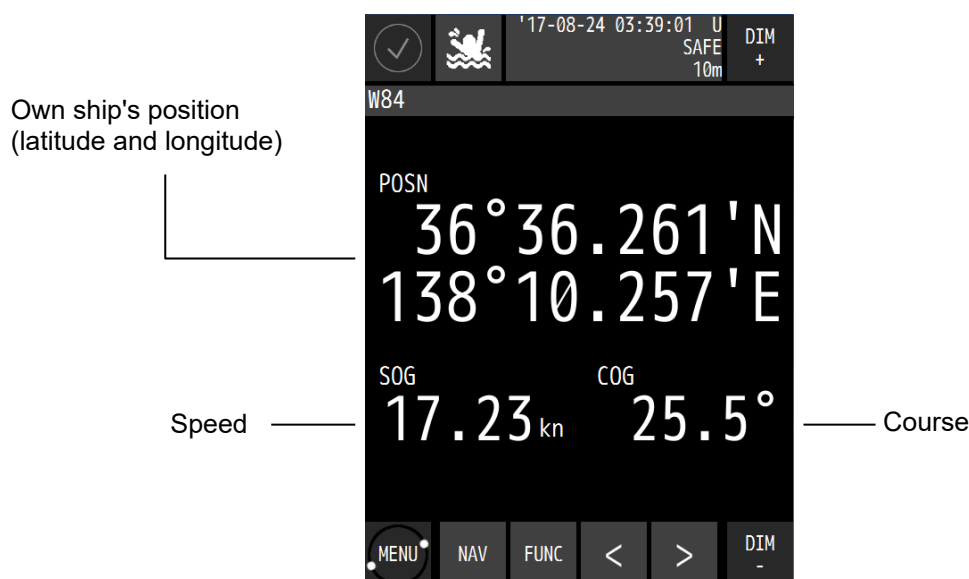

Sub screen

a) If there are no waypoints

Sub Screen 1 (4 digit position screen)

Own ship's position
(latitude and longitude)



Speed



Course

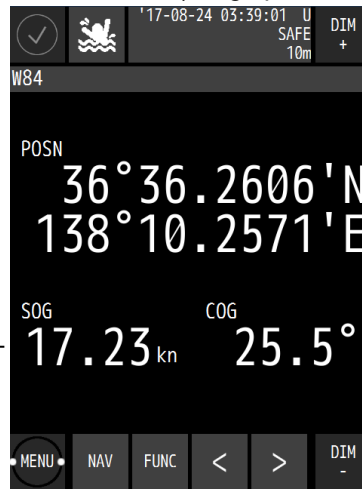

Sub Screen 2 (SOG and COG screen)

Own ship's position
(latitude and longitude)



Speed



Course

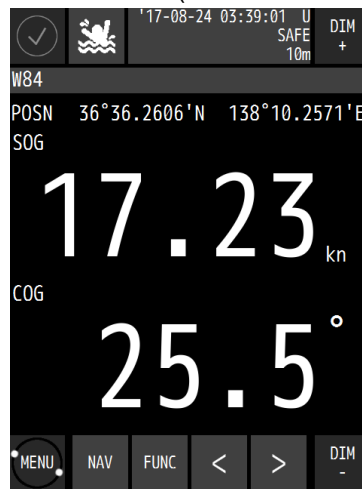

b) If there are waypoints

Sub Screen 1 (4 digit position screen)

Number of the waypoint for which the ship is heading

Speed

Distance from the own ship's position to the waypoint

Estimated arrival time at the waypoint

Route number

Own ship's position (latitude and longitude)

Course

Bearing from the own ship's position to the waypoint

Estimated arrival time at the final waypoint

Sub Screen 2 (Detail screen)

Number of the waypoint for which the ship is heading

Speed

Distance from the own ship's position to the waypoint

Speed of the destination component (See Memo.)

Deviation from the route and the steering direction
L: Steered to the left
R: Steered to the right

Own ship's position (latitude and longitude)

Course

Bearing from the present position to the waypoint

Speed of the COG component (See Memo.)

Average bearing (See Memo.)

Estimated arrival time at the waypoint

Sub Screen 3 (SOG and COG screen)

Number of the waypoint for which the ship is heading

Speed

Estimated arrival time at the waypoint

Own ship's position (latitude and longitude)

Course

Memo

VTD (Speed of the destination component)

VTD (An acronym of "Velocity Toward Destination")

This is an index that shows how fast the boat is approaching toward the destination in the unit of knot when it is navigating at a given bearing angle and speed.

VEAR (Speed of the COG component)

VEAR (An acronym of "Velocity Along Route")

This is an index that shows how fast the vessel is approaching along the planned route in the unit of knot when it is navigating at a given course and speed.

CMG (Average bearing)

CMG (An acronym of "Course Made Good")

The bearing angle to the current position when viewed from the starting point.

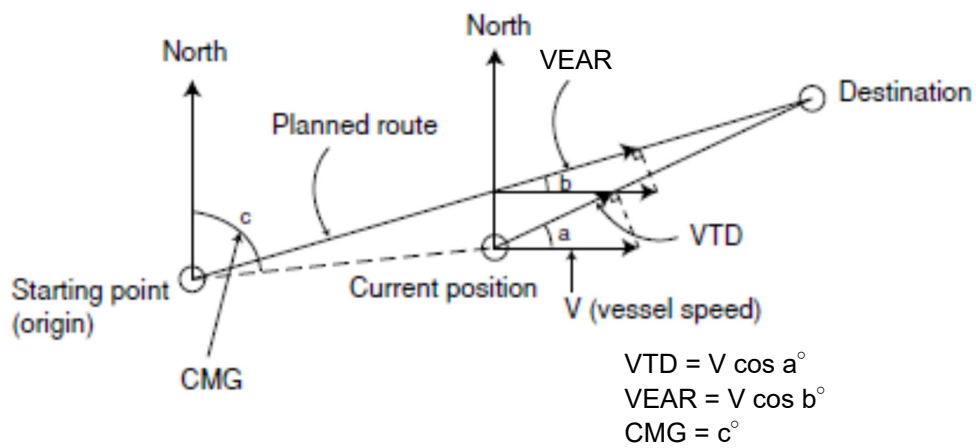

3.1.3 Plotting screen 1

⚠ CAUTION



Plotting function does not officially support navigation of SOLAS ship.

Plotting screen 1 displays the course, speed, bearing, and distance at the bottom of the screen.

The screen can be enhanced and reduced by using **ZOOM IN** and **ZOOM OUT**.

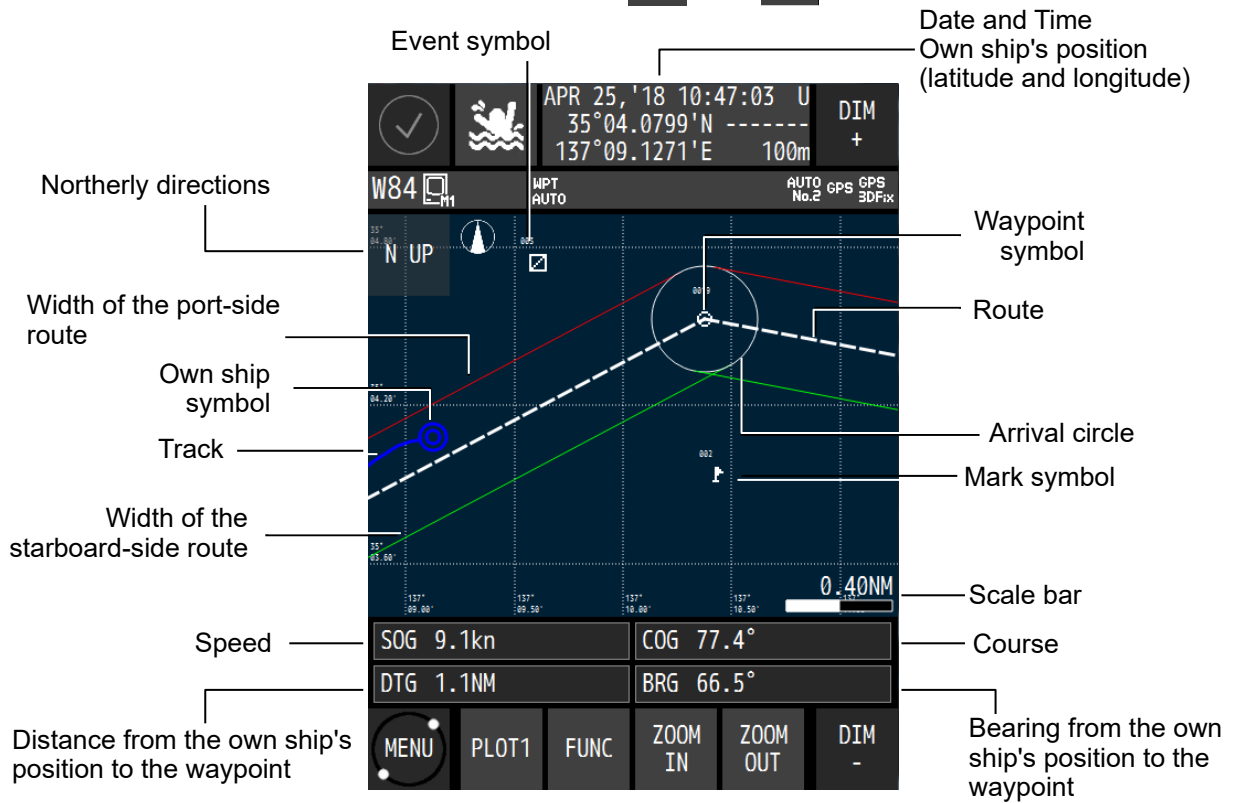

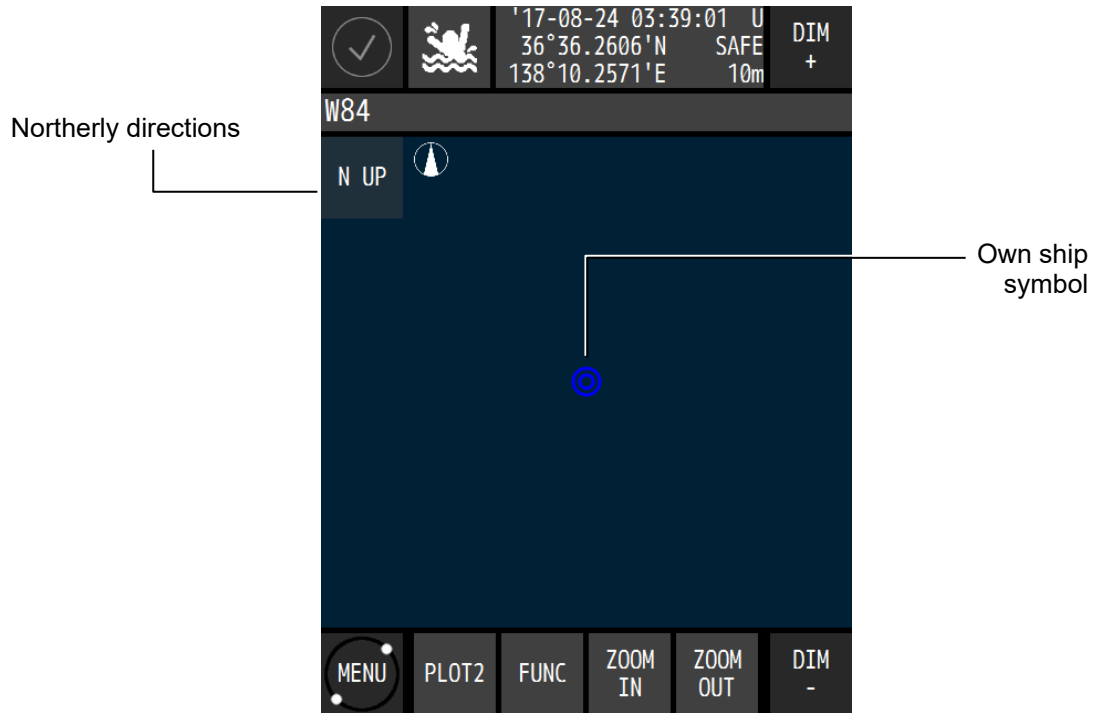

3.1.4 Plotting screen 2

Plotting screen 2 displays a plotting screen in full screen mode. The display contents and the operation are the same as for the plotting screen 1.



3.1.5 Analogue screen

The analogue screen displays the course, waypoint bearing, and CDI in graphic format. During route execution, the screen displays the off-course and distance to the waypoint.

The ship speed meter can be displayed by using  or .

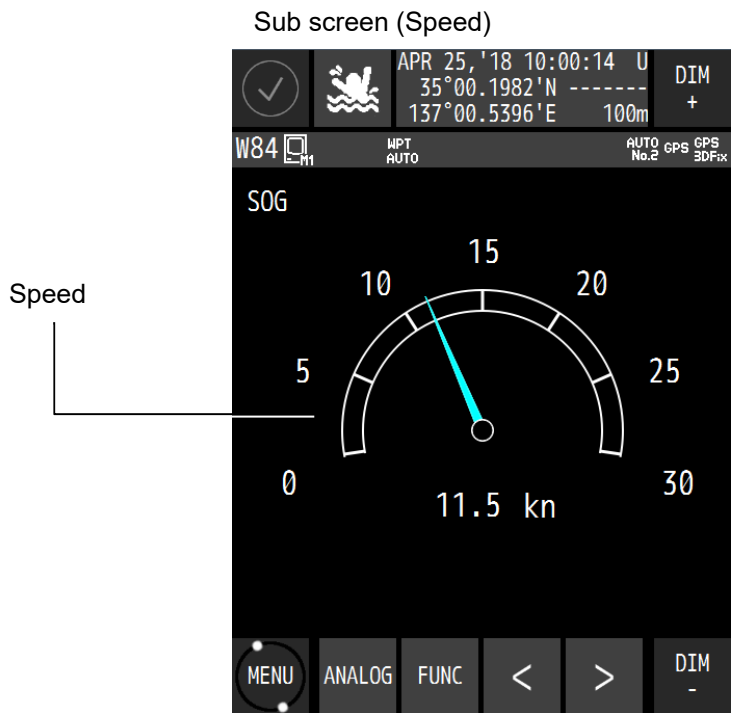
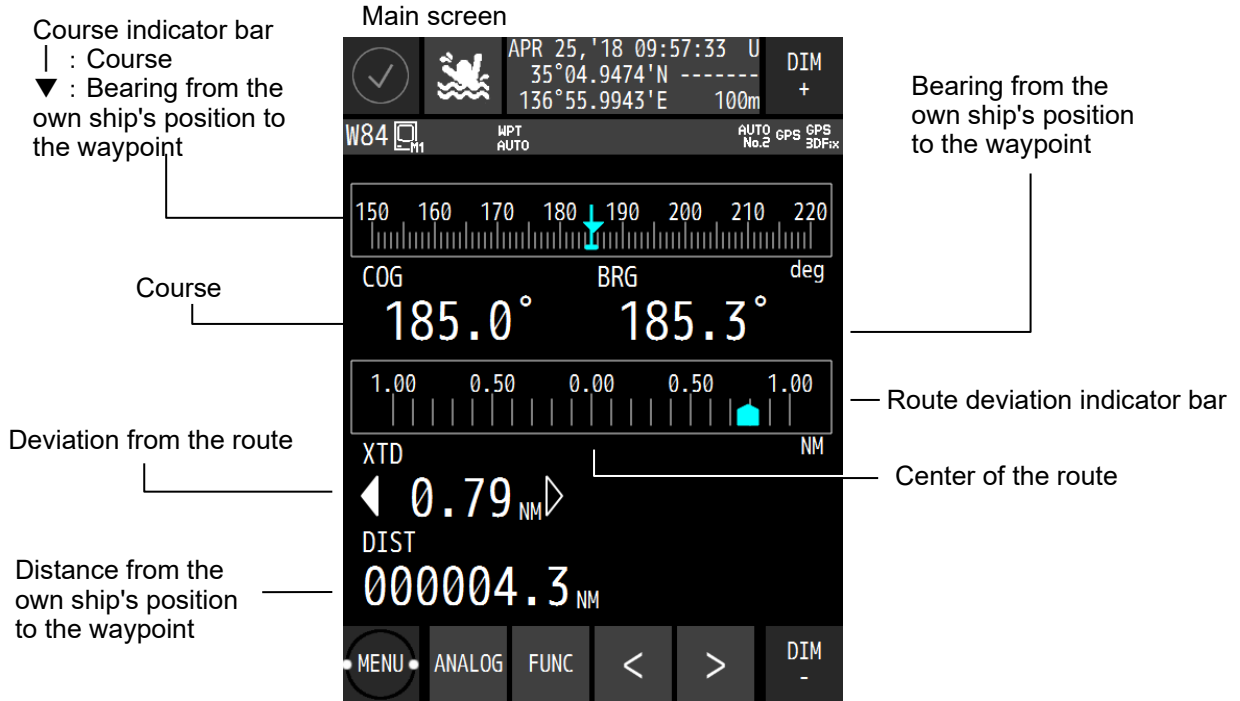

3.1.6 Highway screen

The highway screen displays the CDI, course, speed, bearing, and distance.

The highway screen displays information in Course Up mode while the own ship's position is fixed, so the route turns when the own ship turns. As a result, the route may not be displayed depending on the course.

The screen can be enhanced or reduced by using **ZOOM IN** and **ZOOM OUT** respectively.

Deviation from the route and the steering direction
 ◀: Steered to the left
 ▶: Steered to the right

Waypoint direction

Waypoint

Width of the starboard-side route

Scale bar

Course

Bearing from the own ship's position to the waypoint

Next waypoint

Route

Width of the port-side route

Speed

Own ship

Distance from the own ship's position to the waypoint

W84

NOV 25, '18 13:29:39 U

35°09.9305'N SAFE DIM +

136°53.2540'E 100m

WPT AUTO

AUTO No.2 GPS 3DFix

XTD ◀ 0.20NM ▶

4.00NM

SOG 10.0kn COG 180.0°

DTG 10.6NM BRG 174.0°

MENU HIGH WAY FUNC ZOOM IN ZOOM OUT DIM -

3.1.7 Satellite information screen

The satellite information screen displays the GNSS satellite and the beacon reception state.

The GNSS system can be switched by using **<** or **>**.

GNSS satellite location and the receiving status
 ○: Completion of demodulation
 ●: Use of position fixing
 Unframed: Search

GNSS signal intensity bar
 45 to 55 under normal conditions

Beacon frequency

Beacon SNR

Beacon error rate

GNSS HDOP

Antenna height

GNSS satellite number
 Unframed: Search
 □ : Completion of demodulation
 ■ : Use of position fixing

Beacon signal intensity

Beacon bit rate

W84

GPS

17-08-24 03:39:01 U

36°36.260'N SAFE DIM +

138°10.257'E 10m

BEACON 319.0kHz

31dB 200bps 30

WER 0.0%



HDOP 1.0

ANTENNA +21m

MENU SAT INFO FUNC DIM -

3.1.8 Waypoint information screen

The waypoint information screen displays waypoint information on the route.

The information can be switched to the next waypoint information by using  or .

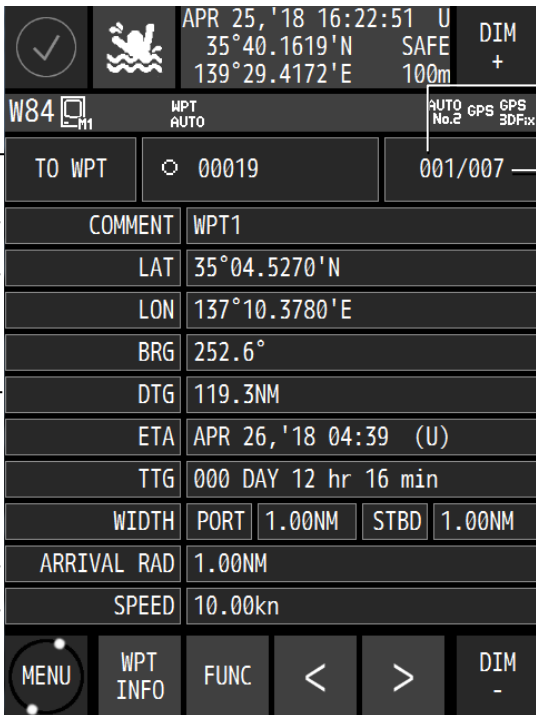

The screenshot shows the following fields and labels:

- Waypoint number:** W84
- n-th waypoint:** 001/007
- Total number of waypoints:** 001/007
- Comment on the waypoint:** WPT1
- Waypoint position:**
 - LAT: 35°04.5270'N
 - LON: 137°10.3780'E
- Bearing from the own ship's position to the displayed waypoint:** BRG: 252.6°
- Distance from the own ship's position to the displayed waypoint:** DTG: 119.3NM
- Expected arrival time at the displayed waypoint:** ETA: APR 26, '18 04:39 (U)
- Time required for reaching the displayed waypoint:** TTG: 000 DAY 12 hr 16 min
- Width of the port and starboard-side route:** WIDTH: PORT 1.00NM, STBD 1.00NM
- Arrival-circle radius:** ARRIVAL RAD: 1.00NM
- Planned ship speed:** SPEED: 10.00kn

Navigation buttons at the bottom include MENU, WPT INFO, FUNC, left arrow, right arrow, and DIM -.

3.1.9 Beacon text screen

The beacon text screen displays the beacon text information (Type 16) that is received by the beacon receiver.

Beacon text information can be deleted (FUNK → BEACON DELETE) .

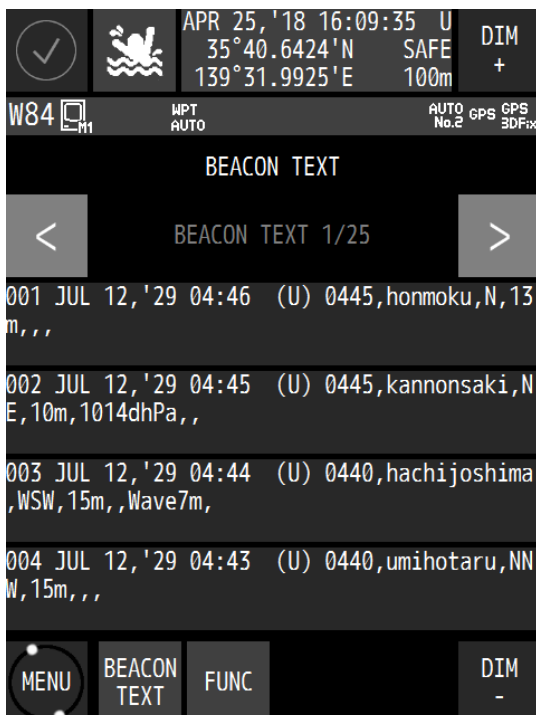

The screenshot shows the following elements:

- Previous page:** Left arrow button
- Next page:** Right arrow button
- Beacon information:** A list of messages:
 - 001 JUL 12, '29 04:46 (U) 0445,honmoku,N,13m,, ,
 - 002 JUL 12, '29 04:45 (U) 0445,kannonsaki,N E,10m,1014dhPa,,
 - 003 JUL 12, '29 04:44 (U) 0440,hachijoshima,WSW,15m,,Wave7m,
 - 004 JUL 12, '29 04:43 (U) 0440,umihotaru,NNW,15m,, ,
- Navigation buttons:** MENU, BEACON TEXT, FUNC, DIM -

3.1.10 Navigation aid screen

The navigation aid screen calculates and displays navigation information including a 4-split screen, navigation measurement, trip distance, external equipment information, and distance between two points.

The screen can be switched by using  or .

Navigation assistance screen 1

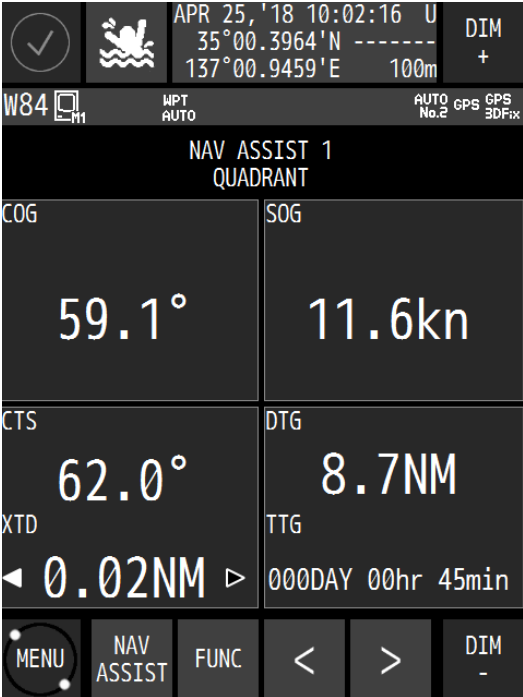

Labels for Navigation assistance screen 1:

- Course: 59.1°
- Speed: 11.6kn
- CTS: 62.0°
- DTG: 8.7NM
- XTD: 0.02NM
- TTG: 000DAY 00hr 45min
- Deviation from the route: 0.02NM

Navigation assistance screen 1 displays the following information:

- Top status bar: Checkmark, Crab icon, APR 25, '18 10:02:16 U, DIM +, 35°00.3964'N, 137°00.9459'E, 100m
- Second status bar: W84, MPT AUTO, AUTO No.2, GPS, GPS 3DFix
- NAV ASSIST 1 QUADRANT
- COG: 59.1°
- SOG: 11.6kn
- CTS: 62.0°
- DTG: 8.7NM
- XTD: 0.02NM
- TTG: 000DAY 00hr 45min
- Bottom bar: MENU, NAV ASSIST, FUNC, <, >, DIM -

Navigation assistance screen 2 (measurement for navigation)

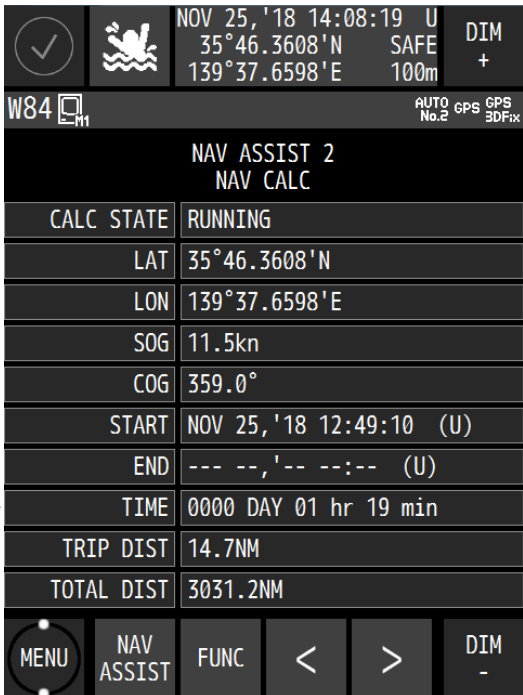

Labels for Navigation assistance screen 2:

- Own ship position: LAT 35°46.3608'N, LON 139°37.6598'E
- Speed: SOG 11.5kn
- Course: COG 359.0°
- measurement start time: START NOV 25, '18 12:49:10 (U)
- measurement end time: END --- --, '--- --:-- (U)
- Total time: TIME 0000 DAY 01 hr 19 min
- Trip: TRIP DIST 14.7NM
- Total distance: TOTAL DIST 3031.2NM

Navigation assistance screen 2 displays the following information:

- Top status bar: Checkmark, Crab icon, NOV 25, '18 14:08:19 U, DIM +, 35°46.3608'N, 139°37.6598'E, 100m
- Second status bar: W84, MPT AUTO, AUTO No.2, GPS, GPS 3DFix
- NAV ASSIST 2 NAV CALC
- CALC STATE: RUNNING
- LAT: 35°46.3608'N
- LON: 139°37.6598'E
- SOG: 11.5kn
- COG: 359.0°
- START: NOV 25, '18 12:49:10 (U)
- END: --- --, '--- --:-- (U)
- TIME: 0000 DAY 01 hr 19 min
- TRIP DIST: 14.7NM
- TOTAL DIST: 3031.2NM
- Bottom bar: MENU, NAV ASSIST, FUNC, <, >, DIM -

Labels on the right side of the screen:

- RUNNING: Measurement in progress
- END: Measurement complete

Navigation assistance screen 3 (measurement for Trip)

Navigation assistance screen 3 displays trip measurement data. The top status bar shows a checkmark, a boat icon, the date and time (NOV 25, '18 15:42:46), coordinates (35°47.3083'N, 139°37.5223'E), and other indicators like 'SAFE', '100m', and 'DIM +'. The screen title is 'NAV ASSIST 3 TRIP CALC'. It shows two trip entries:

- TRIP1:** START NOV 25, '18 12:48:52 (U), END NOV 25, '18 13:28:12 (U), TIME 0000 DAY 00 hr 39 min, AVG SPD 12.4kn, TRIP 8.1NM.
- TRIP2:** START NOV 25, '18 12:48:56 (U), END --- --, '--- --:-- (U), TIME 0000 DAY 02 hr 53 min, AVG SPD 10.5kn, TRIP 30.4NM.

Labels on the left side point to: measurement start time, Total time, Average speed, measurement start time, measurement end time, Total time, and Average speed. Labels on the right side point to: RUNNING: Measurement in progress, END: Measurement complete, measurement end time, trip, RUNNING: Measurement in progress, END: Measurement complete, and trip.

Navigation assistance screen 4 (External equipment screen)

Navigation assistance screen 4 displays external equipment data. The top status bar shows a checkmark, a boat icon, the date and time (APR 25, '18 10:09:04), coordinates (35°01.0043'N, 137°02.1858'E), and other indicators like 'SAFE', '100m', and 'DIM +'. The screen title is 'NAV ASSIST 4 EXT EQUIP'. It shows:

- STW:** 9.9kn (with up/down arrows)
- DPTH:** 253.0m
- TEMP:** +15.0°C
- CURRENT:** A table with columns DIR, SPD, and DEPTH.

	DIR	SPD	DEPTH
Layer A	125.7°	3.3kn	51.0m
Layer B	132.2°	2.8kn	102.0m
Layer C	128.4°	2.6kn	155.0m
Layer D	130.7°	2.3kn	178.0m
Layer E	131.2°	2.1kn	200.0m

Labels on the left side point to: Forward/backward speed through water (▲:Forward, ▼:Backward), Water depth, and Current direction, speed and depth. Layer A, Layer B, Layer C, Layer D, Layer E. Labels on the right side point to: Baw speed through water (◀ Leftward, ▶ Rightward), Stern speed through water (◀ Leftward, ▶ Rightward), and Water temperature.

Navigation assistance screen 5 (Calculation of a distance/bearing between two points)

Navigation assistance screen 5 displays distance and bearing calculation data. The top status bar shows a checkmark, a boat icon, the date and time (NOV 25, '18 13:38:45), coordinates (35°42.7031'N, 139°35.1115'E), and other indicators like 'SAFE', '100m', and 'DIM +'. The screen title is 'NAV ASSIST 5 DIST CALC'. It shows:

- STARTING POINT:** LAT 35°42.5563'N, LON 139°34.9947'E
- TERMINAL POINT:** LAT 35°36.5422'N, LON 138°08.1036'E
- SAIL:** RL
- DIST:** 71.17NM
- BRG:** 265.1°

Labels on the left side point to: Starting point (Latitude and longitude), Distance, and Bearing. Labels on the right side point to: Terminal point (Latitude and longitude), Distance calculation method (GC: Great circle sailing, RL: Rhumb line sailing).

Chapter 4 Operation

4.1 Menu List

4.1.1 Main Menu

MENU	Sub Menu	Sub Menu	Sub Menu	Range	Reference	
DISPLAY	THEME			DAY/DUSK/NIGHT	4.3.1	
	BEEP			OFF / ON	4.3.2	
	DAY SCREEN			OFF / ON	4.3.3	
	NAV			OFF / ON	4.3.4	
	PLOT			OFF / ON	4.3.4	
	ANALOG			OFF / ON	4.3.4	
	HIGHWAY			OFF / ON	4.3.4	
	SAT INFO			OFF / ON	4.3.4	
	WPT INFO			OFF / ON	4.3.4	
	BEACON TEXT			OFF / ON	4.3.4	
NAV ASSIST			OFF / ON	4.3.4		
VOYAGE	WPT	WPT LIST			4.4.1	
	ROUTE	ROUTE LIST			4.5.1	
	RUN				4.6.1	
	EVENTMARK	EVENTMARK LIST			4.7.1	
	WPT COPY				4.4.4	
	ROUTE COPY				4.5.4	
	WPT DELETE				4.4.5	
	ROUTE DELETE				4.5.5	
	EVENT DELETE				4.7.5	
	SHARED	ROUTE SEND				4.5.6
		ROUTE RECEIVE	SOURCE IP			4.5.6
	DEFAULT SETTINGS	WIDTH PORT(NM)			0.00~9.99	4.5.7
		WIDTH STBD(NM)			0.00~9.99	4.5.7
		ARRIVAL RADIUS(NM)			0.00~9.99	4.5.7
		SPEED(kn)			00.00~99.99	4.5.7
SAIL				GC/RL	4.5.7	
SOG SMOOTHING(s)				0~99	4.5.7	
ALERT	SYSTEM	SET		OFF / ON	4.10.1	
		SOUND		OFF / ON	4.10.1	
	ARRIVAL/ ANCHOR	SET		OFF / ARRIVAL / ANCHOR	4.10.1	
		SOUND		OFF / ON	4.10.1	
	XTD/ BOUNDARY	SET		OFF / XTD / BOUNDARY	4.10.1	
		SOUND		OFF / ON	4.10.1	
	HDOP	SET			4.10.1	
		SOUND		OFF / ON	4.10.1	
	SPD	SET			4.10.1	
		SOUND		OFF / ON	4.10.1	
	TRIP	SET			4.10.1	
		SOUND		OFF / ON	4.10.1	
	EARLY COURSE CHANGE	SET			4.10.1	
		SOUND		OFF / ON	4.10.1	
	END OF TRACK	SET			4.10.1	
SOUND			OFF / ON	4.10.1		
ARRIVED AT WOL	SET		OFF / ON	4.10.1		
	SOUND		OFF / ON	4.10.1		

MENU	Sub Menu	Sub Menu	Sub Menu	Range	Reference	
ALERT	ACTUAL COURSE CHANGE	SET		OFF / ON	4.10.1	
		SOUND		OFF / ON	4.10.1	
	TEMP	SET			4.10.1	
		SOUND		OFF / ON	4.10.1	
	DPTH	SET			4.10.1	
		SOUND		OFF / ON	4.10.1	
	DGPS	SET		OFF GPS→DGPS DGPS→GPS GPS↔DGPS	4.10.1	
		SOUND		OFF / ON	4.10.1	
	BUFFER	SET		OFF / ON	4.10.1	
		SOUND		OFF / ON	4.10.1	
	POWER	SET		OFF / ON	4.10.1	
		SOUND		OFF / ON	4.10.1	
	ALARM ESCALATION	POSITION		OFF / ON	4.10.3	
		HEADING		OFF / ON	4.10.3	
		TIME(s)		30/ 60/ 120/ 180/ 240/ 300	4.10.3	
	HEADET ALERT	GROUPING		OFF / ON	4.10.3	
		AGGREGATION		OFF / ON	4.10.3	
TEST MODE			OFF / ON	4.10.3		
GNSS SETTING	SENSOR1	GNSS	GPS MODE	GPS	4.12.1	
		FIX MODE		2D / 3D / AUTO	4.12.2	
		ELV MASK		5~89 deg	4.12.3	
		HDOP		4/10/20	4.12.4	
		SMOOTH	POSN SMOOTHING(s)		0~99	4.12.5
			SPEED SMOOTHING(s)		0~99	4.12.5
			COURSE SMOOTHING(s)		0~99	4.12.5
		RAIM	RAIM ACCURACY LEVEL(m)		OFF/10/30/50/100	4.12.6
		DATUM			4.12.7	
		INIT	QUADRANT			4.12.8
			LAT			4.12.8
			LON			4.12.8
			ANT HEIGHT(m)			4.12.8
			YEAR			4.12.8
			MONTH			4.12.8
			DAY			4.12.8
			HOUR(hr)			4.12.8
		MINUTE(min)			4.12.8	
		DGPS			OFF / AUTO BEACON / SBAS	4.12.9
		BEACON	AUTO			4.12.10
			MANUAL		FREQUENCY/ BITRATE	4.12.10
			SEMI AUTO			4.12.10
			MONITOR			4.12.10
		SBAS	SAT SEARCH		AUTO / MANUAL (SBAS SETTING)	4.12.11
			TYPE0		OFF / ON	4.12.11
			RANGING		OFF / ON	4.12.11
		STN LIST				4.12.12

MENU	Sub Menu	Sub Menu	Sub Menu	Range	Reference
GNSS SETTING	SENSOR2	GNSS	GPS MODE	GPS	Same as Sensor1
		FIX MODE		2D / 3D / AUTO	
		ELV MASK		5~89 deg	
		HDOP		4/10/20	
		SMOOTH	POSN SMOOTHING(s)	0~99	
			SPEED SMOOTHING(s)	0~99	
			COURSE SMOOTHING(s)	0~99	
		RAIM	RAIM ACCURACY LEVEL(m)	OFF/10/30/50/100	
		DATUM			
		INIT	QUADRANT		
			LAT		
			LON		
			ANT HEIGHT(m)		
			YEAR		
			MONTH		
			DAY		
			HOUR(hr)		
			MINUTE(min)		
			DGPS		
		BEACON	AUTO		
			MANUAL	FREQUENCY/ BITRATE	
			SEMI AUTO		
			MONITOR		
		SBAS	SAT SEARCH	AUTO / MANUAL (SBAS SETTING)	
TYPE0	OFF / ON				
RANGING	OFF / ON				
STN LIST					
SYSTEM	DATE / TIME	TIME DIFF		+00:00~+13:30	4.13.1
		DATE DISP		'YY-MM-DD DD MMM,'YY MMM DD,'YY	4.13.1
		TIME DISP(hr)		12hr / 24hr	4.13.1
	UNIT	DIST / SPEED		NM,km km,km/h mi,mi/h	4.13.2
		HIGHT / DPTH		m / ft / fm	4.13.2
		TEMP		°C / F	4.13.2
	MAG CORR				4.13.3
	LORAN			OFF / LORAN A,C	4.13.4
	SENSOR SELECT			AUTO/ SENSOR1,2	4.13.5
	LANGUAGE			JAPANESE/ ENGLISH	4.15
VERSION	DISPLAY				4.16
	PROCESSOR				4.16
	SENSOR1				4.16
	SENSOR2				4.16
ALERT LIST	ALERT HISTORY				4.11.1
	ACTIVE ALERT				4.11.2
	LAN1				4.11.3
	LAN2				4.11.3

MENU	Sub Menu	Sub Menu	Sub Menu	Sub Menu	Range	Reference	
EQUIP	TYPE	TYPE1 / 2 DISPLAY	DISPLAY TYPE		MAIN REMOTE(LAN) REMOTE (SERIAL)	—	
			SFI		GP0000	—	
		TYPE2/2 PROCESSOR	DEVICE No.		No1.~No3.	—	
			SFI		GP0000	—	
			SENSOR1		OFF GPS COMPASS OTHER EQUIP	—	
			SENSOR2		OFF GPS COMPASS OTHER EQUIP	—	
	DATA I/O	IN/OUT1				—	
		IN/OUT2				—	
		IN/OUT3				—	
		OUT4				—	
		OUT5				—	
		OUT6				—	
		LAN	LAN1		DATA OUT		—
					RMS SEND		—
					PRINTER		—
			LAN2		DATA OUT		—
					RMS SEND		—
					PRINTER		—
			COMMON		ACTIVE ROUTE		—
					DATA ROUTE		—
					MUTUAL		—
		CONTACT1	CONTACT OUT			—	
		CONTACT2	CONTACT OUT			—	
		CONTACT3	CONTACT OUT			—	
		CONTACT4	CONTACT OUT			—	
		BUFFER	FORMAT				—
			BITRATE(bps)				—
			VERSION				—
			TALKER				—
		SENSOR	SENSOR1 PORT2(bps)		4800 / 9600 19200 / 38400		—
			SENSOR2 PORT2(bps)		4800 / 9600 19200 / 38400		—
		RS-232C	FORMAT				—
			BITRATE(bps)				—
			VERSION				—
	TALKER					—	
	SWITCH	CONTROLL METHOD			OFF MFD FIX/NOFIX FIX/NOFIX + DOP	—	
		SWITCH SELECTION			PROCESSOR No1. PROCESSOR No2.	—	

MENU	Sub Menu	Sub Menu	Sub Menu	Sub Menu	Range	Reference		
EQUIP	DIMMER	SETTINGS	DIMMER GROUP		1~10	—		
			DISPLAY		OFF/ON	—		
			NCM-227		OFF/ON	—		
			DIMMER OFFSET		-500 ~ +500			
			DDC		OFF/ON	—		
			GPS		OFF/ON	—		
			GP DDC		OFF/ON	—		
		DIMMER CAL		MIN/MAX	—			
	IP	DISPLAY		IP ADDRESS			—	
				SUBNET MASK			—	
				MAC ADDRESS			—	
				DEFAULT GATEWAY			—	
		PROCESSOR LAN 0			IP ADDRESS			—
					SUBNET MASK			—
					MAC ADDRESS			—
					DEFAULT GATEWAY			—
		PROCESSOR LAN 1			SETTING		JRC STANDARD / MANUAL / DEFAULT	—
					IP ADDRESS			—
					SUBNET MASK			—
					MAC ADDRESS			—
					DEFAULT GATEWAY			—
		PROCESSOR LAN 2			SETTING		JRC STANDARD / MANUAL / DEFAULT	—
					IP ADDRESS			—
					SUBNET MASK			—
					MAC ADDRESS			—
					DEFAULT GATEWAY			—
		CCRP			BEAM (m)			—
					LENGTH(m)			—
	CCRP(m)						—	
	SENSOR1 (m)						—	
	SENSOR2 (m)						—	

MENU	Sub Menu	Sub Menu	Sub Menu	Sub Menu	Range	Reference	
EQUIP	CTS	CLASS				—	
		TRACKING GAIN				—	
		TRACKING HIGH				—	
		TORACING MIDDLE				—	
		TRACKING LOW				—	
		TRACKING MULTIPLE				—	
		TRACKING COUNT A				—	
		TRACKING D GAIN				—	
	LOW SPEED COG	OUTPUT				OFF/ON	—
	MAINTENANCE	DIAGNOSIS	DISPLAY				—
			PROCESSOR				—
			SENSOR1				—
			SENSOR2				—
		MONITOR	DATA IN1				—
			DATA IN2				—
			DATA IN3				—
			RS-232C				—
			SWITCH				—
			LAN1				—
			LAN2				—
			SENSOR1				—
			SENSOR2				—
				OPERATING TIME	OPERATING TIME(hr)		
	LCD TIME(hr)						—
	RESET						—
	DEMO	DEMO TYPE					—
		START/ STOP					—
		YEAR					—
		MONTH					—
		DAY					—
		HOUR(hr)					—
		MINUTE(min)					—
		SECOND(s)					—
		QUADRANT					—
		LAT					—
		LON					—
		SPEED(kn)					—
		COURSE(°)					—
		RADIUS(NM)					—
	ROUTE					—	
	ALL SETTING VALUE	BACKUP INFO					—
IMPORT/ EXPORT		MPORT/ EXPORT				PROCESSOR → DISPLAY DISPLAY → PROCESSOR	
		PROCESS				BACKUP/ OVERWRITE	

4.1.2 Function menu

DISPLAY	FUNC	
COMMON	PRINT	Outputs data to a printer.
	GOTO	Sets a waypoint.
	EVENT	Registers the own ship's position in the event mark list.
	DIMMER DEFAULT	Resets the dimmer setting to the default value.
PLOT1/PLOT2	MARK	Displays a mark at the cursor position.
	CURSOR MODE	Displays a cursor.
	HOME	Moves own ship to the centre of the screen.
	PLOT	Sets display/non-display on the plotting screen.
ANALOG	SPEED METER	Sets the maximum value of the ship speed meter.
HIGHWAY	BACK GROUND COLOUR	Changes the background colour of the HIGHWAY screen.
SAT INFO	NEAREST STN	Displays the nearest beacon station. JLR-8600 does not support this function.
BEACON TEXT	BEACON DELETE	Deletes the received data. JLR-8600 does not support this function.
	BUZZER	Sets whether to sound a buzzer when TYPE16 is received.
NAV ASSIST	CALC START	Starts distance calculation.
	TRIP RESET	Stops trip distance calculation.
	TOTAL TRIP RESET	Resets the total trip distance.
	TRIP 1 CAL START/END	Starts/Stops distance calculation of TRIP1.
	TRIP 2 CAL START/END	Starts/Stops distance calculation of TRIP2.
	TRIP 1 RESET	Resets distance calculation of TRIP1.
	TRIP 2 RESET	Resets distance calculation of TRIP2.
	CURRENT SETTING	Sets the layer of the current to be displayed.
CALC SETTING	Sets the position of two points between which the distance is to be calculated.	

4.2 Basic Operation

4.2.1 Turning on the power of the unit

When the power of the equipment is turned on by pressing the Power key, the startup screen appears.

When installation is completed, self-diagnosis starts and the setting value confirmation screen is changed to the normal screen.

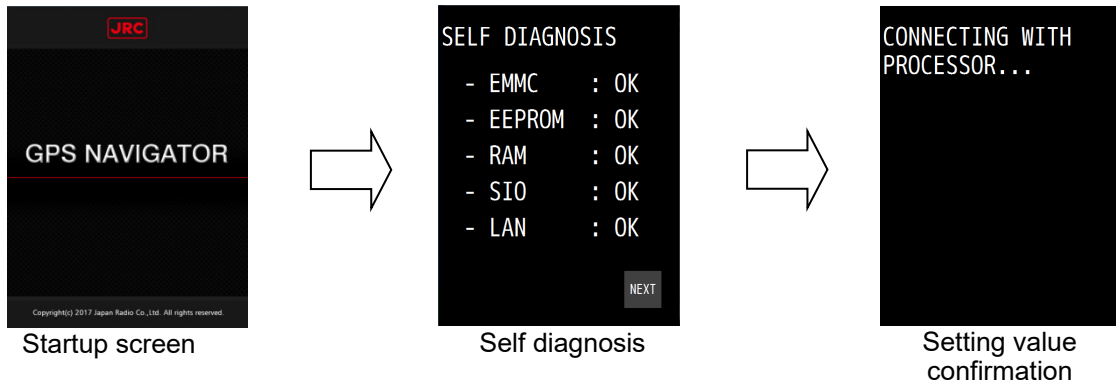

Attention

If the power for the equipment is not turned on, check the main power supply of the power board, power cable connection to the processor, or cable connection to the display unit.

4.2.2 Startup

1) Normal startup

If all the self-diagnosis results are 'OK' and all the settings of the processor and sensor settings match, the screen is switched to the normal screen automatically.

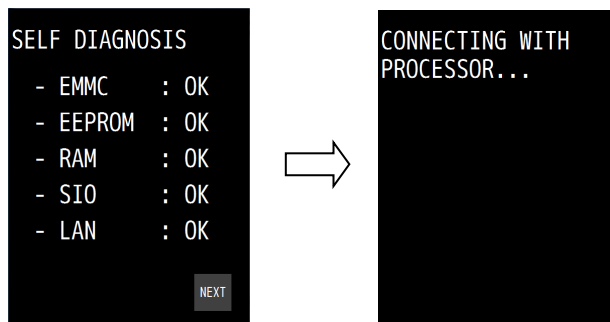

2) Error startup 1

The message that is shown below may be displayed in the receiver diagnosis.
This message is displayed when the setting values do not match between the processor and the receiver due to the equipment replacement or other reason.

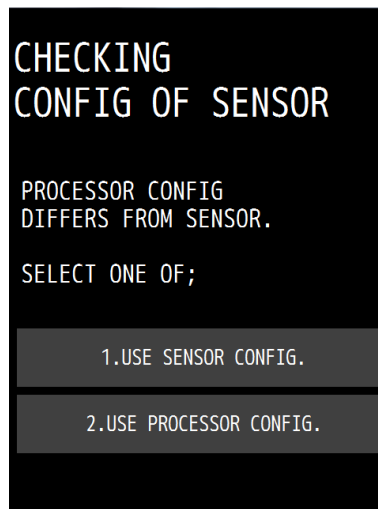

In this case, select one of the following items.

[USE SENSOR CONFIG.]: The setting value of the processor is rewritten so as to match the setting value of the receiver.

[USE PROCESSOR CONFIG.]: The setting value of the receiver is rewritten so as to match the setting value of the processor.

3) Error startup 2

If any one of the diagnosis results is 'NG', the result will be displayed continuously.
The screen is not switched to the normal screen unless "SKIP" is tapped.

Attention

When there is any error (NG), contact Nippon Signal or your distributor.

4.2.3 Turning off the power of the unit

When the Power key is pressed, the following message is displayed. When "YES" is selected, the power is turned off.

POWER OFF
ARE YOU SURE

Memo

- Even if the message is displayed, the power of the display is turned off forcibly if the Power key is held down for about 8 seconds. In this case, the power of the display is turned off, but the processor operates continuously.
- When the display unit is energised even if the power is Off, the LED of the Power key is lit.

4.2.4 Adjusting the backlight

The brightness can be adjusted to 16 levels by using the DIM key. Even if the brightness is set to OFF, the DIM key alone remains lit.

To reset the brightness to the default value, tap  from .

1. Whenever “DIM+” at the top right corner of the screen is pressed, the screen brightness increases.
2. Whenever “DIM-” at the bottom of the screen is pressed, the screen brightness decreases and finally is set to OFF.

4.2.5 Menu operation

When the MENU key is pressed, a menu is displayed.

When the MAIN key is pressed while a menu is displayed, the screen returns to the normal screen.











For the details of the menu, refer to “4.1 Menu List”.

4.2.6 Alert and acknowledgment (ACK)

1. Notifying the occurrence of an alert

When an alert occurs, an alert icon is displayed at the top left corner of the screen and the occurrence of an alert is notified by a buzzer sound. The alert target value is displayed with blinking.

Icon list

Icon	Priority	Status
	Alarm	Active-Unacknowledged
		Active-Silenced
		Active-Acknowledged
		Rectified- Unacknowledged
		Responsibility transferred
	Warning	Active-Unacknowledged
		Active-Silenced
		Active-Acknowledged
		Rectified- Unacknowledged
		Responsibility transferred
	Caution	Active

When any icon is tapped, an alert list is displayed.

2. Alert acknowledgment (ACK)

- 1) Tap the alert detail bar at the center of the screen.
- 2) The alert icon changes to the acknowledged state and the buzzer sound stops. When a NOFIX alert occurs, the alert target value that is displayed is lit in yellow.

Memo

- When multiple alerts occur simultaneously, the alert with the highest priority is displayed first and all the alerts must be acknowledged.
- Even if the alert is rectified before being acknowledged, the “Unacknowledged” state icon is displayed. All the alerts that have occurred must be acknowledged.

Screen transition at the occurrence of an alert



1. Operating normally

An alert occurrence icon is displayed.

Alert occurred

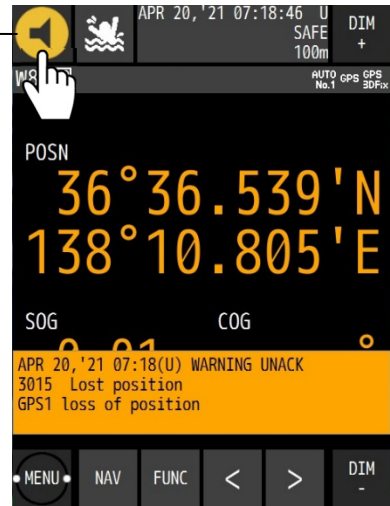

2. Alert occurred (Non ACK)

Tap the alert occurrence icon.

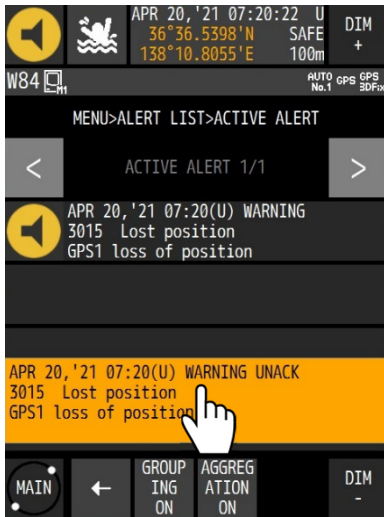

3. Alert is occurring
The alert list is displayed.

The icon indicating an acknowledged state is displayed.

Acknowledge by tapping the alert contents.

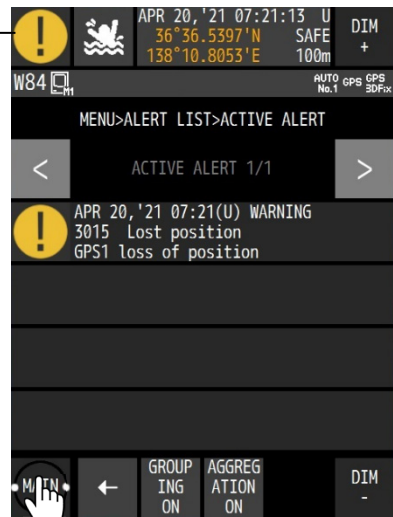

4. Alert occurred (acknowledged)

Tap the MAIN key.



5. The MAIN screen is displayed.

Rectified.



6. Rectified

4.2.7 Screen operation

See below for the screen operation.

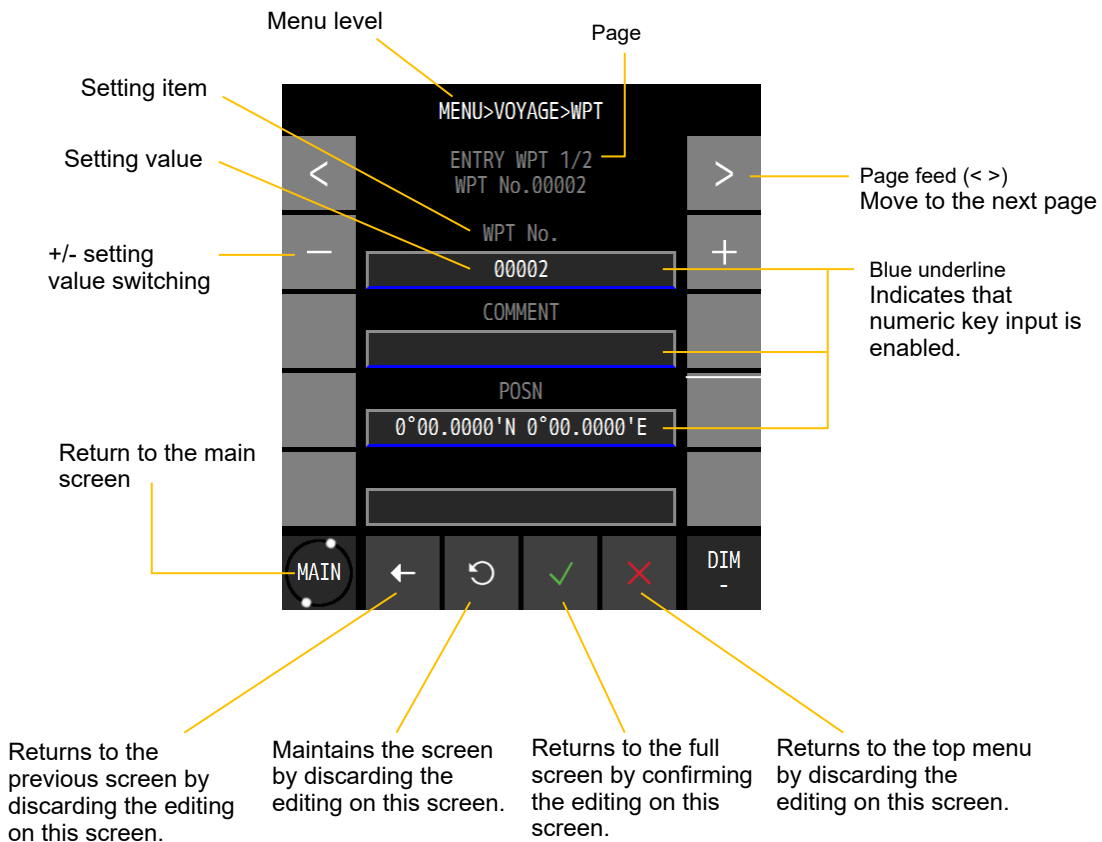

4.2.8 Inputting numeric values

Numeric value input by numeric keys is allowed for the setting values with blue underline. Tap the blue underline of the numeric item to be input.

Enter a numeric value and confirm with .

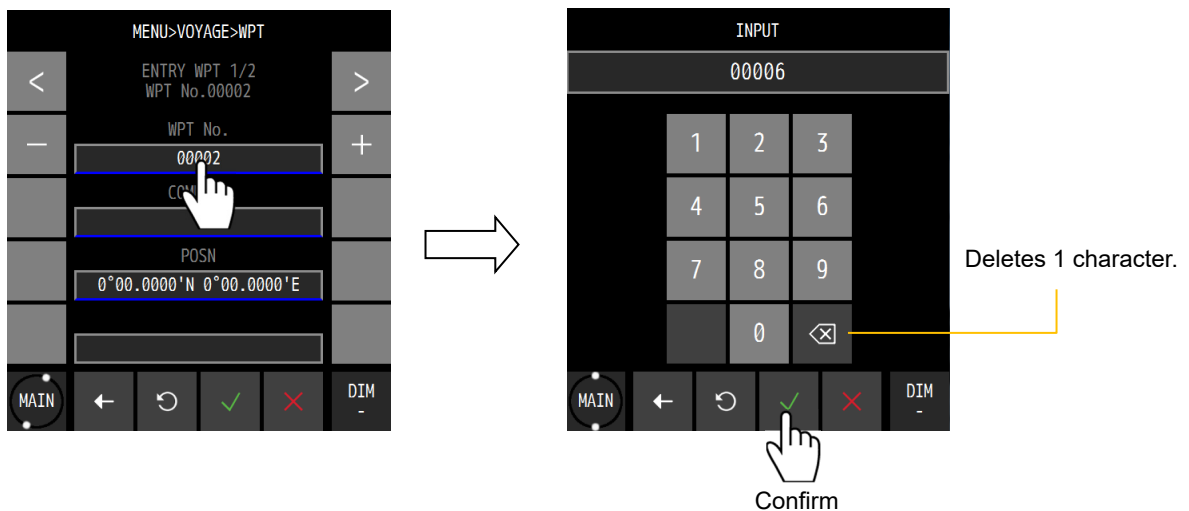

4.2.9 Inputting comments

Input of characters by using numeric keys is allowed for the setting items with blue underline. Tap the blue underline of the setting item to be input. Change the input mode by tapping ABC (characters), #&\$ (symbols), or 123 (numeric values). Display the character or numeric value that is assigned to the key by tapping it. When entering the same character or symbol consecutively, take a small interval between them.

Enter a character and confirm it with .

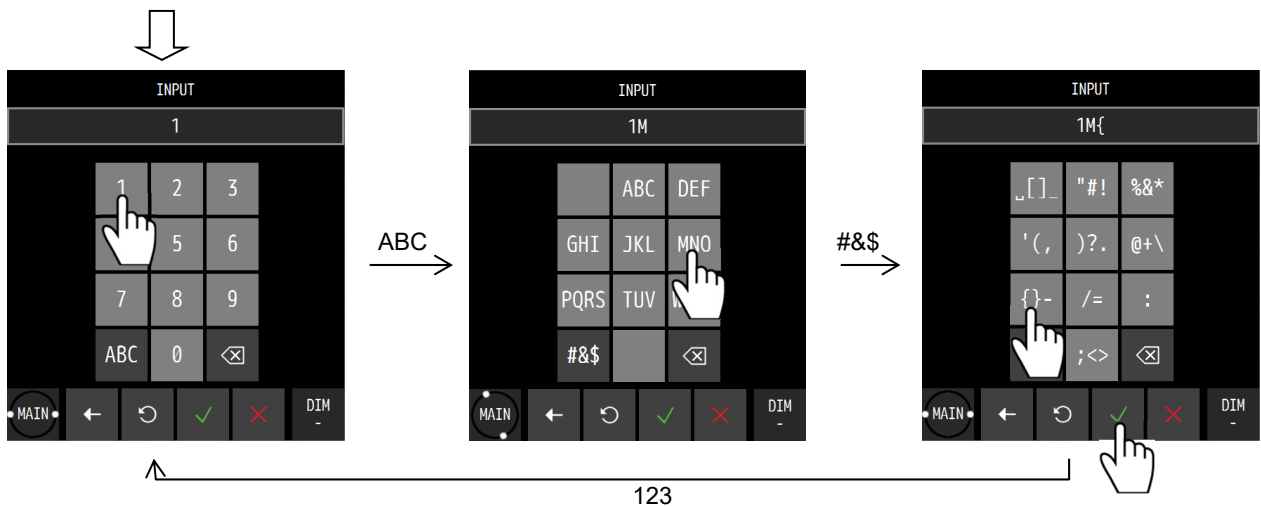
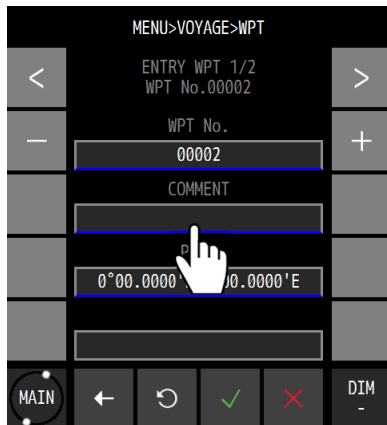

4.2.10 List operation

This section shows the list operation method.

The same operation method is applied for a waypoint list, a route list, and an event mark list.

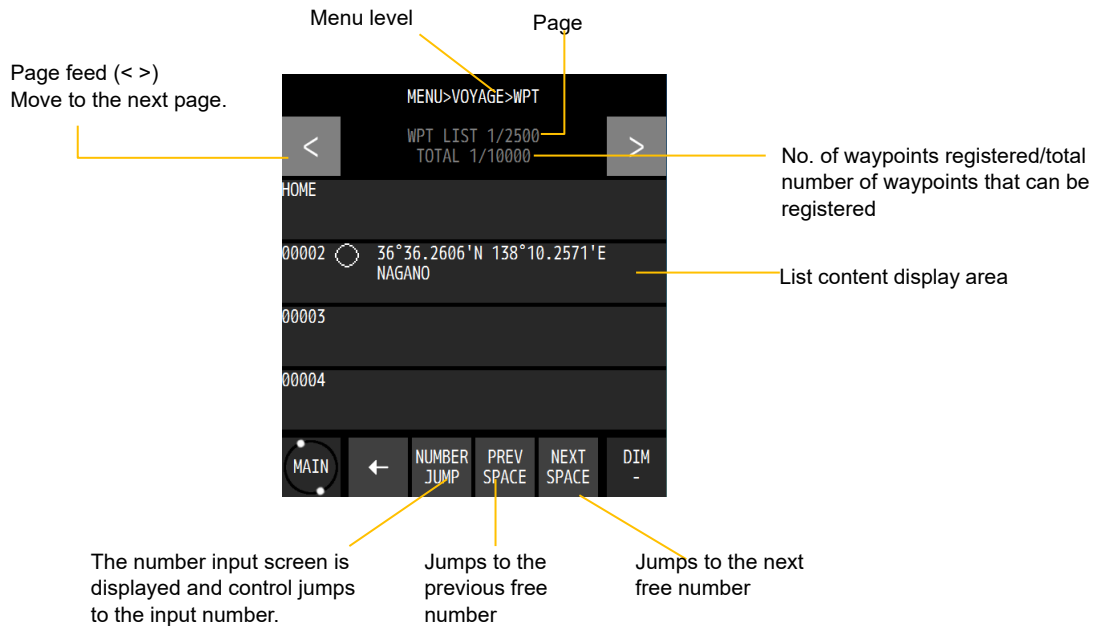

When the list is empty, the following message is displayed.

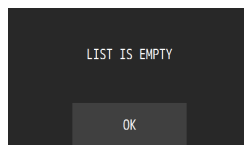

4.2.11 Entering a password in CODE INPUT

Some setting items are protected by a password to prevent them being changed easily.

If the power is turned off or no operation is performed for five minutes after a password is set, the password is reset.

To set a password, enter a password again in CODE INPUT.

Procedure

1. →

2. Enter a password and confirm it with .

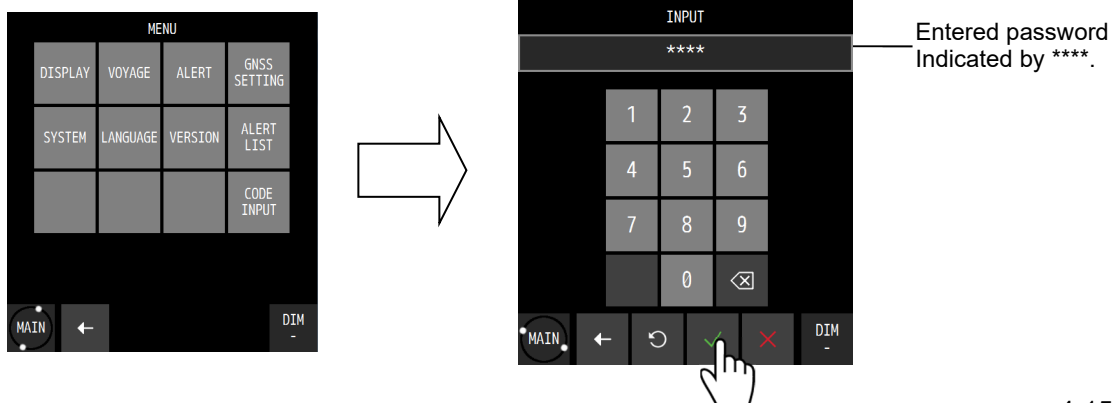

4.3 Setting Display

Set a screen.

Set a THEME, a beep tone, and background colour.

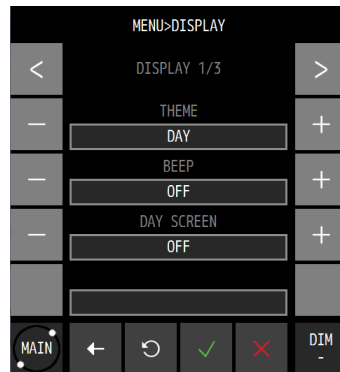

4.3.1 Setting a theme

Screen brightness can be adjusted according to the time zone for using this equipment.

Procedure

1.  →  → THEME

THEME	Description
DAY	Specify this when using the equipment during daytime.
DUSK	Specify this when using the equipment at dusk.
NIGHT	Specify this when using the equipment at night.

4.3.2 Setting a beep tone

Set a beep tone ON/OFF when the screen is tapped.

Procedure

1.  →  → BEEP

BEEP	Description
ON	Sets the beep tone to ON.
OFF	Sets the beep tone to OFF.

4.3.3 Setting reverse video display

Set the background colour to white/black.

Procedure

1.  →  → DAY SCREEN

DAY SCREEN	Description
ON	Sets the background colour to white.
OFF	Sets the background colour to black.

4.3.4 Selecting a display screen

A screen to be displayed can be selected.
It is not possible to set all the screens to non-display.

Procedure

1.  →  →   → Select a display.

DISPLAY	Description
NAV	
PLOT1	ON: Set to Display.
PLOT2	OFF: Set to Non-display.
ANALOG	
HIGH WAY	
SAT INFO	
WPT INFO	
BEACON TEXT	
NAV ASSIST	

4.4 Registering Waypoints



- To execute a route, a waypoint must be registered in a waypoint list.
- This equipment allows registration of 10000 waypoints.
- A waypoint list is divided into three areas and it is managed by numbers from 1 to 11024.
 - 1 to 10000: Waypoints that are registered in this equipment are registered.
 - 10001 to 10512: Waypoints of the shared active routes that are sent from ECDIS are registered.
 - 10513 to 11024: Waypoints that were used by a temporary route are registered.
- While waypoints from number 1 to number 10512 are saved and are not cleared even if the power is turned off, waypoints from number 10513 to number 11024 are cleared if the power is turned off.
- Waypoints can be set up to North latitude/South Latitude 89 degrees.

4.4.1 Displaying a waypoint list

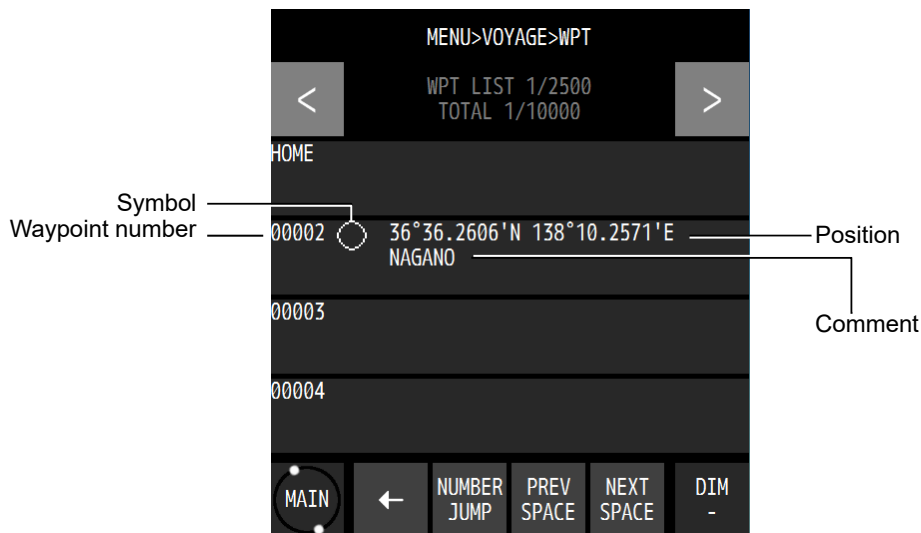
Registered waypoints (waypoint numbers from 1 to 10000) can be displayed. Waypoint number 00001 is registered as “HOME PORT”.



Procedure

1.  →  →  → A waypoint list is displayed.

Memo

- The position that is registered in HOME in a waypoint list can be set easily as a waypoint by the GOTO function. It is useful to register a point that is set as a waypoint frequently (such as home port). The GOTO function can be set from  on each screen.



4.4.2 Registering waypoints

The following five positions can be registered in a waypoint list.

- (1) Own ship's position
- (2) Any latitude and longitude
- (3) Cursor position
- (4) Position measured by the bearing and distance from any position
- (5) Position that is registered in an event/mark list

Up to 10000 points can be registered.

Procedure

1.  →  →  → A waypoint list is displayed.

2. Tap the number you want to register.

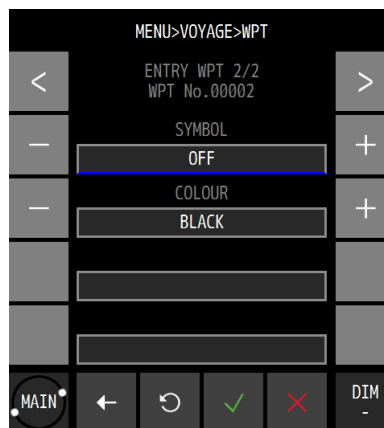
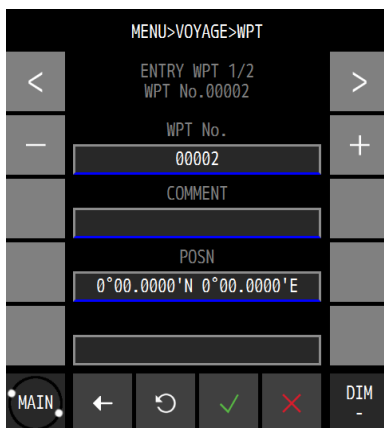

Item	Description
WPT No.	Enter a waypoint number.
COMMENT	Enter a comment.
POSN	Enter a waypoint position.
SYMBOL	Select a symbol.
COLOUR	Select a symbol colour.

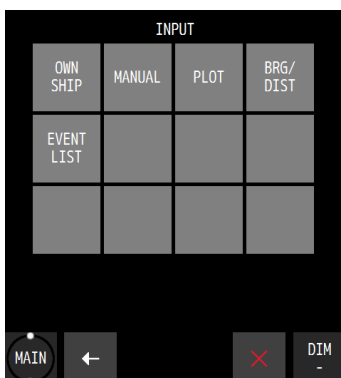

3. Tap "POSN".
4. A registration method selection screen is displayed.



The registration method submenu is outlined below.

- (1) OWN SHIP: Register an own ship's position.
- (2) MANUAL: Register any latitude and longitude.
- (3) PLOT: Register a cursor position from the plotting screen.
- (4) BEG/DIST: Register based on the bearing/distance from any position.
- (5) EVENT LIST: Register from an event mark list.

(1) When selecting OWN SHIP

- a) Tap  .
- b) Set a comment, a symbol, and a colour, and tap  .

(2) When selecting MANUAL

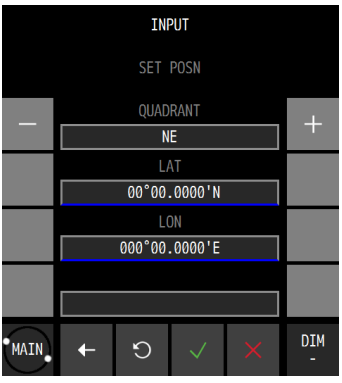
- a) Tap  .
- 

Item	Description
QUADRANT	Select North latitude/South latitude/East latitude/West latitude of the latitude/longitude.
	NE North latitude/East latitude
	NW North latitude/West latitude
	SE South latitude/East latitude
	SW South latitude/West latitude
LAT	Enter a latitude.
LON	Enter a longitude.

- b) Set a comment, a symbol, and a colour, and tap  .

(3) Selecting PLOT

- a) Tap  .
- b) A plotting screen is displayed.
- c) Move the cursor to the position you want to register by using the Up/Down/Left/Right arrows.
- d) Tap "SET".
- e) The cursor position is registered.

Cursor position
Bearing/distance from own ship to the cursor position

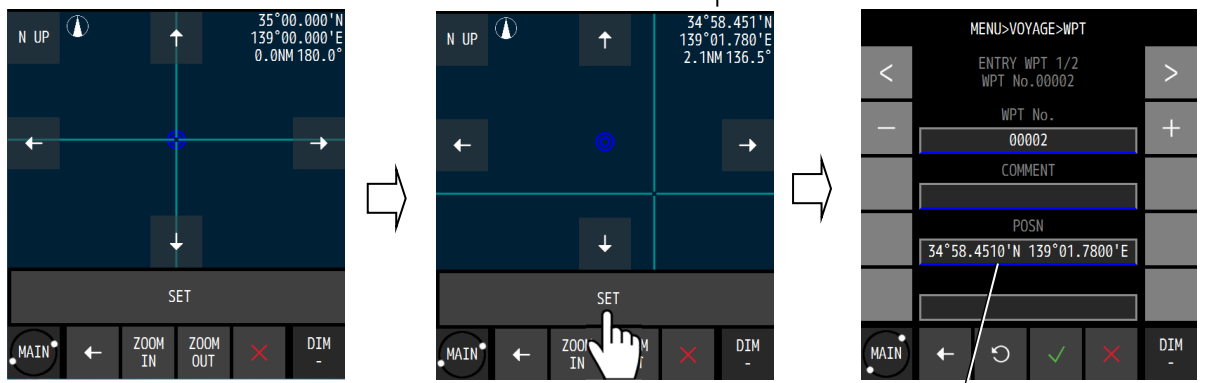

Registered waypoint

- f) Set a comment, a symbol, and a colour and tap  .

(4) Selecting BRG/DIST

- a) Tap .
- b) When a waypoint position screen is displayed, tap WPT POSN.

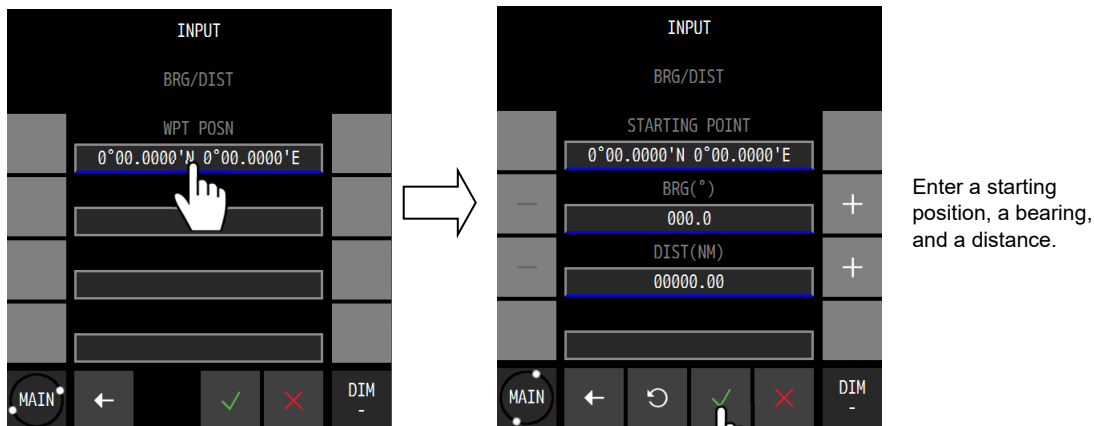



- c) Set a starting position, a bearing, and a distance.

The submenu for setting a starting position is outlined below.

- (1) OWN SHIP: Set an own ship's position.
- (2) MANUAL: Set any latitude and longitude.
- (3) PLOT: Set a cursor position from the plotting screen.
- (4) WP LIST: Select from a waypoint list.
- (5) EVENT LIST: Select from an event mark list.
- (6) PRE WPT: Set the previous waypoint as the starting position.

Item	Description
STARTING POINT	Enter a starting point.
BRG	Enter a bearing.
DIST	Enter a distance.

- d) Confirm the setting by tapping .
- e) Set a comment, a symbol, and a colour and tap .

(5) Selecting EVENT LIST

- a) Tap .
- b) An event mark list is displayed.
- c) Select a number of the event mark you want to register.

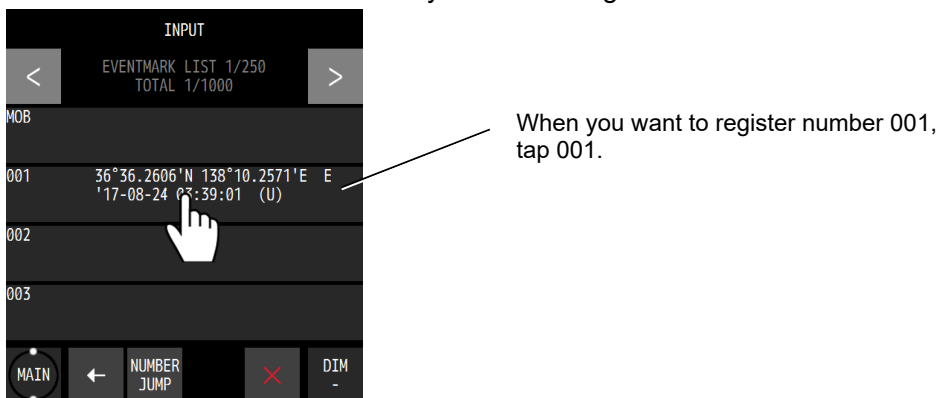





- d) Set a comment, a symbol, and a colour and tap .

4.4.3 Editing waypoints

- Registered waypoint information (symbol shape, comment, and waypoint position) can be edited.
- The waypoint on the route that is currently being executed cannot be edited.

Procedure

1.  →  →  → A waypoint list is displayed.
2. Tap the number you want to edit.
3. Tap the item you want to edit and edit the item.
4. After editing, tap .



To edit a position, refer to “4.4.2 Registering waypoints”.

A symbol, a colour, and a comment can be edited from the plotting screen. For the editing method, refer to “4.8.10 Displaying symbol information”.

4.4.4 Copying waypoints

- Waypoint information can be copied on to another waypoint number. Information on an event and a mark can be copied on to a waypoint list. Number 1 in a waypoint list is handled as HOME.
- Waypoints that are saved under numbers from 10001 to 10512 and are used by the shared active route that is sent from ECDIS are automatically overwritten when next route is sent. Waypoints to be kept must be copied under numbers between 1 and 10000.
- Waypoints of a temporary route that are saved under numbers from 10513 to 11024 are cleared when another temporary route is created or the power is turned off. Waypoints to be kept must be copied under numbers between 1 and 10000.
- When no free area is available, waypoints can be overwritten. However, waypoints cannot be overwritten to those that are used by the route.

Procedure

1.  →  → 
 2. Enter a starting point and an ending point of the copy source.
When only one point is to be copied, enter the same number for a starting point and an ending point.
 3. Tap a copy destination. The copy destination submenu is outlined below.
 - (1) Any input: Enter an input number.
 - (2) Waypoint list: Specify from a waypoint list.
- (1) **Any input**
Enter a starting point of the copy destination.
 - (2) **Waypoint list**
When a waypoint list is displayed, tap a number of the copy destination.

4. Confirm the operation by tapping .

Memo

- When selecting copy sources with consecutive numbers, numbers that cross over a boundary such as 10000 or 10512 cannot be selected.
Example) Numbers from 9999 to 10001 or numbers from 10511 to 10513 cannot be selected.

4.4.5 Deleting waypoints

- Waypoints registered from numbers 1 to 10000 can be deleted.
- Waypoints on the route that is currently executed cannot be deleted.
- If a waypoint is on the route that is not being executed is deleted, the waypoint is deleted from the route also.

Procedure



2. Tap a deletion source. A deletion source submenu is outlined below.

- (1) Any input: Enter a waypoint number to be deleted.
- (2) Waypoint list: Specify from a waypoint list.
- (3) ALL: All the waypoints are deleted.

(1) Any input

Enter a starting point and an ending point of the number of the waypoint to be deleted.
When deleting one point only, enter the same number for a starting point and an ending point.

(2) Waypoint list

When a waypoint list is displayed, select a starting point and an editing point of the waypoints to be deleted.
When deleting one point only, enter the same number for a starting point and an ending point.

(3) All

All the waypoints are deleted.

3. The range to be deleted and the number of waypoints to be deleted are displayed.

4. Confirm the selection by tapping .

Waypoints can be deleted from a plotting screen. For the editing method, refer to “[4.8.10 Displaying symbol information](#)”.

4.5 Route Plan

- A route can be created by using registered waypoints.
- Up to 100 routes can be created in this equipment and up to 512 waypoints can be specified per route. Waypoint information can be set for each LEG such as a route width, an arrival radius, and GC/RL.

For the waypoint information that can be set, refer to “4.5.1 Displaying a route list”.

- A created route can be shared with external equipment such as ECDIS.
- A created route is registered in a route list.
- A route list is divided into three areas and is managed by numbers from 1 to 102.
 - Numbers from 1 to 100: The route that was created in this equipment is registered.
 - Number 101: The shared active route that is sent from ECDIS is registered.
 - Number 102: A temporary route is registered.
- Since routes from numbers 1 to 101 are saved, they are not cleared even if the power is turned off. However, route number 102 is cleared if the power is turned off since it is not saved.

4.5.1 Displaying a route list

Routes that were created can be displayed in a route list. Information on each LEG of the route and waypoint information of each LEG can be displayed.

The required time cannot be calculated for the route that contains the LEG without planned ship speed.

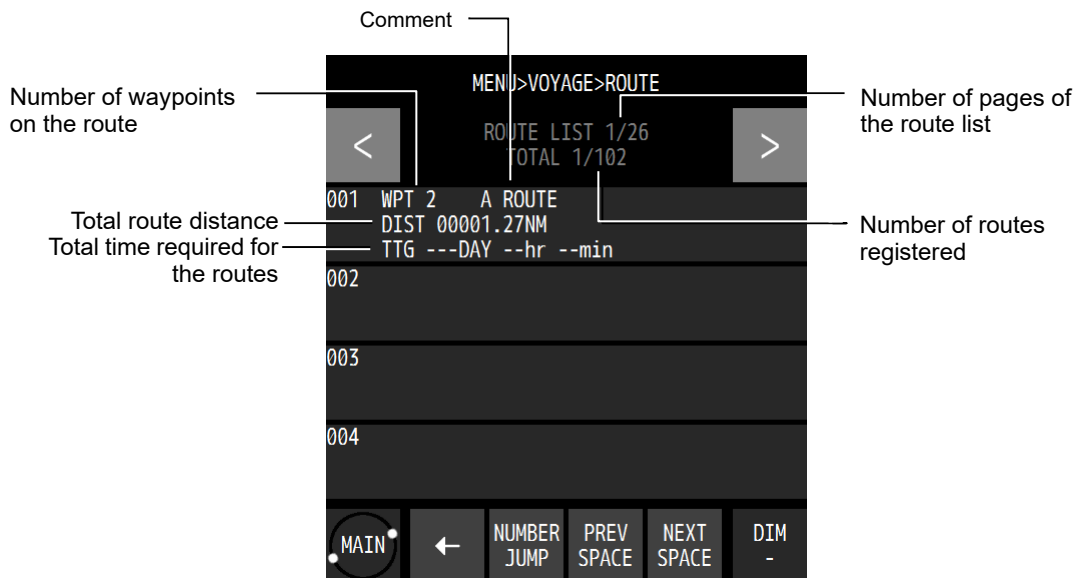

Procedure

1.  →  →  → A route list is displayed.

When a registered route is tapped, the LEG information can be displayed.

4.5.2 Creating routes

- To create a route, determine a route number and sequentially select the waypoints, which are turn points.
- The same waypoint cannot be selected continuously.
- Up to 100 routes can be created.
- Up to 512 waypoints can be set per route.
- Either a TCS route or a normal route can be selected.

Procedure

1.  →  →  → A route list is displayed.

2. Tap a number to be registered.

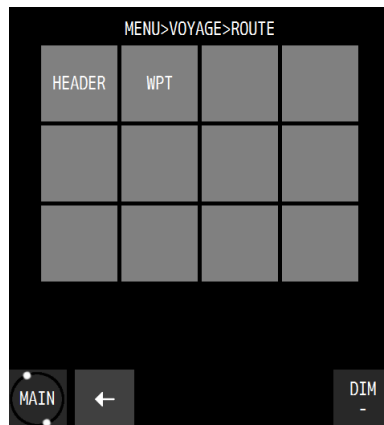

3. Tap  .

Item	Description	
ROUTE	ARRIVAL CIRCLE	Creates a normal route.
	WHEEL-OVER LINE(WOL)	Creates a TCS route.
COMMENT	Enter a comment.	

4. Tap  .

When a waypoint input screen is displayed, tap 001.

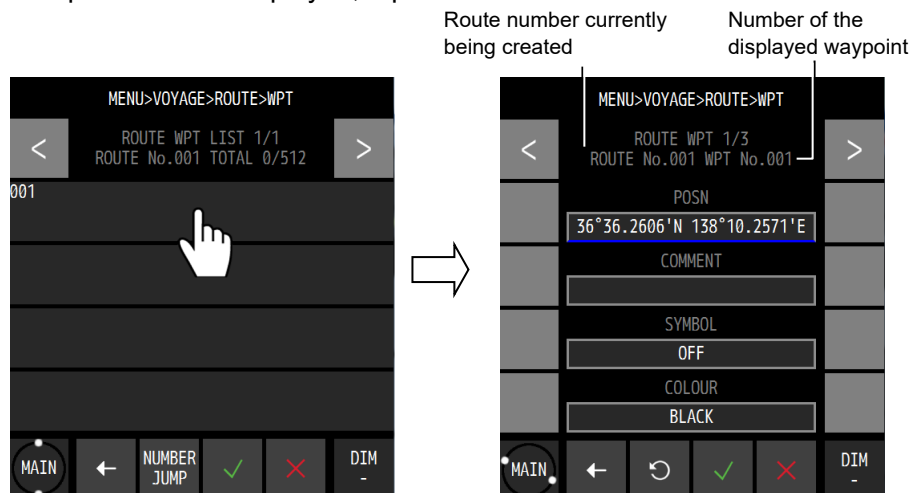

Item	Description
POSN	When "POSN" is tapped, a waypoint list is displayed. Select a waypoint position from the waypoint list.
COMMENT	A comment cannot be set for a waypoint. It can be edited from the waypoint list.
SYMBOL	A waypoint symbol cannot be set. It can be edited from the waypoint list.
COLOUR	A colour of a waypoint cannot be set. It can be edited from the waypoint list.
ARRIVAL RADIUS	Set an arrival radius.
WIDTH PORT	Set a port route width.
WIDTH STBD	Set a starboard route width.
SPEED	Set a planned ship speed.
SAIL	Route distance calculation method for LEG GC: Calculated by the great circle sailing. RL: Calculated by the Meridional part sailing (Rhumb Line).
STATE	Set whether to use the waypoint. USE: Use the waypoint. SKIP: Although the waypoint is kept on the route, it is skipped. DELETE: The waypoint is deleted from the route. It is kept in the waypoint list. Waypoints of the route that is currently being executed cannot be deleted.
ROT	This item can be set for a TCS route only. Set a Rate Of Turn.
TURN RADIUS	This item can be set for a TCS route only. Set a turn radius.
TIME ZONE	This item can be set for a TCS route only. Set a time zone.

5. Set each item and tap .

First waypoint is set. To set two or more waypoints, repeat from Step 4.

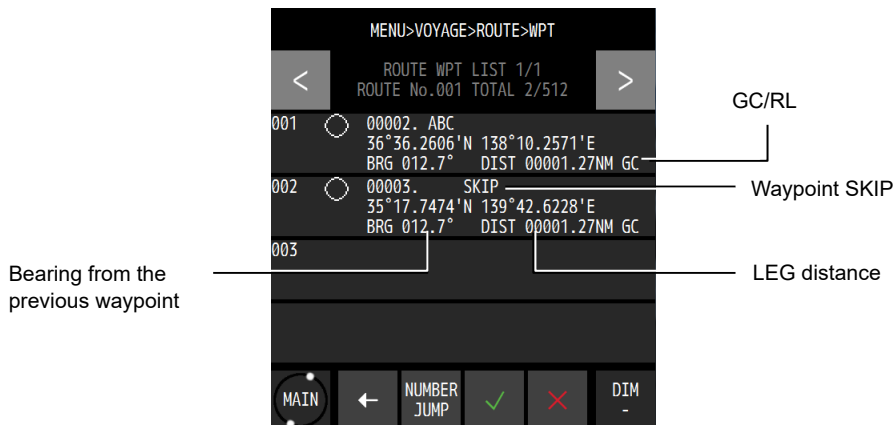





6. Set a waypoint and tap .

4.5.3 Editing routes

Waypoint addition, change, and deletion are allowed for routes.

Procedure

1.  →  →  → A route list is displayed.
2. Tap a route you want to edit.
3. Tap .
4. Tap a waypoint you want to edit.

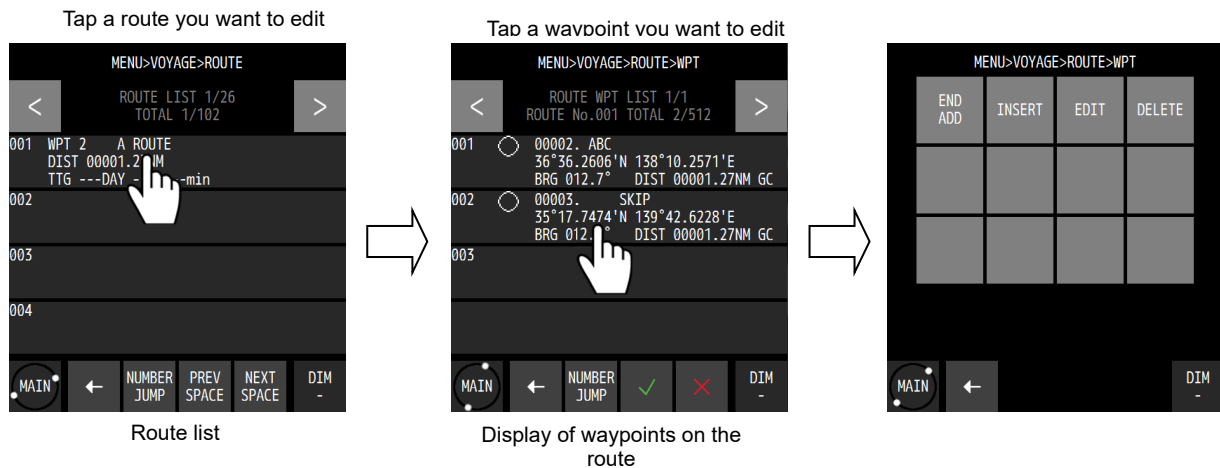

Item	Description
END ADD	Adds the final waypoint.
INSERT	Adds a waypoint before the waypoint that is tapped.
EDIT	Edits the waypoint that was tapped.
DELETE	Deletes the waypoint that was tapped from the route.

5. Set a waypoint and tap .

Headers can also be edited in the same way.

4.5.4 Copying routes

The route that was created can be copied on to a different route number.

The waypoint that is used by the shared active route and is sent from ECDIS and is saved in number 101 is overwritten automatically when the next route is sent. Routes that are to be saved must be copied on to numbers between 1 and 100.

The waypoint of a temporary route that is saved under number 102 is cleared when another temporary route is created or the power is turned off. To save the route, the route must be copied on to a number between 1 and 100.

Routes of consecutive numbers can be copied in bulk.

When no free area is available, a route can be overwritten. However, the route that is being executed cannot be overwritten.

Select a copy source and specify a copy destination number.

When a temporary route or a shared route is to be copied, the waypoints must also be copied.

Procedure

1.  →  → 

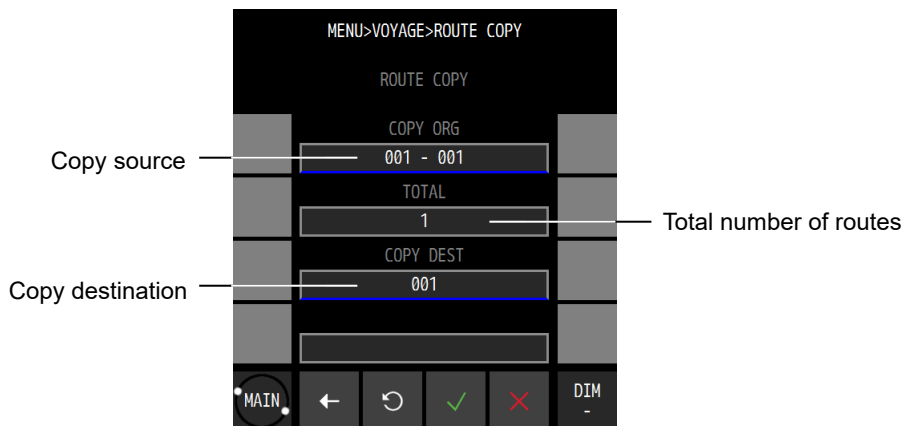

2. Tap "COPY ORG" and enter a number of a starting point and an ending point of the copy source.

The input method is outlined below.

- (1) MANUAL: Enter an ending point and a starting point.
- (2) ROUTE LIST: Select from the route list.

When copying one point only, enter the same number for a starting point and an ending point.

(1) MANUAL input

- a) Tap .

Item	Description
FROM	Set a starting number.
TO	Set an ending number.

(2) Selecting from a ROUTE LIST

- a) Tap .

- b) Tap a starting point and an ending point on the route list.

c) Confirm the setting by tapping .

3. Tap "COPY DEST" and enter a starting point of the copy destination.

The input method is outlined below.

- (1) MANUAL: Enter an ending point.
- (2) ROUTE LIST: Select from the route list.

(1) MANUAL input

a) Tap .

Item	Description
INSART	Set a copy destination number.

b) Confirm the setting by tapping .

(2) Select from a ROUTE LIST

a) Tap .

b) Tap a copy destination on the route list.

c) Confirm the setting by tapping .

4. Execute by tapping .

4.5.5 Deleting routes

- Registered routes from numbers 1 to 100 can be deleted.
- The waypoints of the route to be deleted can be deleted concurrently.
- When deleting waypoints also, the waypoints that are used by another route cannot be deleted.
- An Active route cannot be deleted.

Procedure

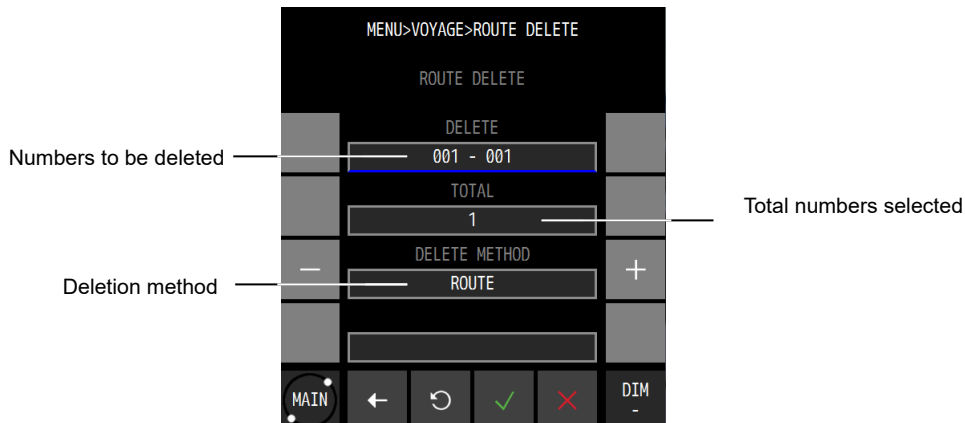

2. Tap "DELETE" and enter a number of a starting point and an ending point of the deletion source.

The input method is outlined below.

- (1) MANUAL: Enter an ending point and a starting point.
- (2) ROUTE LIST: Select from the route list.
- (3) ALL: All the routes are deleted.

When copying one point only, enter the same number for a starting point and an ending point.

(1) MANUAL input

- a) Tap  .

Item	Description
FROM	Set a starting number.
TO	Set an ending number.

(2) Selecting from a ROUTE LIST

- a) Tap  .

- b) Tap a starting point and an ending point on the route list.

- c) Confirm the selection by tapping  .

(3) Selecting ALL

- a) Tap  .

All the routes are selected.

3. Tap "DELETE METHOD" and select a deletion method.

DELETE METHOD	Description
ROUTE	Only the selected route is deleted. The waypoint is not deleted.
ROUTE+WPT	The selected route and the waypoint on the route are deleted.

4. Tap  and execute the deletion.

4.5.6 Sharing a route with another piece of equipment

The route that was created by this equipment can be sent to EDCIS or a radar and also the route that was created by ECDIS can be shared by receiving it (Data route sharing). To use the route sharing function, equipment (ECDIS or radar) corresponding to the sharing must be connected to LAN.

Procedure

1.  →  → 

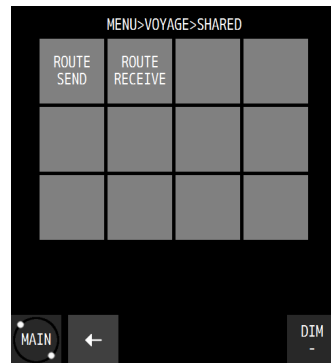

Item	Descriptions
ROUTE SEND	Sends a route.
ROUTE RECEIVE	Sets route reception.

(1) Sending a route

- a) Tap .

- b) Set each item.

Item	Description	
CONNECT	Select multicast , unicast, or broadcast. Normally, "multicast" is selected.	
IP	Set a destination ID when selecting unicast. When the multicast is selected, set to address "239.000.096.001".	
PORT	Set a destination port when selecting unicast. When the multicast is selected, set to port "6203".	
OUTPUT	Set a LAN port for output.	
FORMAT Normally, "JRC" or "SHARE ROUTE" is selected.	NMEA VER1.5	Sends under the RTE/WPL sentence of NMEA Ver 1.5.
	NMEA VER2.1	Sends under the RTE/WPL sentence of NMEA Ver 2.1.
	NMEA VER2.3	Sends under the RTE/WPL sentence of NMEA Ver 2.3.
	NMEA VER4.0	Sends under the RTE/WPL sentence of NMEA Ver 4.0.
	IEC	Sends under the RTE/WPL sentence of IEC.
	JRC	Sends the route in the JRC format. Select the "JRC", when the route is shared between GPS Navigator.
SHARE ROUTE	Use ROUTE to set the route to be sent. Select the "SHARE ROUTE", when the route is shared with ECDIS.	
DATA	Select the data to be sent.	
	ALL WPT	Sends all the waypoints.
	ALL WPT+ROUTE	Sends all the waypoints and routes.
	SELECT WPT+ROUTE	Sends the selected route and the waypoint.
	ALL ROUTE	Sends all the routes.
SELECT ROUTE	Sends the selected route.	

ROUTE	This item can be set when SHARE ROUTE is selected. Select a route to be sent.
TOTAL	This item can be display when SHARE ROUTE is selected. Displays the number of selected routes.

A ROUTE can be selected manually or from a route list.

c) When  is tapped, the route is sent.

(2) Receiving a route

a) Tap .

Item	Description
SOURCE IP	Set a sending source IP.

b) Tap  to set the sending source.

Memo

- When the Active route is shared, it will not stop on the GPS even if the active route stops with ECDIS. To stop the active route on the GPS, refer to "4.6.3 Ending a route".

4.5.7 Setting route initial values

Set an initial value of each parameter of the route.
The values are applied to the route that was created by GOTO.

Procedure

1.  →  → 

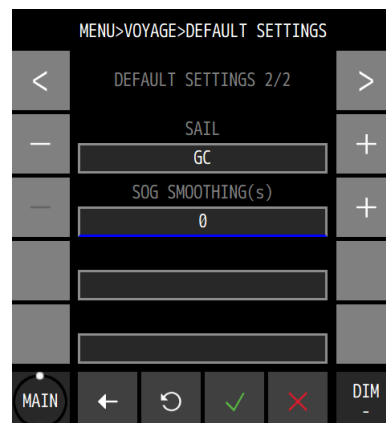
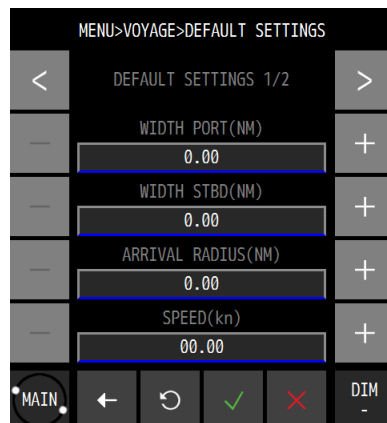

2. Set each item.

Item	Description
WIDTH PORT	Set a port route width.
WIDTH STBD	Set a starboard route width.
ARRIVAL RADIUS	Set an arrival radius.
SPEED	Set a planned ship speed.
SAIL	Route distance calculation method for LEG GC: Calculated by the great circle sailing. RL: Calculated by the Meridional part sailing (Rhumb Line).
SOG SMOOTHING	Set a SOG smoothing constant. Smoothing is applied to the ship speed for calculating the estimated time of arrival and the estimated time required. Smoothing can be applied up to 99 seconds. When the estimated time of arrival fluctuates significantly, increase the smoothing value.

3. Confirm the setting by tapping .

Memo

- Do not set 0.00NM to the WIDTH PORT/STBD, route can not be shared with ECDIS.

4.6 Executing a Route

- A registered route or a temporary route can be executed.
- The following route selection methods are available.
 - (1) Select a route from a route list.
 - (2) Select a waypoint by using the GOTO key.
 - (3) Select a route by using the GOTO key.
 - (4) Select a temporary route by using the GOTO key.
- A route cannot be executed at the position exceeding North latitude/South latitude 89 degrees.
- For the route width, arrival radius, planned ship speed of the temporary route that was created by GOTO, the initial values of the route are used. For the setting of route initial values, refer to "4.5.7 Setting route initial values".
- The waypoint is updated when the ship arrives at the arrival circle.

4.6.1 Executing a route by selecting from a route list

A route can be executed by selecting from a route list.

Procedure

1.  →  → 

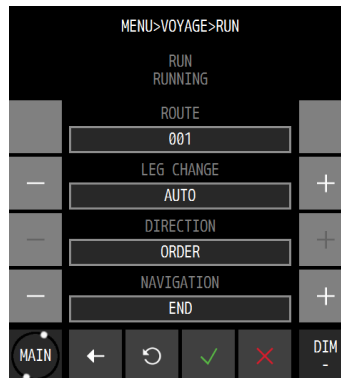

2. Set each item.

Item	Description
ROUTE	Displays the route number to be executed.
LEG CHANGR	Select a waypoint update method. AUTO: When the ship arrives at the arrival circle (normal route) or WOL (TSC route), the waypoint is updated automatically. WPT AUTO is displayed. "WPT CHANGE" is displayed for 5 seconds. MANUAL: When the ship arrives at the arrival circle (normal route) or WOL (TSC route), the effect is notified to the user. The waypoint is to be updated manually. WPT MAN is displayed. "PLEASE PUSH "OK" AND CHANGE A ROUTE is displayed. Tap "OK". The waypoint is updated.
DIRECTION	Set an order of the waypoints to be executed. ORDER: Executes the route in the order of waypoints. REVERSE: Executes the route starting from the last waypoint.
NAVIGATION	Executes the route. START: Executes the route. END: Ends the route.

3. Select "START" in "NAVIGATION".

4. Execute the route by tapping .



4.6.2 Selecting a waypoint/route by using the GOTO key

When a waypoint or a route is selected by using GOTO that is assigned to "FUNC" of each screen, the route is executed towards the waypoint.

When a waypoint on the route that is being executed is selected by using the GOTO key, the route restarts from the waypoint.

The route that was created by GOTO is registered under route number 102 as a temporary route.

Procedure

1. Each screen →  → 

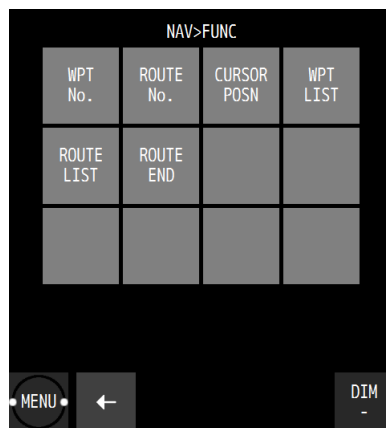

The GOTO submenu is outlined below.

- (1) HOME: Sets HOME in the waypoint list as the waypoint.
- (2) WPT No.: Enter a waypoint number.
- (3) ROUTE No.: Enter a route number.
- (4) EVENT No.: Enter an event number.
- (5) CURSOR POSN: The cursor position is specified as the waypoint (a temporary route can be created by setting up to 512 waypoints).
- (6) WPT LIST: Select from a waypoint list.
- (7) ROUTE LIST: Select from a route list.
- (8) EVENT LIST: Select from an event list.
- (9) ROUTE END: The route can be ended during the execution of the route.

(1) Entering "HOME"

a) Tap  .

(2) Entering a waypoint number

a) Tap  and enter a waypoint number.

b) Execute by tapping .

(3) Entering a route number

a) Tap  and enter a waypoint number.

b) Execute by tapping .

(4) Entering an event number

a) Tap  and enter an event number.

b) Execute by tapping .

(5) Specifying the cursor position as the waypoint

a) When  is tapped, a plotting screen is displayed.

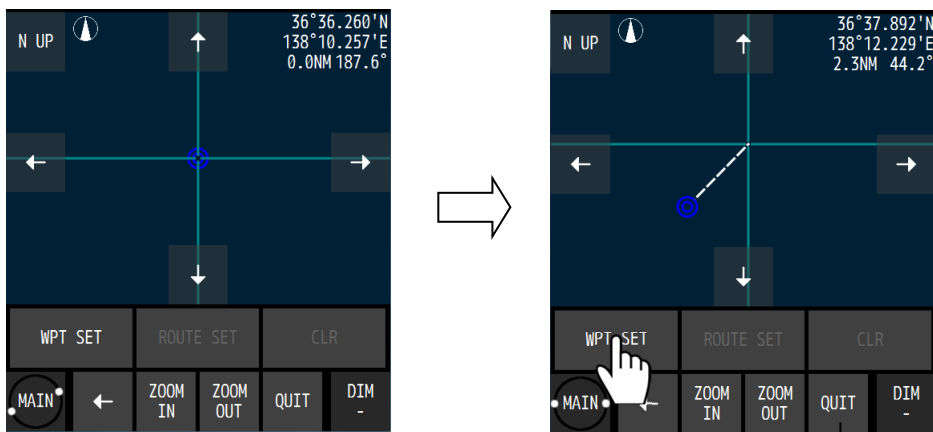

b) Move the cursor to the waypoint and tap "WPT SET".

Cancels GOTO processing

To create a route, repeat the operation b).
To delete a waypoint, tap "CLR".

c) Tap "ROUTE SET".

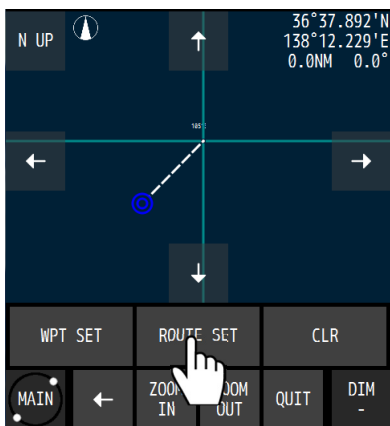

d) The following popup window is displayed.

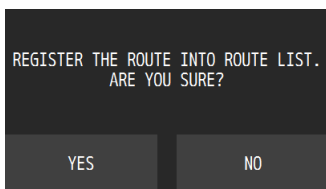

Item	Description
YES	Registers the route in the route list. When a route list is displayed, set a route number.
NO	Stores the route as a temporary route. A temporary route is cleared when the power is turned off.

(6) Selecting a waypoint from a waypoint list

- a) When  is tapped, a waypoint list is displayed.
- b) Tap the number to be set as for the waypoint.

(7) Selecting from a route list

- a) When  is tapped, a waypoint list is displayed.
- b) Tap the route number to be executed.
- c) Select a waypoint update method and an execution sequence.

Item	Description
LEG CHANGE	Select a waypoint update method.
	AUTO: When the ship arrives at the arrival circle (normal route) or WOL (TSC route), the waypoint is updated automatically. WPT AUTO is displayed. "WPT CHANGE" is displayed for 5 seconds.
	MANUAL: When the ship arrives at the arrival circle (normal route) or WOL (TSC route), the effect is notified to the user. The waypoint is to be updated manually. WPT MAN is displayed. "PLEASE PUSH "OK" AND CHANGE A ROUTE" is displayed. Tap "OK". The waypoint is updated.
DIRECTION	Set a direction of the waypoints to be executed. ORDER: Executes the route in the order of waypoints. REVERSE: Executes the route starting from the last waypoint.

d) Select "START" in "NAVIGATION".

(8) Selecting from an event list

- a) Tap  to display an event list.
- b) Tap the number to be set as the waypoint.

(9) Ending the route that is currently being executed

- a) Tap  .
- b) The following popup window is displayed.

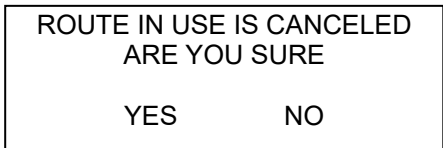





- c) Tapping YES will end the route.

4.6.3 Ending a route

End a route.

Procedure

- 1.  →  → 
- 2. Select "END" in "NAVIGATION".
- 3. Execute by tapping  .

Ending by using GOTO

- 1.  → 

- 2. Tap  .

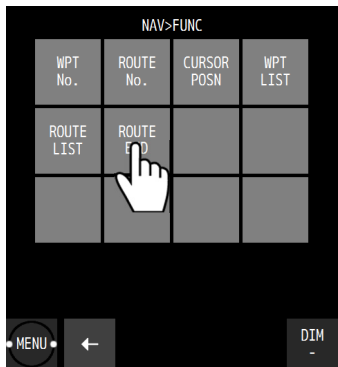

- 3. The following popup window is displayed.

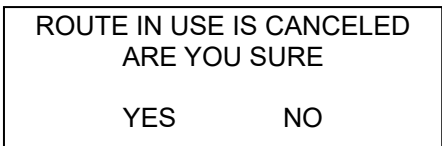

- 4. Tapping YES will end the route.

4.7 Event/Mark

- Events, marks, MOB, and lines are registered in an event mark list.

4.7.1 Displaying an event/mark list

- All the registered events and marks can be displayed in a list.
- MOB is registered under event number 000.

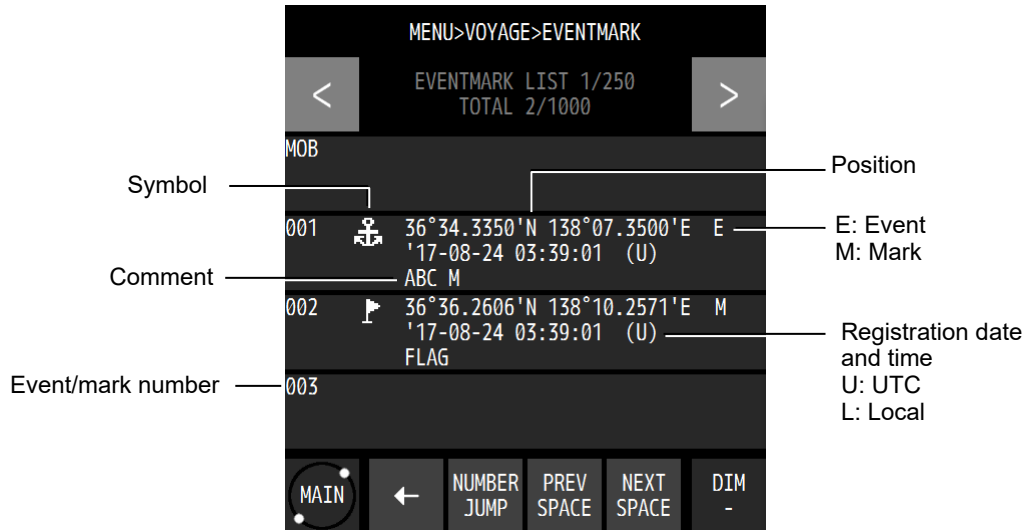

Procedure

1. MENU → VOYAGE → EVENT MARK

4.7.2 Registering events

Register an own ship's position as an event.

Procedure

1. FUNC → EVENT

Registering from a screen

1. Tap the position display section at the top of the screen.

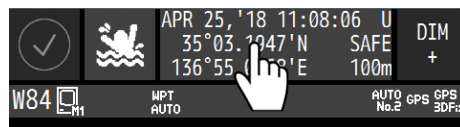

4.7.3 Registering marks

Register a cursor position as a mark.

Procedure

1. Display the PLOT1 or PLOT2 screen.

2.  → 



3. Display a cursor and move the cursor to the position to be marked.

4.  → 

4.7.4 Editing events/marks

Symbols, colours, and comments of events/marks can be edited.

Procedure

1.  →  → 
2. Tap an event or a mark to be edited.

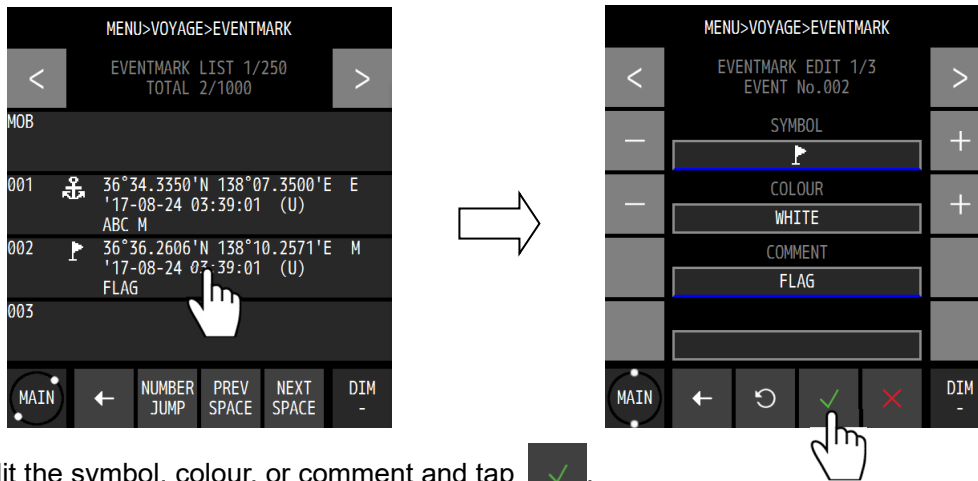

3. Edit the symbol, colour, or comment and tap .

4.7.5 Deleting events/marks

Events/marks can be deleted.



Procedure

1.  →  → 

The event/mark deletion submenu is outlined below.

- (1) EVENT MARK LIST: Select a deletion range from the event mark list.
- (2) ALL EVENT: Deletes all the events.
- (3) ALL MARK: Deletes all the marks.
- (4) ALL EVENT MARK: Deletes all the events/marks.

(1) EVENT MARK LIST

- a) When  is tapped, an event mark list is displayed.
- b) Tap a starting point and an ending point of the event marks to be deleted.
When deleting only one point, specify the same number for a starting point and an ending point.
- c) Confirm by using .

(2) ALL EVENT

a) Tap  .

(3) ALL MARK

a) Tap  .

(4) ALL EVENT MARK

a) Tap  .

2. When a deletion confirmation popup window is displayed, tap “YES”.

4.8 Plotting Screen

4.8.1 Operating the cursor

Procedure

1. Display the PLOT1 or PLOT2 screen.

2. **FUNC** → **CURSOR MODE**

3. Move the cursor by using the Up/Down/Left/Right arrow keys.

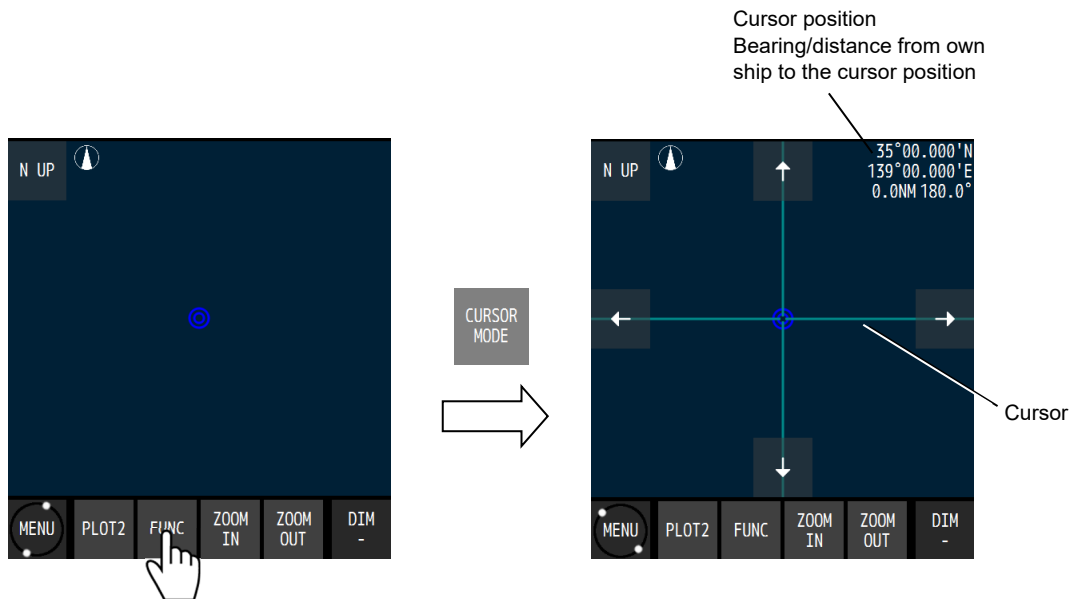

4.8.2 Changing the cursor size

A cursor size can be selected from LARGE/MIDDLE/SMALL.

Procedure

1. Display the PLOT1 or PLOT2 screen.

2. **FUNC** → **PLOT** → **CURSOR**

3. Select a size and confirm it with **✓**.

4.8.3 Moving a screen

The mouse can be used to move the tapped position to the centre of the screen.

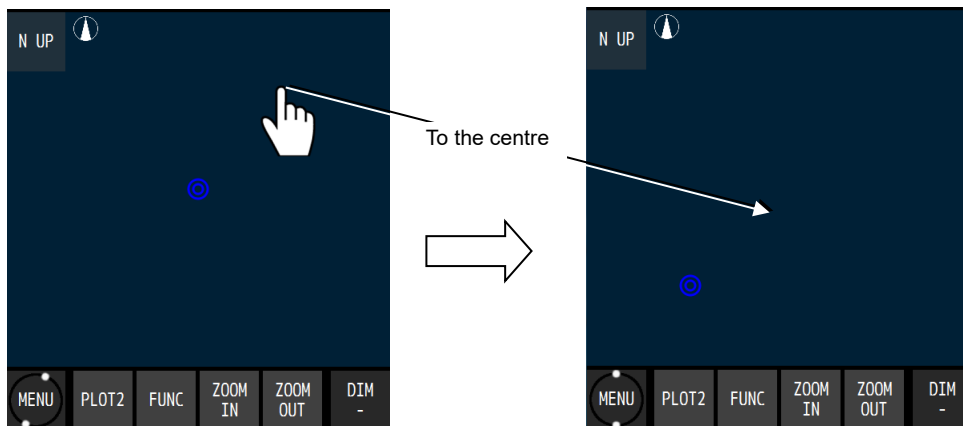

4.8.4 Moving own ship to the centre of the screen

When own ship is within the screen range, the own ship's position can be moved to the centre of the screen by tapping it.

When own ship is moved to the position outside of the screen range, disabling its display, tap "HOME" at the bottom left corner of the screen.

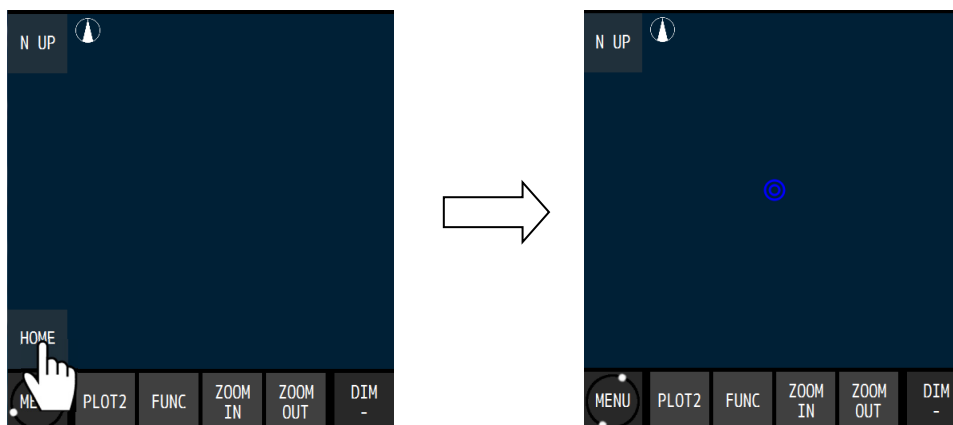

Memo

- When own ship is moved to the end of the screen, own ship is returned to the centre of the screen automatically.
- Own ship can also be moved to the centre of the screen by selecting "FUNC" → "HOME".

4.8.5 Screen Zoom In/Out

The plotting screen horizontal width can be set in the following.
0.2, 0.5, 1.0, 2.0, 5.0, 10.0, 20.0, 50.0, 100.0, 200.0, and 300.0 [NM]



ZOOM IN ———— | ———— ZOOM OUT

4.8.6 Changing North Up/Course Up

The screen mode can be changed to North Up, Course Up, or Relative North Up.

North Up: Own ship moves on the screen with North Up.

Course Up: The course of own ship is constantly set to the up position on the screen and the surrounding image moves.

Relative North Up: The top of the screen faces North and own ship's position is fixed and the surrounding image moves.

Whenever screen mode switching is tapped, the screen mode changes.

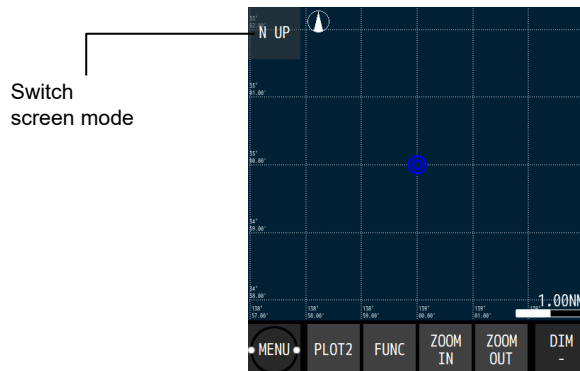

4.8.7 Displaying tracks



Tracks can be displayed.
A track storage interval can be set by time or distance.

Procedure

1. Display the PLOT1 or PLOT2 screen.

2.  →  → 



Item	Description
TRACK LINE	Select a track drawing line.
	 A track is drawn with dots.
	 A track is drawn with a line.
TRACK PERIOD	Set a track storage interval.
	TIME Up to 60 minutes can be set in second units by MIN/SEC.
	DIST Up to 99.99NM can be set in 0.01NM units.
	OFF Not stored

3. Set a storage interval and confirm with .

Memo

- When the scale of the plot screen is small and moving at high speed, the track may be plotted before the own ship's movement.

Deleting a track

1. Display the PLOT1 or PLOT2 screen.

2.  →  → 

When the following popup window is displayed, select "YES".

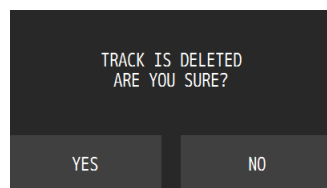

When "YES" is selected, the entire track is deleted. Partial deletion is not allowed.

4.8.8 Displaying an own ship vector and a distance circle

When a radius is specified, a circle is displayed positioning own ship at the centre. The range that can be set is from 0.1NM to 9.9NM.

By setting a time, a vector line up to the position where the ship reaches within the set time can be displayed. The time can be set within the range from 0.1 to 9.9 minutes.

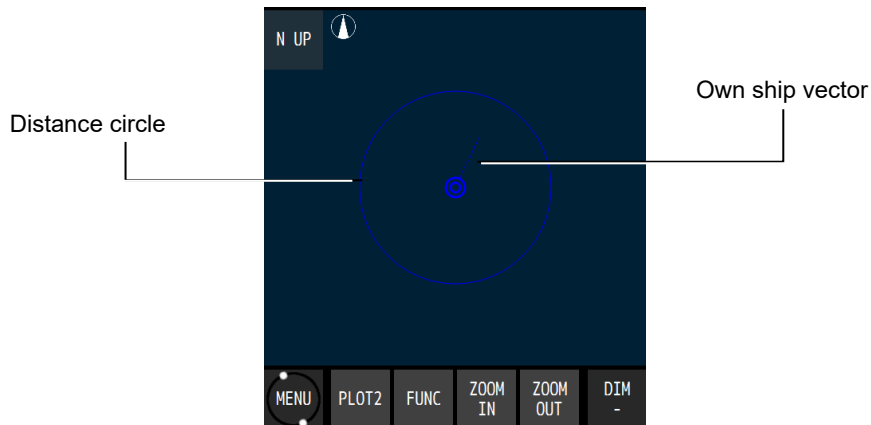

Procedure

1. Display the PLOT1 or PLOT2 screen.

2.  →  → 

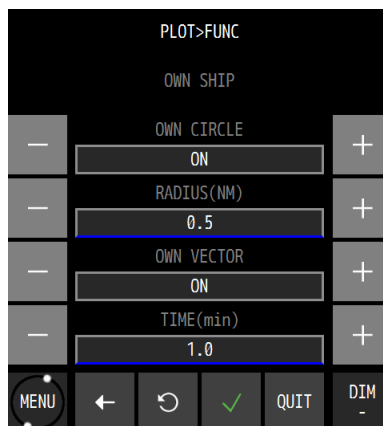

Item	Description
OWN CIRCLE	Set a distance circle from own ship.
RADIUS(NM)	Displayed when OWN CIRCLE is set to ON. Input a radius of the distance circle.
OWN VECTOR	Set an own ship's vector.
TIME(min)	Displayed when OWN VECTOR is set to ON. Displays the vector line up to the position that is reached within the time that is set.

3. Set a radius and a time and confirm the setting with .

4.8.9 Setting symbols to display/non-display

- Symbols that are displayed on a plotting screen can be set to non-display individually.
- Set the symbols that are not to be displayed to "OFF".
- Set the symbols that are to be displayed to "ON".
- The following symbols can be set to display/non-display.
Waypoint, waypoint number, mark, event, event/mark number, track, arrival circle, route width, scale bar, symbol information, cursor position information, grid line, grid latitude, and grid longitude

Procedure

1. Display the PLOT1 or PLOT2 screen.



3. Set the items to be displayed to "ON".

4. Confirm the setting with .

4.8.10 Displaying symbol information

When the cursor is moved to a waypoint, an event, or mark symbol, the contents of each symbol are displayed.

Procedure

1. Display the PLOT1 or PLOT2 screen.

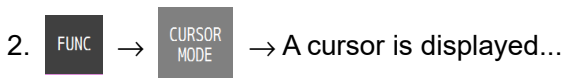

3. Move the cursor to symbol whose information is to be displayed.

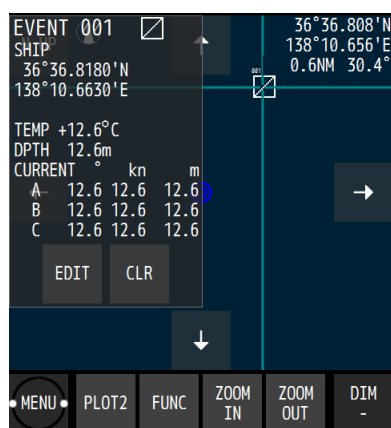

When a water temperature, a depth, and a current are received from external equipment, the water temperature, depth, and current at the storing of EVENT can be displayed. However, the external equipment must be connected.

To clear symbol information, move the cursor from the symbol.
To edit the information, tap "EDIT" and to clear the information, tap "CLR".

4.8.11 Changing a background colour

A background colour of a plotting screen can be changed.
The colors that can be set are DARK BLUE and WHITE.

Procedure

1. Display the PLOT1 or PLOT2 screen.

2.  → 

3. Select a background colour.

4. Confirm the selection with  .

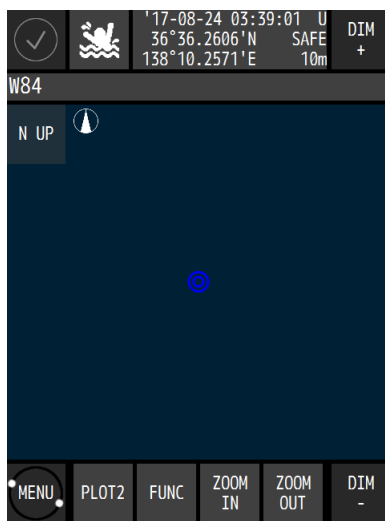

DARK BLUE

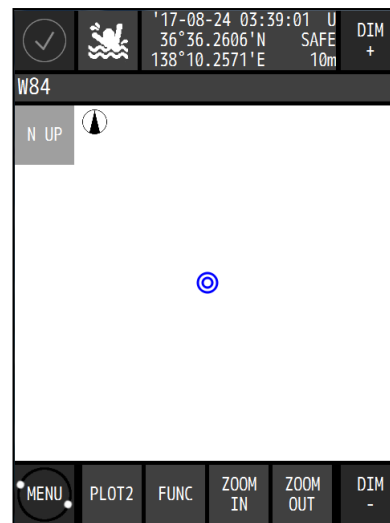

WHITE

4.9 Setting MOB

- MOB (Man-overboard) stores the position when a person or a material item fell overboard, by executing the MOB function. This function enables the ship to return to the position quickly.
- The MOB function is available on all the screens.
- When MOB is executed, a plotting screen is displayed automatically, the MOB mark is displayed, indicating the bearing and distance from the current position to the man-overboard position.

Procedure

1. Tap .

Countdown for 5 seconds starts at the bottom right corner of the screen. When  is tapped again within 5 seconds, the MOB function is cancelled.

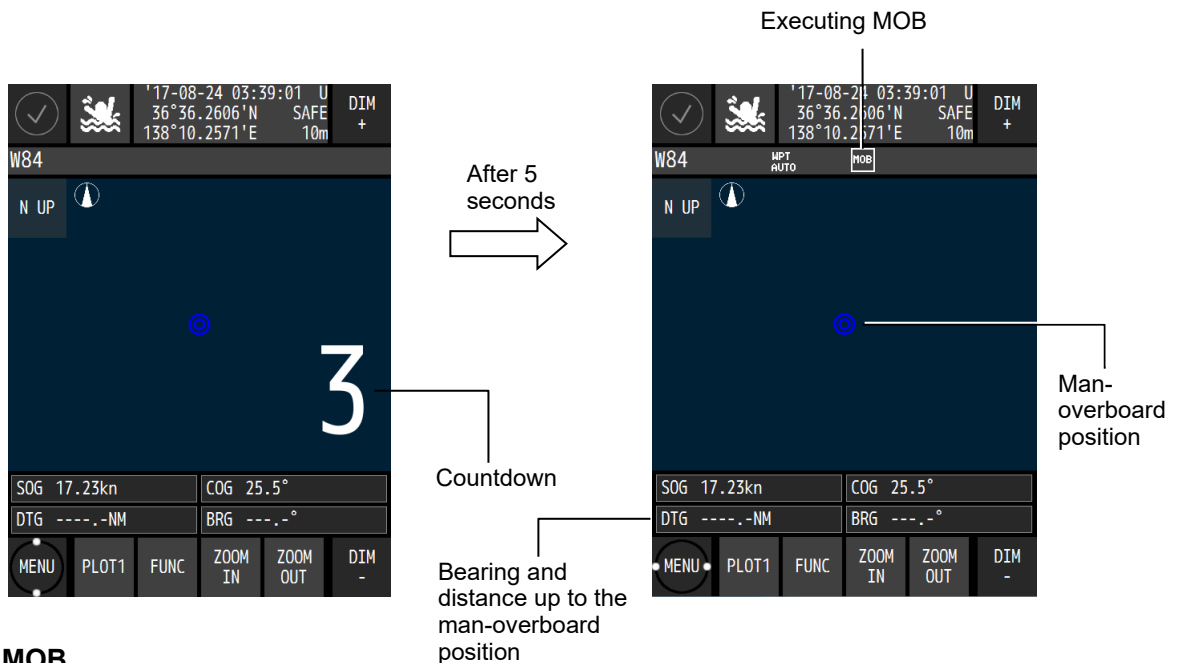

Ending MOB

1. Tap  again.
2. When the following popup window is displayed, select "YES".

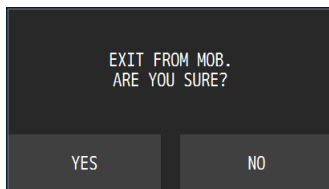

4.10 Setting Alerts



Fifteen types of alerts can be set. ON/OFF setting and buzzer ON/OFF can be set individually. The alerts that can be set are outlined below.

If sound is set to OFF, a buzzer sound is not emitted.

-Alerts for SOLAS ship-

- (1) SYSTEM: The alert is issued at the occurrence of non-position fixing.
- (2) HDOP: The alert is issued when the HDOP value exceeds the setting value.
- (3) SPEED: When the speed reaches within the setting range, the alert is issued.
- (4) TRIP: The alert is issued when the trip exceeds the setting value.
- (5) DGPS: The alert is issued when position fixing is changed from GPS to DGPS or from DGPS or GPS.
- (6) BUFFER: The alert is issued at the occurrence of a built-in buffer unit error.
- (7) POWER: The alert is issued at the occurrence of an external power supply error. External equipment is required for water temperature and water depth alerts.

-Alerts for non-SOLAS ship-

 CAUTION	
	Set the following alerts OFF on SOLAS ship. (Default setting is OFF)

- (8) ARRIVAL/ANCHOR: The alert is issued when the ship arrives at or crosses the track of the arrival circle radius.
Arrival and cross-track cannot be set concurrently.
- (9) XTD/BOUNDARY: The alert is issued when the ship crosses from or approached the route width.
Cross-track and approach cannot be set concurrently.
- (10) EARLY COURSE CHANGE:
The alert is issued when the time for reaching the wheel over point becomes below the setting value. Note1)
- (11) END OF TRACK: The alert is issued when the time for reaching the final waypoint is below the setting value. Note1)
- (12) ARRIVED AT WOL: The alert is issued when the ship reaches the wheel over point.
- (13) ACTUAL COURSE CHANGE:
The alert is issued 30 seconds before the ship reaches the wheel over point.
- (14) TEMP: The alert is issued when the water temperature comes within the setting range. Note2)
- (15) DEPTH: The alert is issued when the water depth comes within the setting range. Note2)

Note1) Only TCS route is supported.



Note2) External equipment is required for water temperature and water depth alerts.

4.10.1 Setting alert/buzzer sounds for SOLAS ship

To set an alert, a password is necessary. For the input method, refer to “4.2.11 Entering a password with CODE INPUT”.

Procedure

1. Enter a password by referencing “4.2.11. Entering a password with CODE INPUT”.
Password: 1650

2.  →  → An alert list is displayed.

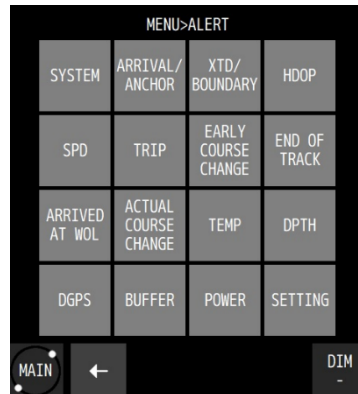

(1) Setting the SYSTEM alert

- a) Tap .

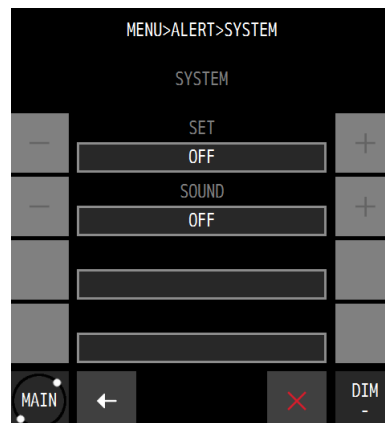

Item	Description
SET	Sets alert notification to ON/OFF. ON: Notifies the occurrence of an alert. OFF: Sets alert to OFF.
SOUND	Sets the buzzer sound upon the issuance of an alert to ON/OFF. ON: When an alert is issued, the alert is notified with a buzzer sound. OFF: Even if an alert is issued, a buzzer sound is not emitted.

(2) Setting the HDOP alert

a) Tap  .

Item	Description
SET	Sets alert notification to ON/OFF. THRESHOLD: The alert is issued when HDOP exceeded the threshold value. OFF: Sets the alert to OFF.
THRESHOLD	Sets a HDOP threshold value. This item is not displayed when SET is OFF.
SOUND	Sets the buzzer sound upon the issuance of an alert to ON/OFF. ON: When an alert is issued, the alert is notified with a buzzer sound. OFF: Even if an alert is issued, a buzzer sound is not emitted.

(3) Setting the SPEED alert

a) Tap  .

Item	Description
SET	Sets alert notification to ON/OFF. OVER: The alert is issued when the ship speed exceeds the set speed. UNDER: The alert is issued when the ship speed is below the set speed. IN RANGE: The alert is issued when the ship speed is within the set speed range. OUT RANGE: The alert is issued when the ship speed is outside of the set ship speed range. OFF: Sets the alert to OFF.
THRESHOLD	Set a ship speed threshold value when selecting "OVER"/"UNDER" in "SET".
THRESHOLD(OVER) THRESHOLD(UNDER)	Set an upper limit and a lower limit of the ship speed range when selecting "IN RANGE"/"OUT RANGE" in "SET".
SOUND	Sets the buzzer sound upon the issuance of an alert to ON/OFF. ON: When an alert is issued, the alert is notified with a buzzer sound. OFF: Even if an alert is issued, a buzzer sound is not emitted.

(4) Setting the TRIP alert

a) Tap  .

Item	Description
SET	Sets alert notification to ON/OFF. THRESHOLD: The alert is issued when the trip exceeds the set trip. OFF: Sets the alert to OFF.
THRESHOLD	Set a threshold value of the trip. This item is not displayed when SET is OFF.
SOUND	Sets the buzzer sound upon the issuance of an alert to ON/OFF. ON: When an alert is issued, the alert is notified with a buzzer sound. OFF: Even if an alert is issued, a buzzer sound is not emitted.

(5) Setting the DGPS alert

a) Tap  .

Item	Description
SET	Sets alert notification to ON/OFF. GPS→DGPS: The alert is issued when the positioning system is changed from GPS to DGPS. DGPS→GPS: The alert is issued when the positioning system is changed from DGPS to GPS. GPS⇔DGPS: The alert is issued when the positioning system is changed from GPS to DGPS or DGPS to GPS. OFF: Sets the alert to OFF.
SOUND	Sets the buzzer sound upon the issuance of an alert to ON/OFF. ON: When an alert is issued, the alert is notified with a buzzer sound. OFF: Even if an alert is issued, a buzzer sound is not emitted.

The DGPS alert is not notified to external equipment.

(6) Setting the BUFFER alert

a) Tap  .

Item	Description
SET	Sets alert notification to ON/OFF. ON: Notifies the alert. OFF: Sets the alert to OFF.
SOUND	Sets the buzzer sound upon the issuance of an alert to ON/OFF. ON: When an alert is issued, the alert is notified with a buzzer sound. OFF: Even if an alert is issued, a buzzer sound is not emitted.

(7) Setting the POWER alert

a) Tap  .

Item	Description
SET	Sets alert notification to ON/OFF. ON: Notifies the alert. OFF: Sets the alert to OFF.
SOUND	Sets the buzzer sound upon the issuance of an alert to ON/OFF. ON: When an alert is issued, the alert is notified with a buzzer sound. OFF: Even if an alert is issued, a buzzer sound is not emitted.

3. Confirm the settings with 

4.10.2 Setting alert/buzzer sounds for non-SOLAS ship

CAUTION





Set the following alerts OFF on SOLAS ship. (Default setting is OFF)

To set an alert, a password is necessary. For the input method, refer to “4.2.11 Entering a password with CODE INPUT”.

Procedure

1. Enter a password by referencing “4.2.11. Entering a password with CODE INPUT”.
Password: 1650

2.  →  → An alert list is displayed.

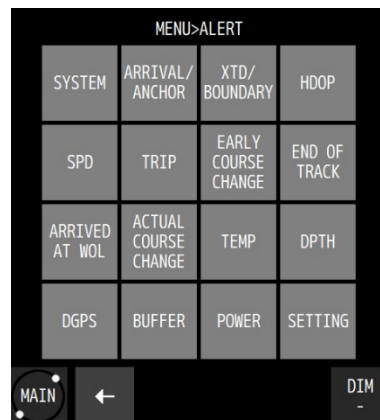

(8) Setting ARRIVAL/ANCHOR alerts

The alert is issued when the ship arrives at or crossed the arrival circle radius that was set in the route. If the arrival circle radius is not set in the route, the alert is issued when the ship reaches the arrival circle radius that is set as the route initial value.

Arrival and cross-track cannot be set concurrently.

- a) Tap .

Item	Description
SET	Sets alert notification to ON/OFF. ARRIVAL: Notifies the waypoint arrival alert. ANCHOR: Notifies the waypoint cross-track alert. OFF: Sets the alert to OFF.
SOUND	Sets the buzzer sound upon the issuance of an alert to ON/OFF. ON: When an alert is issued, the alert is notified with a buzzer sound. OFF: Even if an alert is issued, a buzzer sound is not emitted.

(9) Setting XTD/BOUNDARY alerts

The alert is issued when the ship cross-tracks from or approaches the route width that was set in the route. When the route width is not set in the route, an alert is issued when the ship cross-tracks from or enters in the route width that is set as the initial value in the route. Cross-track and approach cannot be set concurrently.

a) Tap 

Item	Description
SET	Sets alert notification to ON/OFF. XTD: Notifies a cross-track distance alert. BOUNDARY: Notifies a route approach alert. OFF: Sets the alert to OFF.
SOUND	Sets the buzzer sound upon the issuance of an alert to ON/OFF. ON: When an alert is issued, the alert is notified with a buzzer sound. OFF: Even if an alert is issued, a buzzer sound is not emitted.

(10) Setting the EARLY COURSE CHANGE alert

a) Tap 

Item	Description
SET	Sets alert notification to ON/OFF. THRESHOLD: The alert is issued when the time to reach the Wheel Over Point is less than the threshold value. OFF: Sets the alert to OFF.
THRESHOLD	Set a threshold value of EARLY COURSE CHANGE. A value from 3 minutes to 6 minutes can be set. This item is not displayed when SET is OFF.
SOUND	Sets the buzzer sound upon the issuance of an alert to ON/OFF. ON: When an alert is issued, the alert is notified with a buzzer sound. OFF: Even if an alert is issued, a buzzer sound is not emitted.

(11) Setting the END OF TRACK alert

a) Tap 

Item	Description
SET	Sets alert notification to ON/OFF. THRESHOLD: The alert is issued when the time to reach the final waypoint is less than the threshold value. OFF: Sets the alert to OFF.
THRESHOLD	Set a threshold value of END OF TRACK. A value from 3 minutes to 6 minutes can be set. This item is not displayed when SET is OFF.
SOUND	Sets the buzzer sound upon the issuance of an alert to ON/OFF. ON: When an alert is issued, the alert is notified with a buzzer sound. OFF: Even if an alert is issued, a buzzer sound is not emitted.

(12) Setting the ARRIVED AT WOL alert

a) Tap 

Item	Description
SET	Sets alert notification to ON/OFF. ON: Notifies the alert. OFF: Sets the alert to OFF.
SOUND	Sets the buzzer sound upon the issuance of an alert to ON/OFF. ON: When an alert is issued, the alert is notified with a buzzer sound. OFF: Even if an alert is issued, a buzzer sound is not emitted.

(13) Setting the ACTUAL COURSE CHANGE alert

a) Tap 

Item	Description
SET	Sets alert notification to ON/OFF. ON: Notifies the alert. OFF: Sets the alert to OFF.
SOUND	Sets the buzzer sound upon the issuance of an alert to ON/OFF. ON: When an alert is issued, the alert is notified with a buzzer sound. OFF: Even if an alert is issued, a buzzer sound is not emitted.

(14) Setting the water temperature alert

a) Tap 

Item	Description
SET	Sets alert notification to ON/OFF. OVER: The alert is issued when the water temperature exceeds the set temperature. UNDER: The alert is issued when the water temperature is below the set temperature. IN RANGE: The alert is issued when the water temperature is within the set temperature range. OUT RANGE: The alert is issued when the water temperature is outside of the set water temperature range. OFF: Sets the alert to OFF.
THRESHOLD THRESHOLD(OVER) THRESHOLD(UNDER)	Set a water temperature threshold value when selecting "OVER"/"UNDER" in "SET". Set an upper limit and a lower limit of the water temperature range when selecting "IN RANGE"/"OUT RANGE" in "SET".
SOUND	Sets the buzzer sound upon the issuance of an alert to ON/OFF. ON: When an alert is issued, the alert is notified with a buzzer sound. OFF: Even if an alert is issued, a buzzer sound is not emitted.

The water temperature alert requires external equipment.

(15) Setting the water depth alert

a) Tap 

Item	Description
SET	Sets alert notification to ON/OFF. OVER: The alert is issued when the water depth exceeds the set depth. UNDER: The alert is issued when the water depth is below the set depth. IN RANGE: The alert is issued when the water depth is within the set water depth range. OUT RANGE: The alert is issued when the water depth is outside of the set water depth range. OFF: Sets the alert to OFF.
THRESHOLD THRESHOLD(OVER) THRESHOLD(UNDER)	Set a water depth threshold value when selecting "OVER"/"UNDER" in "SET". Set an upper limit and a lower limit of the water depth range when selecting "IN RANGE"/"OUT RANGE" in "SET".
SOUND	Sets the buzzer sound upon the issuance of an alert to ON/OFF. ON: When an alert is issued, the alert is notified with a buzzer sound. OFF: Even if an alert is issued, a buzzer sound is not emitted.

The water depth alert requires external equipment.

4.10.3 Alert setting

The available settings are as follows.

- ALARM ESCALATION: Select whether the "No positioning" warning will escalate to an alarm.
- HEADER ALERT: Select whether to display the aggregation, grouping in the alert list.
- TEST MODE: Select whether to return the ALF of all alerts for "Q" of ACN for wildcard.

To set an alert, a password is necessary. For the input method, refer to "4.2.11 Entering a password with CODE INPUT".

(1) ALARM ESCALATION

Select whether the "No positioning" warning will escalate to an alarm.

Procedure

1. Enter a password by referencing "4.2.11. Entering a password with CODE INPUT".
Password: 1650



Item	Description
POSITION	Sets alarm escalation to ON/OFF. ON: Enable the escalation. OFF: Disable the escalation.
HEADING	JLR-8600/JLR-8600-D does not support.
TIME(s)	Set the time until escalation.

(2) HEADER ALERT

Select whether to display the aggregation, grouping in the alert list.

Procedure

1. Enter a password by referencing “4.2.11. Entering a password with CODE INPUT”.
Password: 1650

2.  →  →  → 

Item	Description
GUROPING	Displays common alerts as a group in the alert list. ON: Enable the grouping. OFF: Disable the grouping.
AGGREGATION	Displays common alert ID, category, and priority alerts as an aggregation in the alert list. ON: Enable the aggregation. OFF: Disable the aggregation.

(3) TEST MODE

Select whether to return the ALF of all alerts for “Q” of ACN for wildcard.

Procedure

1. Enter a password by referencing “4.2.11. Entering a password with CODE INPUT”.
Password: 1650

2.  →  →  → 

Item	Description
TEST MODE	Select whether to return the ALF of all alerts for “Q” of ACN for wildcard. ON: Returns ALF of all alerts (include normal condition). OFF: Returns ALF other than normal condition.

4.11 Alert List









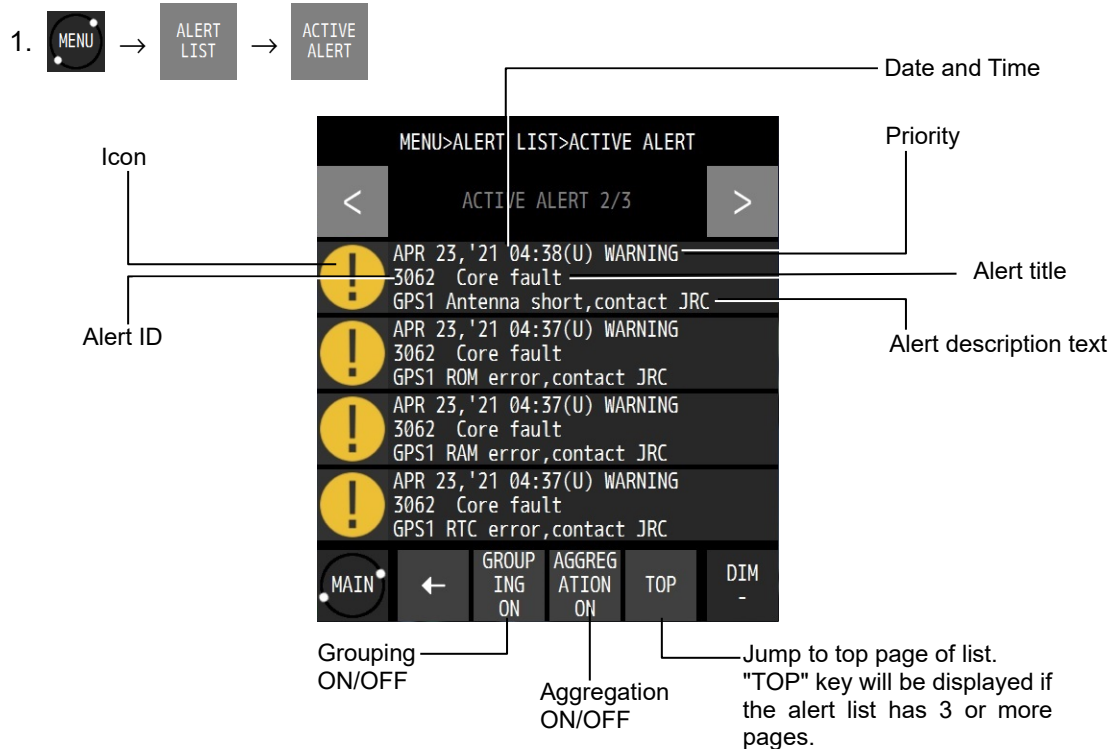

The alerts that have occurred so far and the alert that is occurring, and the alerts that occurred in LAN can be displayed.

4.11.1 Displaying the alert that is occurring

The alert that is occurring can be displayed. They are displayed in order of priority. After the alert is resolved, the alert is deleted from the alert list.

Procedure



Priority	Icon	Status	Icon	Status
Alarm		Active-Unacknowledged		Active-Silenced
		Active-Acknowledged		Rectified- Unacknowledged
		Responsibility transferred	-	-
Warning		Active-Unacknowledged		Active-Silenced
		Active-Acknowledged		Rectified- Unacknowledged
		Responsibility transferred	-	-
Caution		Active	-	-

(1) Grouping

Displays common alerts as a group in the alert list.
Member of grouping can be displayed.

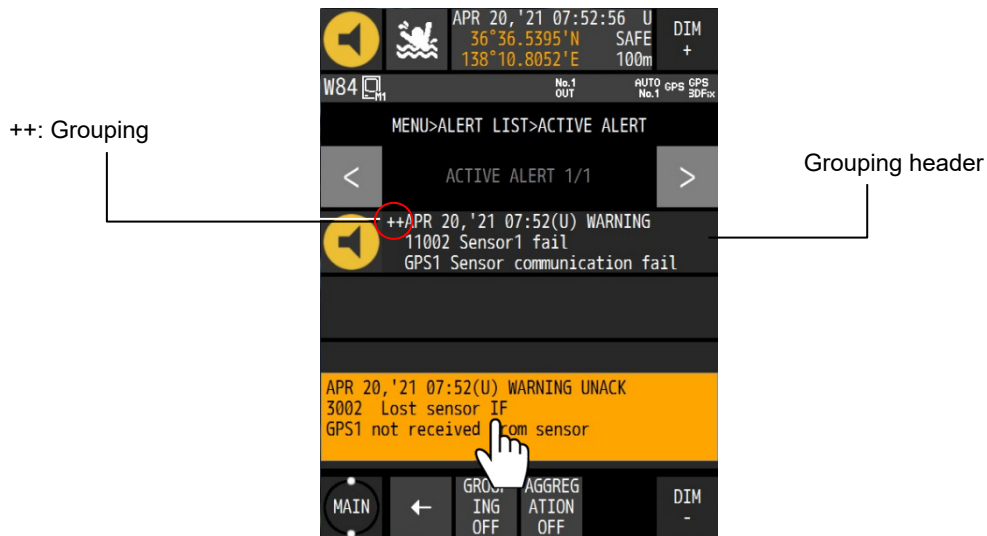

Tap the pop-up (alert description) of all alert, and acknowledge.

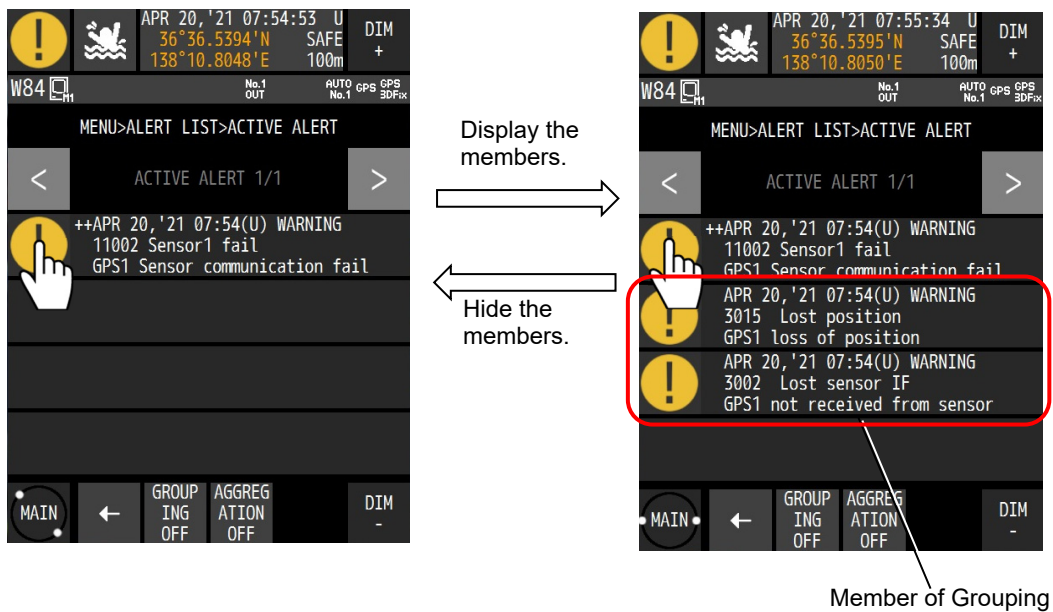

Tap the icon of grouping header, the members of grouping are displayed.
Tap again, the members of grouping are hidden.

(2) Aggregation

Displays common alert ID, category, and priority alerts as an aggregation in the alert list. Member of aggregation can be displayed.



Tap the pop-up (alert description) of all alert, and acknowledge.

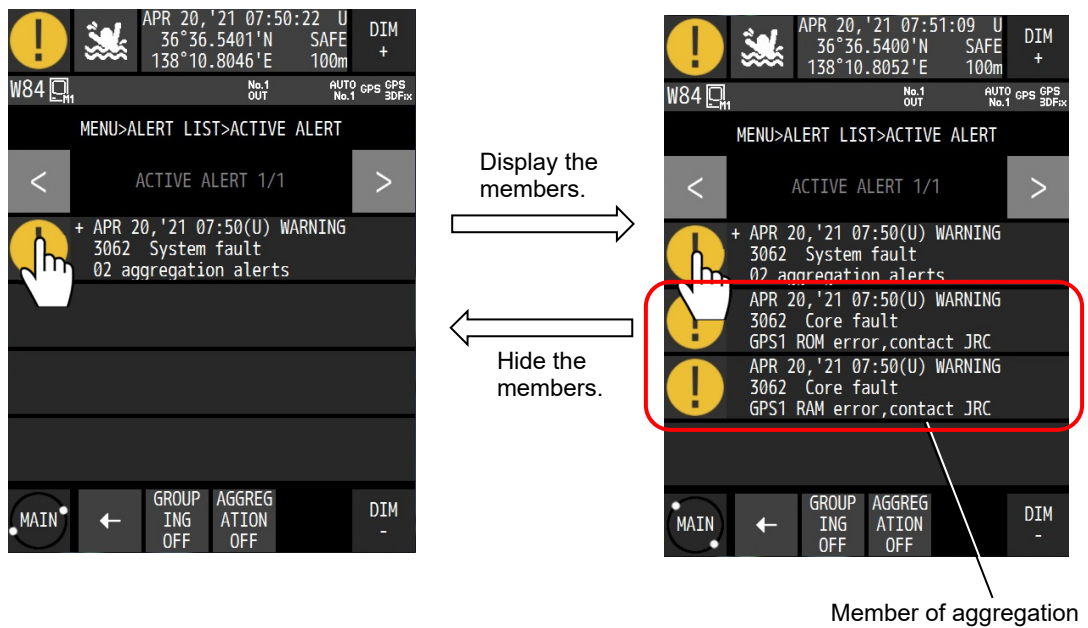

Tap the icon of aggregation header, the members of aggregation are displayed. Tap again, the members of aggregation are hidden.

4.11.2 Displaying alert history

The alerts that have occurred so far can be displayed.

Up to 100 alerts can be displayed. If the number of alerts exceeds 100, the existing alerts are overwritten from the oldest one.

Procedure

1.  →  → 

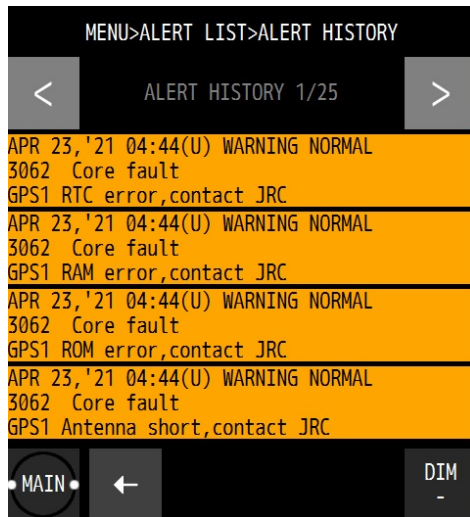

Rad :Alarm
Orange :Warning
Yellow :Caution

UNACK :Unacknowledged
ACKED :Acknowledged
RESPONSIBILITY :Responsibility transferred
RECTIFIED :Rectified
NORMAL :Normal

4.11.3 Displaying the alerts that occurred in LAN

The number of errors that occurred in LAN1/LAN2 is displayed.

The error count is cleared when the power is turned off.

Procedure

1.  → 

(1) Displaying the error count of LAN1

- a) Tap .

(2) Displays the error count of LAN2

- a) Tap .

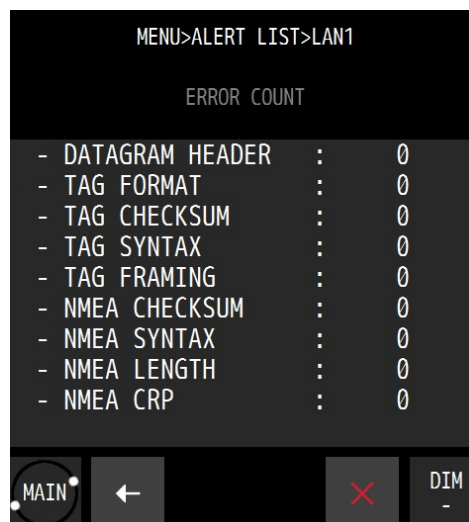

Clearing an alert

- 1. Enter a password by referencing "4.2.11 Entering a password in CODE INPUT".
Password: 1650

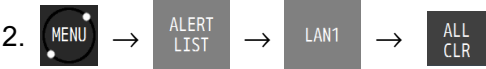

To clear the LAN2 alert list, select  .

4.12 Initial Settings of GNSS/Beacon/SBAS

Set the GNSS sensor.

JLR-4350 supports multi-GNSS.

The available GNSS system combinations are as follows.

- (1) GPS mode
 - a) GPS
- (2) Multi-GNSS mode
 - a) GPS+QZSS
 - b) GPS+GLONASS
 - c) GPS+QZSS
 - d) GPS+QZSS+GLONASS
 - e) GPS+QZSS+BeiDou

Even in multi-GNSS mode also, GLONASS and BeiDou cannot be used concurrently.

DGLONASS and DBeiDou are not supported. When using DGPS by SBAS/beacon, use it in GPS mode.

In multi-GNSS mode also, position fixing is performed without using the systems that cannot be received by the satellites.

Memo

GPS: Global Positioning System. Positioning system that is operated by the U.S.A.

QZSS: Quasi-Zenith Satellite System (Michibiki). Positioning system that is operated by Japan.

GLONASS: Global Navigation Satellite System. Positioning system that is operated by Russia.

BeiDou: Positioning system that is operated by China.

In JLR-4350, only QZSS No.1 can be used. Correction data cannot be received from QZSS.

4.12.1 Setting a positioning system

Select a GNSS system to be used.

In the processor with two sensors installed, the sensors must be set individually.

In this example, sensor 1 is connected. The same procedure is applied for setting sensor 2.

Procedure

1. Enter a password by referencing "4.2.11. Entering a password with CODE INPUT".

Password: 1650

2.  →  →  → 

GPS MODE	Description
GPS	Operates in GPS mode. Only GPS is used. To perform DGPS by SBAS/beacon, set "GPS".
GPS+QZSS	Operates in multi-GNSS mode. GPS and QZSS are used concurrently.
GPS+GLONASS	Operates in multi-GNSS mode. GPS and GLONASS are used concurrently.
GPS+BDS	Operates in multi-GNSS mode. GPS and BeiDou are used concurrently.
GPS+QZSS+GLONASS	Operates in multi-GNSS mode. GPS, QZSS, and GLONASS are used concurrently.
GPS+QZSS+BDS	Operates in multi-GNSS mode. GPS, QZSS, and BeiDou are used concurrently.

Memo

When a positioning system is changed, non-positioning is set temporarily. Although the condition is rectified immediately, note that the information to the external equipment that is connected is also set to non-positioning.

4.12.2 Setting a position fixing mode

A position fixing mode can be selected from Automatic, 3-dimensional position fixing, and 2-dimensional position fixing.

For a processor with two sensors connected, the sensors must be set individually. In this example, sensor 1 is connected. The same procedure is applied for setting sensor 2 also.

Procedure

1. Enter a password by referencing "4.2.11. Entering a password with CODE INPUT".
Password: 1650

2. 

FIX MODE	Description
AUTO	Switches to the optimum position fixing mode automatically from the 3-dimensional position fixing or 2-dimensional position fixing mode.
2D	Positions in 2-dimensional position fixing mode.
3D	Positions in 3-dimensional position fixing mode.

4.12.3 Setting an elevation mask

Set an elevation mask.

When an elevation mask is set, the satellites of the elevations lower than the set value are not used for position fixing.

For a processor with two sensors connected, the sensors must be set individually. In this example, sensor 1 is connected. The same procedure is applied for setting sensor 2 also.

Procedure

1. Enter a password by referencing "4.2.11. Entering a password with CODE INPUT".
Password: 1650

2. 

ELV MASK	Description
SAT ELV MASK	Set an elevation mask. Set an elevation within the range from 5 to 89 degrees.

4.12.4 Setting HDOP

Set a HDOP limit of the sensor. When HDOP exceeded the set value, the system is set to a non-position fixing mode.

For a processor with two sensors connected, the sensors must be set individually. In this example, sensor 1 is connected. The same procedure is applied for setting sensor 2 also.

Procedure

1. Enter a password by referencing "4.2.11. Entering a password with CODE INPUT".
Password: 1650



HDOP	Description
HDOP	Set the threshold value of HDOP. Select 4, 10, or 20.

4.12.5 Setting position, speed, and course smoothing

Smoothing can be applied to the position that is fixed, speed, and course for the smooth changes. If the smoothing value is increased, processing becomes smoother, however, the trackability deteriorates. If the smoothing value is reduced, changes increase, however, the trackability improves. Set the optimum value according to the purpose.

JLR-4350 supports individual smoothing of position, speed, and course.

For a processor with two sensors connected, the sensors must be set individually. In this example, sensor 1 is connected. The same procedure is applied for setting sensor 2 also.

Procedure

1. Enter a password by referencing "4.2.11. Entering a password with CODE INPUT".
Password: 1650



SMOOTH	Description
POSN SMOOTHING	Applies smoothing to position changes. A value between 0 second and 99 seconds can be set.
SPEED SMOOTHING	Applies smoothing to speed changes. A value between 0 second and 99 seconds can be set.
COURSE SMOOTHING	Applies smoothing to course changes. A value between 0 second and 99 seconds can be set.

Memo

When the smoothing value is increased, the trackability of quick turning and sudden speed change deteriorates.
Normally, the setting of 10 seconds or less is recommended. The default value is 10 seconds.
When setting a higher value, adequate caution is necessary.

4.12.6 Setting RAIM

RAIM (Receiver Autonomous Integrity Monitoring) checks the accuracy of GPS with the accuracy level and displays the status.

When the reliability of the error that was obtained is 95% or higher, the state is displayed as "SAFE" or "UNSAFE". When the reliability is 95% or lower, "CAUTION" is displayed.

SAFE: The position error is within the set accuracy level.

CAUTION: Cannot calculate with the set accuracy level.

UNSAFE: The position error exceeded the set accuracy level.

An accuracy level of RAIM can be set.

An accuracy level can be selected from OFF, 10m, 30m, 50m, and 100m.

To perform GPS independent position fixing, set 30m or more. If GPS independent position fixing is performed by setting 10m, the reliability 95% is not satisfied and this may result in "CAUTION".

When OFF is set, "RAIM OFF" is displayed on the screen, and the RAIM function stops. Therefore, when RAIM is OFF, the system cannot perform calculation as to whether the reliability is within the accuracy level.

For a processor with two sensors connected, the sensors must be set individually.

In this example, sensor 1 is connected. The same procedure is applied for setting sensor 2 also.

Procedure

1. Enter a password by referencing "4.2.11. Entering a password with CODE INPUT".

Password: 1650

2. 

RAIM	Description
RAIM ACCURACY LEVEL	Set an accuracy level of RAIM. Select from OFF, 100m, 50m, 30m, and 10m.

Memo

RAIM

RAIM is the abbreviation of Receiver Autonomous Integrity Monitoring and checks, in the receiver, if the position accuracy that was fixed by GNSS is within the necessary accuracy.

4.12.7 Setting a geodetic system

A geodetic system of the position that was fixed can be set.

For the geodetic systems that can be set, refer to "Appendix 1 List of Geodetic System".

For a processor with two sensors connected, the sensors must be set individually.

In this example, sensor 1 connected. The same procedure is applied for setting sensor 2 also.

Procedure

1. Enter a password by referencing "4.2.11. Entering a password with CODE INPUT".

Password: 1650

2. 

DATUM	Description
DATUM	Set a geodetic system. For the geodetic systems that can be set, refer to "Appendix 1 List of Geodetic System".

4.12.8 Initialising sensors

Initialise sensors.

Set a general position and current date and time (UTC) of the sensor.

For a processor with two sensors connected, the sensors must be set individually.

In this example, sensor 1 is connected. The same procedure is applied for setting sensor 2 also.

Procedure

1. Enter a password by referencing "4.2.11. Entering a password with CODE INPUT".
Password: 1650



INIT	Description
QUADRANT	Select North latitude/South latitude/East latitude/West latitude of the sensor position.
LAT	Enter a general position (latitude) of the sensor.
LON	Enter a general position (longitude) of the sensor.
ANT HEIGHT	Enter a general position (height) of the sensor. For 2-dimensional position fixing, this height is used.
YEAR	Enter the current year (UTC).
MONTH	Enter the current month (UTC).
DAY	Enter the current day (UTC).
HOURL	Enter the current hour (UTC).
MINUTE	Enter the current minute (UTC).

4.12.9 Setting a DGPS correction mode

A DGPS correction mode can be selected.

To perform DGPS correction, set the positioning system to "GPS".

In multi-GNSS mode, DGPS positioning cannot be performed.

If a correction mode is set in multi-GNSS mode, the positioning system is automatically set to "GPS".

JLR-4350 does not support DGLONASS and DBeiDou. Correction data of QZSS cannot be received.

For a processor with two sensors connected, the sensors must be set individually.

In this example, sensor 1 is connected. The same procedure is applied for setting sensor 2 also.

Procedure

1. Enter a password by referencing "4.2.11. Entering a password with CODE INPUT".
Password: 1650

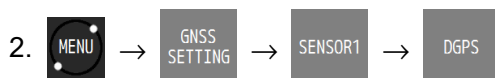

DGPS	Description
AUTO	Selects beacon or SBAS automatically. When both a beacon and SBAS can be received, priority is given to a beacon. When neither a beacon nor SBAS can be received, GPS positioning is performed.
BEACON	Performs DGPS by using a beacon. When a beacon cannot be received, GPS positioning is performed.
SBAS	Performs DGPS by SBAS. When SBAS cannot be received, GPS positioning is performed.
OFF	DGPS positioning is not performed.

Memo

- When a correction mode is set in multi-GNSS mode, the positioning system is automatically switched to “GPS”. In this case, the system is set to non-positioning temporarily.
- When setting SBAS, it takes time to SBAS positioning because it searches SABS satellites.

4.12.10 Setting a beacon

Set DGPS by using a beacon.

JLR-8600 does not support the beacon setting. To perform a DGPS fixing by using a beacon, an external beacon receiver is necessary.

For a processor with two sensors connected, the sensors must be set individually.

In this example, sensor 1 is connected. The same procedure is applied for setting sensor 2 also.

Procedure

1. Enter a password by referencing "4.2.11. Entering a password with CODE INPUT".

Password: 1650

2.  →  →  → 

3. Set a beacon station selection method.

The selection method is outlined below.

- (1) **AUTO**: Selects an optimum beacon station from the GPS position.
- (2) **MANUAL**: Set a frequency and a baud rate of the beacon station manually.
- (3) **SEMI AUTO**: Automatically selects an optimum beacon station from up to three stations that are selected from the adjacent stations at random. JLR-8600 does not support this function.
- (4) **MONITOR**: JLR-8600 does not support this function.

(1) AUTO

- a) Tap  .

(2) MANUAL

- a) Tap  .

MANUAL	Description
FREQUENCY	Set a frequency.
BITRATE	Set a bit rate.

- b) Tap  to confirm the setting.

4.12.11 Setting SBAS

Set DGPS by SBAS.

For a processor with two sensors connected, the sensors must be set individually. In this example, sensor 1 is connected. The same procedure is applied for setting sensor 2 also.

Procedure

1. Enter a password by referencing "4.2.11. Entering a password with CODE INPUT".
Password: 1650

2. 

SBAS	Description
SAT SEARCH	AUTO: Selects an optimum SBAS satellite. MANUAL: Set a SBAS satellite number.
SBAS TYPE 0	When SAT SEARCH is set to MANUAL, set a SBAS satellite number. Set the use of TYPE 0 data (test data) to ON/OFF. Normally, set to "OFF".
RANGING	Set whether the SBAS satellite is used for positioning in the same way as the GPS satellite. Since JLR-4350 is not equipped with the ranging function, set to "OFF".

4.12.12 Displaying a beacon station list

JLR-8600 does not support this function.

Display a list of all the beacon stations.
Up to 1024 stations can be displayed.

For a processor with two sensors connected, the sensors must be set individually. In this example, sensor 1 is connected. The same procedure is applied for setting sensor 2 also.

4.13 Configuring a System

4.13.1 Setting time difference/date display

A time difference between UTC and the local time can be set.
 In the case of a Japan time, enter +-9:00 since the time difference is +9 hours.
 When a time difference is set, the local time ("L") is displayed.
 A date/time display format can be selected.

Procedure

1. Enter a password by referencing "4.2.11. Entering a password with CODE INPUT".
 Password: 1650

2.  →  → 

Item	Description
TIME DIFF	Set a time difference.
DATE DISP	Select a date display format from the following: 'YY-MM-DD / DD MMM, 'YY / MMM DD, 'YY.
TIME DISP	24hr: Displays a time from 00:00 to 23:59. 12hr: Displays a time from AM/PM 00:00 to 11:59.

3. Confirm the setting with .

4.13.2 Setting units

Set units of ship speed, distance, height, depth, and temperature.

Procedure

1. Enter a password by referencing "4.2.11. Entering a password with CODE INPUT".
 Password: 1650

2.  →  → 

Item	Description
DIST/SPEED	Select a unit of a distance and a ship speed from NM, kn / km, km/h / mi, mi/h.
HIGHT/DPTH	Select a unit of a height and a depth from m / ft / fm.
SETTING METHOD	Case where fm is selected MANUAL: A converted value between fm and m can be set. DEFAULT: A converted value between fm and m is 1.8288m.
CONVERTED VALUE	Set a converted value between fm and m.
TEMP	Select a water temperature from Celsius/Fahrenheit.

3. Confirm the selecting with .

4.13.3 Setting magnetic correction

Magnetic correction can be applied to the route that was obtained from GPS.

Procedure

1. Enter a password by referencing "4.2.11. Entering a password with CODE INPUT".
Password: 1650

2.  →  → 

MAG CORR	Description
AUTO	Performs correction automatically by calculating the correction value from the GPS position.
MANUAL	Performs correction with the correction value that was input. EAST/WEST: Select East longitude or West longitude. CORRECTION VALUE: Enter a correction value.
OFF	Does not perform correction.

3. Confirm the setting with .

4.13.4 Setting LORAN A/C





A position can be displayed or set with a time difference.

When LORAN A/C is set, all the position information is displayed in time difference.

Procedure

1. Enter a password by referencing "4.2.11 Entering a password in CODE INPUT".
Password: 1650

2.  →  → 

LORAN	Description
LORAN A	  : Moves to the LORAN A setting screen.
LORAN C	  : Moves to the LORAN C setting screen.
OFF	Displays in the latitude/longitude.

3. Enter each setting value.

4. Tap  to confirm the setting.

Memo

- LORAN A stations that can be set
1S1, 1S2, 1S3, 1S4, 1S6, 1L0, 1L1, 1L4, 1L5, 2S0, 2S1, 2S2, 2S3, 2S4, 2S5, 2S6, 2S7, 2H4, 2H5, 2H6
- LORAN C chains that can be set
4990, 5930, 5970, 5980, 5990, 6730, 6731, 6780, 7001, 7030, 7170, 7270, 7430, 7499, 7930, 7950, 7960, 7970, 7980, 7990, 8000, 8290, 8390, 8830, 8930, 8970, 8990, 9007, 9610, 9930, 9940, 9960, 9970, 9980, 9990

4.13.5 Selecting a sensor

Specify which sensor will be displayed when two sensors are connected to one processor.

Procedure

1. Enter a password by referencing "4.2.11 Entering a password in CODE INPUT".
Password: 1650

2.  →  → Select a sensor.

Item	Description
AUTO	Preferentially displays the sensor of sensor port 1.
SENSOR1	Displays the sensor connected to sensor port 1.
SENSOR2	Displays the sensor connected to sensor port 2.

CAUTION

- Normally "SENSOR SELECT" set to "AUTO".
Even if it set to "SENSOR1" or "SENSOR2", it returns to "AUTO" when the power is turned OFF.

4.14 Printing

When a network printer is connected, data is transmitted to the printer.

Procedure

1.  → 

Whenever  is tapped, printing data is transmitted.

Memo

To perform printing, a port must be set in the installation.
To perform interval printing, a port must be set in the installation.

4.15 Setting a Language

Select a display language.
Japanese and English can be selected as the language.

Procedure

1. Enter a password by referencing "4.2.11. Entering a password with CODE INPUT".
Password: 1650



2.  → 

4.16 Verifying Versions

Display version information of each unit.

Procedure

1.  → 

2. Change the unit by using   .

4.17 Displaying a total trip distance



A total trip distance can be displayed on navigation aid screen 2.

A trip distance can be calculated on the total trip distance display screen.

Total trip distance calculation continues even if the trip distance measurement is interrupted.

4.17.1 Starting/stopping measurement of a trip distance

Procedure

1. Display navigation aid information screen 2 by selecting  and tapping  several times.

2.  → 

Trip distance calculation starts.

Tap the following to interrupt the calculation.

3.  → 

Trip distance calculation is interrupted.



By tapping  again, trip distance calculation can be restarted.

4.17.2 Resetting a trip distance

A trip distance can be reset even during the calculation of a total trip distance.

Even if a trip distance is reset, the total trip distance is not reset.

Procedure

1. Display navigation aid information screen 2 by selecting  and tapping  several times.

2.  → 



The trip distance is reset.

4.17.3 Resetting a total trip distance

A total trip distance can be reset.

Once a total trip distance is reset, it is reset to zero. The trip distance is also reset to zero.

Procedure

1. Display navigation aid information screen 2 by selecting  and tapping  several times.

2.  → 



The total trip distance is reset.

4.18 Measuring a trip distance

A trip distance can be measured on navigation aid screen 3.
Two trip distances can be measured simultaneously in this equipment.

4.18.1 Starting/stopping measurement

Procedure



1. Display navigation aid information 3 screen by selecting  and tapping  several times.

2.  → 

Measurement of trip distance 1 starts.

To start measurement of trip distance 2, tap .

To stop measurement, do the following.

3. Display navigation aid information 3 screen by selecting  and tapping  several times.

4.  → 



Measurement of trip distance 1 stops.

To stop measurement of trip distance 2, tap .

4.18.2 Resetting a trip distance

A trip distance can be reset.
Once a trip distance is reset, it is set to zero.

Procedure

1. Display navigation aid information screen 3 by selecting  and tapping  several times.

2.  → 

Trip distance 1 is reset.



To reset trip distance 2, tap .

4.19 Displaying external equipment information



Information on the ship speed through water, water temperature, water depth, and tidal stream can be displayed by entering it on the external equipment.

It is possible to make the setting of each layer of the tidal stream to be displayed. Up to five layers can be displayed.

Procedure

1. Display navigation aid information screen 4 by selecting  and tapping  several times.

2.  → 

3. By using  or , select a layer (layer A to layer E) to be set.

Item	Description
SELECT	SELECT: Set a Layer Number. ALL: Displays the data having the highest Layer Number.
LAYER	Specify a Layer Number to be displayed.
DATA SETTING METHOD	SELECT: Set a data set number. ALL: Displays data of all the data set numbers.
DATA	Specify a data set number to be displayed.



Recommended setting

Item	LAYER A	LAYER B	LAYER C	LAYER D	LAYER E
SELECT	SELECT	SELECT	SELECT	SELECT	SELECT
LAYER	1	2	3	4	5
DATA SETTING METHOD	ALL	ALL	ALL	ALL	ALL
DATA	—	—	—	—	—

4.20 Measuring a distance and an azimuth between two points

A distance and an azimuth between any two points can be measured.

Procedure

1. Display navigation aid information screen 5 by selecting  and tapping  several times.

2.  → 

3. Enter a start position.



4. Enter an end position.





5. Select a calculation method.

6. Tap  .

Chapter 5 Maintenance and Inspection

Proper maintenance may greatly affect the lifespan of the equipment. In order to maintain the equipment in peak state, perform the following regularly.

 WARNING	
	Do not perform internal inspections or modifications of the equipment. Inspection or modification by unauthorized personnel may result in fire, electric shock, or equipment failure.
	Please consult with JRC or an affiliate to perform internal inspections or repair.

 CAUTION	
	Do not use benzine, alcohol or thinner when caring this equipment. Doing so may result in removing the paint or changing of properties.
	Wipe off the grime lightly with a dry soft cloth. Wipe with the other than a dry soft cloth may result in equipment injury.
	Use only the specified fuse. Failure to do so may result in fire or equipment failure.
	Use only the specified batteries. Failure to do so may result in equipment failure or malfunction.

5.1 General Maintenance and Inspection

- Operate the equipment under standard power voltage levels (DC 10.8 - 31.2 V).
- The following shows general maintenance and inspection methods using standard tools.

No.	Item	Maintenance and Inspection
1	Cleaning	Clean the panel screen, knobs, and switches with a soft cloth. There are no gears in the unit, so oil lubrication is unnecessary.
2	Parts Securing	Check for loose screws, nuts, and connectors, and connect securely any that have loosened.

Perform inspection of the displayed items when the equipment is functioning normally. Compare operating results to the normal operation values in order to det

5.2 Alerts

Refer to "4.11 Alert Lists" and check if any alert is given or not. If it is, check the details referring to the list shown below.

Main GPS Alert list

Alert ID	Alert title	Alert description text	Alert causes	Category	Priority	Instance
ALF						
3056	Quality reduce	GPSn HDOP exceeded	HDOP Value has been exceeded setting level	B	C	1
3015/3014	Lost Heading	GPSn Loss of heading	Bearing Calculation Error, Unable to Obtain Data	B	W/A※1	2
3055	Not differential	GPSn Differential CORR not applied	In non-DGPS	B	W	1
3062	Core fault	GPSn Antenna open,contact JRC	Sensor Self-Diagnosis Error	B	W	1
3062	Core fault	GPSn Antenna short,contact JRC	Sensor Self-Diagnosis Error	B	W	2
3062	Core fault	GPSn ROM error,contact JRC	Sensor Self-Diagnosis Error	B	W	3
3062	Core fault	GPSn RAM error,contact JRC	Sensor Self-Diagnosis Error	B	W	4
3062	Core fault	GPSn RTC error,contact JRC	Sensor Self-Diagnosis Error	B	W	5
3062	Core fault	Cntln ROM error,contact JRC	Sensor Self-Diagnosis Error	B	W	6
3062	Core fault	Cntln RAM error,contact JRC	Sensor Self-Diagnosis Error	B	W	7
3062	Core fault	Cntln FPGA error,contact JRC	Sensor Self-Diagnosis Error	B	W	8
3062	Core fault	Cntln BACK error,contact JRC	Sensor Self-Diagnosis Error	B	W	9
3006	Invalid IDNO	GPSn Suspected dead battery	Suspected dead battery	B	C	1
3002	Lost core IF	GPSn core1 error,contact JRC	GPS Core 1 Error (Sensor)	B	W	1
3002	Lost core IF	GPSn core2 error,contact JRC	GPS Core 2 Error (Sensor)	B	W	2
3002	Lost core IF	GPSn core3 error,contact JRC	GPS Core 3 Error (Sensor)	B	W	3
3065	Rapid motion	GPSn x gyro input error	X Axis Gyroscope Error (Sensor)	B	W	1
3065	Rapid motion	GPSn y gyro input error	Y Axis Gyroscope Error (Sensor)	B	W	2
3065	Rapid motion	GPSn z gyro input error	Z Axis Gyroscope Error (Sensor)	B	W	3
3065	Rapid motion	GPSn g sensor input error	Tiltmeter Error (Sensor)	B	W	4
3065	Rapid change	GPSn temperature input error	Temperature Sensor Error (Sensor)	B	W	5
10002	GPS malfunction	GPSn error,restart the equipment	Sensor Internal Error	B	W	14~52
3008	Lost core func	GPSn update core1 software	GPS1 No Program(Sensor)	B	W	1
3008	Lost core func	GPSn update core2 software	GPS2 No Program(Sensor)	B	W	2
3008	Lost core func	GPSn update core3 software	GPS3 No Program(Sensor)	B	W	3
3055	Quality reduce	GPSn excessive vibration	Excessive Vibration	B	W	2~5
3008	Lost sens func	Cntln update controller program	Sensor No Program	B	W	4

Alert ID	Alert title	Alert description text	Alert causes	Category	Priority	Instance
ALF						
3015/3014	Lost position	GPS1 Loss of position	Position Calculation Error, Unable to Obtain Data	B	W/A**1	1
3015/3014	Lost position	GPS2 Loss of position	Position Calculation Error, Unable to Obtain Data	B	W/A**1	1
3015/3014	Lost position	GPS3 Loss of position	Position Calculation Error, Unable to Obtain Data	B	W/A**1	1

Sub GPS Alert list

Alert ID	Alert title	Alert description text	Alert causes	Category	Priority	Instance
ALF						
3056	Quality reduce	GPSm HDOP exceeded	HDOP Value has been exceeded setting level	B	C	21
3015/3014	Lost Heading	GPSm Loss of heading	Bearing Calculation Error, Unable to Obtain Data	B	W/A**1	22
3055	Not differential	GPSm Differential CORR not applied	In non-DGPS	B	W	21
3062	Core fault	GPSm Antenna open,contact JRC	Sensor Self-Diagnosis Error	B	W	21
3062	Core fault	GPSm Antenna short,contact JRC	Sensor Self-Diagnosis Error	B	W	22
3062	Core fault	GPSm ROM error,contact JRC	Sensor Self-Diagnosis Error	B	W	23
3062	Core fault	GPSm RAM error,contact JRC	Sensor Self-Diagnosis Error	B	W	24
3062	Core fault	GPSm RTC error,contact JRC	Sensor Self-Diagnosis Error	B	W	25
3062	Core fault	Cntlm ROM error,contact JRC	Sensor Self-Diagnosis Error	B	W	26
3062	Core fault	Cntlm RAM error,contact JRC	Sensor Self-Diagnosis Error	B	W	27
3062	Core fault	Cntlm FPGA error,contact JRC	Sensor Self-Diagnosis Error	B	W	28
3062	Core fault	Cntlm BACK error,contact JRC	Sensor Self-Diagnosis Error	B	W	29
3006	Invalid IDNO	GPSm Suspected dead battery	Suspected dead battery	B	C	21
3002	Lost core IF	GPSm core1 error,contact JRC	GPS Core 1 Error (Sensor)	B	W	21
3002	Lost core IF	GPSm core2 error,contact JRC	GPS Core 2 Error (Sensor)	B	W	22
3002	Lost core IF	GPSm core3 error,contact JRC	GPS Core 3 Error (Sensor)	B	W	23
3065	Rapid motion	GPSm x gyro input error	X Axis Gyroscope Error (Sensor)	B	W	21
3065	Rapid motion	GPSm y gyro input error	Y Axis Gyroscope Error (Sensor)	B	W	22
3065	Rapid motion	GPSn z gyro input error	Z Axis Gyroscope Error (Sensor)	B	W	23
3065	Rapid motion	GPSn g sensor input error	Tiltmeter Error (Sensor)	B	W	24
3065	Rapid change	GPSm temperature input error	Temperature Sensor Error (Sensor)	B	W	25
10002	GPS malfunction	GPSm error,restart the equipment	Sensor Internal Error	B	W	214 ~ 252
3008	Lost core func	GPSm update core1 software	GPS1 No Program(Sensor)	B	W	21

Alert ID ALF	Alert title	Alert description text	Alert causes	Category	Priority	Instance
3008	Lost core func	GPSm update core2 software	GPS2 No Program(Sensor)	B	W	22
3008	Lost core func	GPSm update core3 software	GPS3 No Program(Sensor)	B	W	23
3055	Quality reduce	GPSm excessive vibration	Excessive Vibration	B	W	22~25
3008	Lost sens func	Cntlm update controller program	Sensor No Program	B	W	24
3015/3014	Lost position	GPS4 Loss of position	Position Calculation Error, Unable to Obtain Data	B	W/A**1	21
3015/3014	Lost position	GPS5 Loss of position	Position Calculation Error, Unable to Obtain Data	B	W/A**1	21
3015/3014	Lost position	GPS6 Loss of position	Position Calculation Error, Unable to Obtain Data	B	W/A**1	21

Display Alert list

Alert ID ALF	Alert title	Alert description text	Alert causes	Category	Priority	Instance
3062	Display fault	eMMC error,contact JRC	eMMC Deletion, Write Error	B	W	41
3062	Display fault	E2PROM error,contact JRC	E2PROM Deletion, Write Error	B	W	42
3062	Display fault	RAM error,contact JRC	RAM Read, Write Error	B	W	43
3062	Display fault	SIO error,contact JRC	Serial(SIO) Error	B	W	44
3062	Display fault	LAN error,contact JRC	LAN Error	B	W	45

Processing Alert list

Alert ID ALF	Alert title	Alert description text	Alert causes	Category	Priority	Instance
3062	Processor fault	Flash rom1 error,contact JRC	Flash ROM1 Deletion, Write Error	B	W	61
3062	Processor fault	Flash rom2 error,contact JRC	Flash ROM2 Deletion, Write Error	B	W	62
3062	Processor fault	Flash rom3 error,contact JRC	Flash ROM3 Deletion, Write Error	B	W	63
3062	Processor fault	RAM error,contact JRC	RAM Read, Write Error	B	W	64
3062	Processor fault	SIO1 error,contact JRC	Serial(SIO1) Error	B	W	65
3062	Processor fault	SIO2 error,contact JRC	Serial(SIO2) Error	B	W	66
3062	Processor fault	SIO3 error,contact JRC	Serial(SIO3) Error	B	W	67
3062	Processor fault	SIO4 error,contact JRC	Serial(SIO4) Error	B	W	68
3062	Processor fault	SIO5 error,contact JRC	Serial(SIO5) Error	B	W	69
3062	Processor fault	SIO6 error,contact JRC	Serial(SIO6) Error	B	W	70
3062	Processor fault	SIO7 error,contact JRC	Serial(SIO7) Error	B	W	71
3062	Processor fault	SIO8 error,contact JRC	Serial(SIO8) Error	B	W	72
3062	Processor fault	SIO9 error,contact JRC	Serial(SIO9) Error	B	W	73

Alert ID ALF	Alert title	Alert description text	Alert causes	Category	Priority	Instance
3062	Processor fault	SIO10 error,contact JRC	Serial(SIO10) Error	B	W	74
3062	Processor fault	SIO11 error,contact JRC	Serial(SIO11) Error	B	W	75
3062	Processor fault	SIO12 error,contact JRC	Serial(SIO12) Error	B	W	76
3062	Processor fault	SIO13 error,contact JRC	Serial(SIO13) Error	B	W	77
3062	Processor fault	LAN display error,contact JRC	LAN1 Error	B	W	78
3062	Processor fault	LAN1 error,contact JRC	LAN2 Error	B	W	79
3062	Processor fault	LAN2 error,contact JRC	LAN3 Error	B	W	80
3062	Processor fault	BUFF error	Built-in Buffer unit Error	B	W	81
3022	Main power fail	Check the main battery	Main Power fail	B	W	1
3002	Lost sensor IF	GPSn not received from sensor	Main sensor data does not be received	B	W	11
3002	Lost sensor IF	GPSn not responded from sensor	Main sensor response does not be received	B	W	12
3015	Lost sensor IF	GPSn insufficient data	Main sensor data is insufficient	B	W	3
3002	Lost sensor IF	GPSn no output from through port	SENSOR THROUGH DATA from main sensor does not be received	B	W	13
3002	Lost sensor IF	GPSm not received from sensor	Sub sensor data does not be received	B	W	31
3002	Lost sensor IF	GPSm not responded from sensor	Sub sensor response does not be received	B	W	32
3015	Lost sensor IF	GPSm insufficient data	Sub sensor data is insufficient	B	W	23
3002	Lost sensor IF	GPSm no output from through port	SENSOR THROUGH DATA from sub sensor does not be received	B	W	33
3002	Lost display IF	not received from display	Data from display does not be received	B	W	61
3002	Lost display IF	not responded from display	Response from display does not be received	B	W	62
3008	Lost mutual IF	Check another GPS Navigator	Not receive mutual check data	B	W	61
10005	Different config	CCRP discrepancy	CCRP is different	B	W**2	61
10005	Different config	Switch configuration mismatch	Switch configuration is different	B	W**2	62
3032	Threshold exceed	Temperature alert	Temperature value has been exceeded setting level	B**3	W	11
3031	Threshold exceed	Depth alert	Depth value has been exceeded setting level	B**3	A	12
3032	Threshold exceed	Distance alert	Distance value has been exceeded setting level	B	W	13
3032	Threshold exceed	SOG alert	Speed value has been exceeded setting level	B	W	14
3032	Threshold exceed	Wind alert	Wind value has been exceeded setting level	B	W	15

Alert ID	Alert title	Alert description text	Alert causes	Category	Priority	Instance
ALF						
3038	Arrival point	Arrival final waypoint	Arrival final waypoint	B**3	W	1
3031	Threshold exceed	Anchor out	Anchor out	B**3	A**2	1
3035	Look ahead	Boundary	Enter the track	B**3	W**2	1
3024	XTD limit	Cross-track alarm	Cross the track	A**3	A**2	1
3038/3037	Arrival point	Early course change	Early course change	A**3	W/A**1	2
3025	End of track	Reach the set time to final WPT	Reach the set time to final WPT	B**3	W**2	1
3038	Arrival point	Arrived at WOL	Arrived at WOL	B**3	W	3
3028/3027	Course change	Actual course change	Actual course change	A**3	W/A**1	1

• All alerts grant a responsibility transfer.

※1 Escalate from warning to alarm.

※2 If it is rectified, it will be normal status without acknowledgement.

※3 These are alerts for non-SOLAS ship. Do not use on SOLAS ship.

When an alert occurs, a pop-up will be displayed.

Alert pop-up example

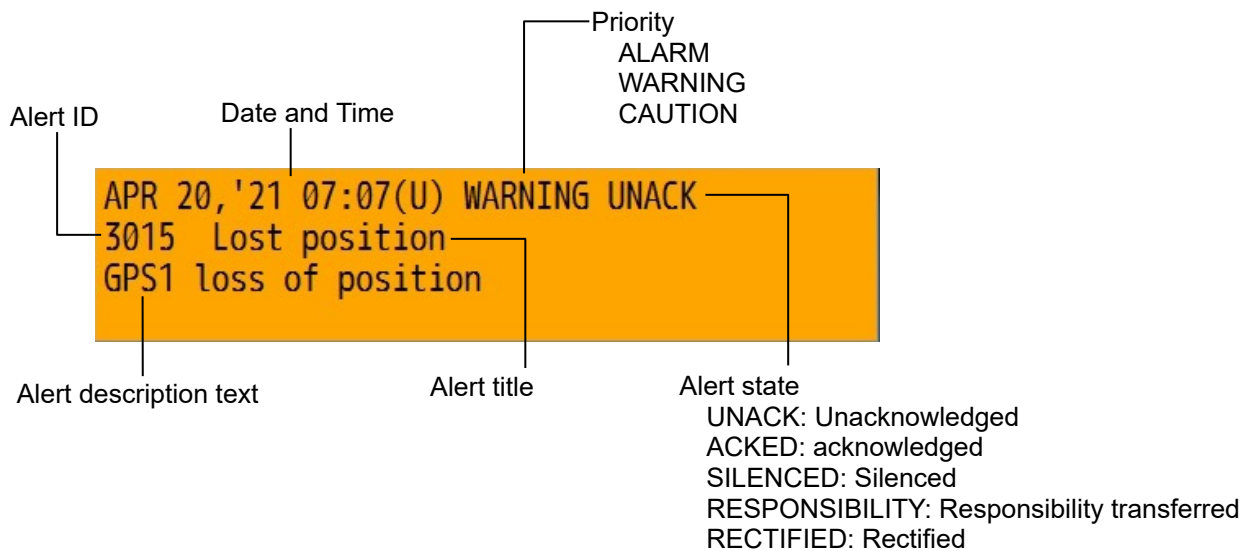

Grouping list

Alert ID	alert title	alert description text	Group member**2)		category	priority
			Alert description for member	Alert ID for member		
11002/ 11001	Sensor1 fail	GPSn Sensor communication fail	GPSn Loss of position	3015/3014	B	W/A**1
			GPSn not received from sensor	3002		
			GPSn not responded from sensor	3002		
			GPSn insufficient data	3015		
11005/ 11004	Sensor2 fail	GPSm Sensor communication fail	GPSn Loss of posiiton	3015/3014	B	W/A**1
			GPSn not received from sensor	3002		
			GPSn not responded from sensor	3002		
			GPSn insufficient data	3015		
11008	Display fail	Display communication fail	not received from display	3002	B	W
			not responded from display	3002		

※1 Escalate from warning to alarm.

※2 Refer to Alert list for the cause of alert.

n: Main GPS number

m: Sub GPS number

Aggregation list

Alert ID	alert title	alert description text	Aggregation member※1		category	priority
			Alert description for member	Alert ID for member		
3062	System fault	xx aggregation alerts	GPSn Antenna open,contact JRC	3062	B	W
			GPSn Antenna short,contact JRC			
			GPSn ROM error,contact JRC			
			GPSn RAM error,contact JRC			
			GPSn RTC error,contact JRC			
			Cntln ROM error,contact JRC			
			Cntln RAM error,contact JRC			
			Cntln FPGA error,contact JRC			
			Cntln BACK error,contact JRC			
			GPSm Antenna open,contact JRC			
			GPSm Antenna short,contact JRC			
			GPSm ROM error,contact JRC			
			GPSm RAM error,contact JRC			
			GPSm RTC error,contact JRC			
			Cntlm ROM error,contact JRC			
			Cntlm RAM error,contact JRC			
			Cntlm FPGA error,contact JRC			
			Cntlm BACK error,contact JRC			
			eMMC error,contact JRC			
			E2PROM error,contact JRC			
			RAM error,contact JRC			
			SIO error,contact JRC			
			LAN error,contact JRC			
			Flash rom1 error,contact JRC			
			Flash rom2 error,contact JRC			
			Flash rom3 error,contact JRC			
			RAM error,contact JRC			
			SIO1 error,contact JRC			
			SIO2 error,contact JRC			
			SIO3 error,contact JRC			
			SIO4 error,contact JRC			
			SIO5 error,contact JRC			
			SIO6 error,contact JRC			
SIO7 error,contact JRC						
SIO8 error,contact JRC						
SIO9 error,contact JRC						
SIO10 error,contact JRC						
SIO11 error,contact JRC						
SIO12 error,contact JRC						
SIO13 error,contact JRC						
LAN display error,contact JRC						
LAN1 error,contact JRC						
LAN2 error,contact JRC						
BUFF error						

※1 Refer to Alert list for the cause of alert.

xx: Number of occurrence alert. n: Main GPS number m: Sub GPS number

5.3 Troubleshooting

WARNING



Do not perform internal inspections or modifications of the equipment. Inspection or modification by unauthorized personnel may result in fire, electric shock, or equipment failure.



Please consult with JRC or an affiliate to perform internal inspections or repair.

For your reference, the guideline for detecting faulty sections is provided below.

Fault symptom	Possible cause/cause of failure	Action to be taken
The power is not supplied even if the power switch of the display unit is pressed.	The power is not supplied from the on-board power panel.	Check if the breaker and the power board are wired correctly.
	The power is not supplied from the power supply unit, which is the option.	Check if the power supply unit is wired correctly.
	The display is faulty.	Contact us or your distributor.
	The fuse of the processor is blown out.	After checking if the wiring is correct and replace the fuse.
	The main switch of the processor is set to OFF.	After checking if the wiring is correct, set the switch to ON.
	The LAN port for display connection on the processor is incorrect.	Connect to the correct LAN port.
LCD does not display a screen.	The display unit is faulty.	Contact us or your distributor.
	Power is not supplied to the display unit.	Check the cable connection.
The brightness is not changed.	The display unit is faulty.	Contact us or your distributor.
No buzzer sound is emitted.	The buzzer is faulty.	Contact us or your distributor.
	The buzzer is set to OFF.	Set buzzer sound on for each alert setting.
No key-tone is emitted.	The buzzer is faulty.	Contact us or your distributor.
	The key-tone is set to OFF.	Refer to 4.3.2 for the setting.
Symbols on the plot screen are not displayed.	The display of the symbols on the plot screen is set to OFF.	Refer to 4.8.9 for the setting.

Fault symptom	Possible cause/cause of failure	Action to be taken
Does not perform position fixing	The sensor is faulty.	Contact us or your distributor.
	The sensor is hidden behind the obstacle.	Move the sensor to the location free from obstacles.
	Noise is entered.	Move the sensor from the noise generating source.
	Power is not supplied to the sensor.	Check the cable connection. Check the output power from the processor.
Data is not received from the sensor to the processor.	The sensor cable is disconnected.	Check the cable connection.
	The connection terminal on the processor is incorrect.	Check the cable connection.
	Power is not supplied to the sensor.	Check the output power from the processor.
Data is not displayed.	The display is faulty.	Contact us or your distributor.
	The display cable is disconnected.	Check the cable connection.
Output to the external equipment does not function.	The setting of the output port is incorrect.	Check the port setting.
	The connection terminal on the processor is incorrect.	Check the cable connection.
	The processor is faulty.	Contact us or your distributor.
Reception from the external equipment does not function.	The setting of the input port is incorrect.	Check the port setting.
	The connection terminal on the processor is incorrect.	Check the cable connection.
	The processor is faulty.	Contact us or your distributor.
The built-in switch does not function.	The switch is faulty.	Contact us or your distributor.
	The setting of the switch port is incorrect.	Check the port setting.
	The connection terminal on the processor is incorrect.	Check the cable connection.
Output from the built-in buffer does not function.	The buffer is faulty.	Contact us or your distributor.
	The setting of the buffer port is incorrect.	Check the port setting.
	The connection terminal on the processor is incorrect.	Check the cable connection.
	The dip-switch setting is incorrect.	Check the dip-switch setting.
The route cannot be shared. The printer does not function.	The port setting is incorrect.	Check the port setting.
	The connection terminal on the processor is incorrect.	Check the cable connection.
	The processor is faulty.	Contact us or your distributor.
The printer does not function.	The setting of the printer is incorrect.	Check the printer setting.
	The connection terminal on the processor is incorrect.	Check the cable connection.
	The processor is faulty.	Contact us or your distributor.

5.4 Replacement Parts

5.4.1 Repair units

The following table shows the repair unit replacement units.

No.	Name	Model	Remarks
1	Receiver processing unit	CMJ-610	GPS sensor
2	Antenna radome replacement kit	MPAE30720	JLR-4350
3	Processing unit	CMJ-611	Processor
4	Terminal block	CMH-2500	NDC-4100
5	LCD panel kit	CCN-1650-U	Display unit
6	Control board	CMJ-612	NWZ-1650
7	Fuse	7ZXNA4028	Processor NDC-4100

To replace the sensor repair unit, also replace the radome and packing with the antenna radome replacement kit.

5.4.2 Regular replacement parts

No.	Name	Model	Replacement time	Remarks
1	LCD unit	CCN-1650-U	40,000 hours	About 5 years in continuous use as the guideline

Chapter 6 After-Sales Service

6.1 Warranty

- Specific periods may vary based on our warranty policies, but the standard warranty period is **one year** from the date of purchase.

6.2 Repair parts stocking Period

- We keep functional repair parts for this equipment (parts necessary for the functioning of this equipment) in stock for 10 years from the discontinuation of production.

6.3 When Requesting Service

When you think the equipment is not operating properly, please read "5.3 Troubleshooting" carefully, and inspect the equipment again. If the problem persists, stop using the equipment, and consult your dealer, or a JRC branch or affiliate.

- **Repairs during the warranty period**
Should a malfunction or failure occur when the equipment is operated according to the descriptions and instructions contained herein, it is repaired free of charge during the warranty period by JRC or another location specified by your dealer. However, any repair for failures resulting from misuse, negligence, or natural disasters, fire, or other Acts of God is charged.
- **Repairs after the warranty period**
Repairs to restore the proper equipment operation can be made at a specified rate with the user's consent. In this case, the equipment can either be sent to JRC or an affiliate, or on-ship repairs can be performed at a location specified by JRC or a sales affiliate. Repairs which cannot be performed on-board the ship needs to be performed in a repair plant.
- **Information that needs to be provided when requesting service**
 - Name, model, production date, and serial number
 - Detailed description of the malfunction (alert number, etc.)
 - Name, address, and telephone number of your company or organization

6.4 Recommended Checks Inspection

Equipment performance is subject to degradation due to age and change of component conditions over time. In addition to your own routine check, additional inspection and maintenance is recommended. Please consult with your dealer or one of our local offices. Note that this inspection and maintenance is not free of charge.

If you have any other questions about after-sales service, please direct your inquiries to your dealer or nearest local office.

A list of branches is provided at the end of the "Contact List".

Chapter 7 Disposal

WARNING



When disposing of the used lithium battery, place insulating tape over the battery terminals, or otherwise insulate the battery. Failure to do so may result in heating, explosion, or fire due to a shorted battery.

7.1 Disposal of Equipment

- Observe all rules and regulations of the local authorities when disposing of this equipment.

7.2 Disposal of Used Batteries

This equipment contains a lithium battery.

- When disposing of the used lithium battery, place insulating tape over the battery terminals, or otherwise insulate the battery. Dispose of the battery properly as directed by the local authorities. Consult your dealer, our sales office, or the local authorities for further details on disposal methods.

Chapter 8 Specification

8.1 NWZ-1650 DISPLAY UNIT

8.1.1 Basic

- Display Unit 6.5 inch Color LCD 640×480 dots
- Touch Screen Available
- Brightness 800cd/m2(Typical)
- Viewing Angle 80 degree at all angle
- Backlight LCD and Key lighting
- Dimmer Levels 16 steps
- Data Input/Output LAN × 1
IEC61162-1 input × 1
- Power Supply Voltage DC12/24V (+30%,-10%)
- Power Consumption less than 10W
- Dimension 160(W)×180(H)×50.5(D)mm (Not include Base)
- Mass Approximately 0.8kg (Not include Base)
- Software version R56.01
- Viewing Distance 1m
- Compass safe distance standard: 0.6m Steering: 0.3m

8.1.2 Environment

- Operating Temperature -15°C~+55°C
- Storage Temperature -25°C~+70°C
- Vibration IEC60945 Ed.4 conformant
- EMC IEC60945 Ed.4 conformant
- Waterproofing IP56
Permanent installation in an exposed section requires a waterproof cover.

8.2 JLR-4350 GPS Sensor

8.2.1 Basic

- GNSS GPS/GLONASS/BeiDou/SBAS/QZSS
Can not receive GLONASS and BeiDou at the same time.
- Maximum Number of Tracked Satellites 22 satellites
- Accuracy GPS : 5m 2DRMS (HDOP \leq 4 SA off)
Beacon DGPS : 4m 2DRMS
SBAS : 4m 2DRMS
- SBAS WAAS、MSAS、EGNOS
- QZSS QZSS(L1-C/A) No.1 Satellite only
- Geodetic datum Selection among 48 geodetic datum (Default : WGS-84)
- Power Supply Voltage DC12/24V (+30%,-10%)
- Power Consumption less than 1.0W
- Dimensions 134(Φ)mm \times 129(H)mm
- Mass Approximately 1.2kg (Include 15m cable)
- Software version R41.0
- Compass safe distance standard: 1.0m Steering: 0.7m

8.2.2 Environment

- Operating Temperature -25 $^{\circ}$ C \sim +55 $^{\circ}$ C
- Storage Temperature -40 $^{\circ}$ C \sim +70 $^{\circ}$ C
- Vibration IEC60945 ed.4 conformant
- EMC IEC60945 ed.4 conformant
- Waterproofing IP56

8.3 NDC-4100 Processor Unit

8.3.1 Basic

- Memories Waypoints 10000points maximum
Event/Mark 1000points maximum (include MOB)
Track 2000points maximum
Route 100routes maximum
- Route plan 512 waypoints per one route
- Magnetic Variation Automatic or manual
- Navigation Calculation Grate circle or Rhumb line selectable
- Alert Arrival, Anchor, Boundary, XTD, No position fix, Speed, Trip, HDOP
Temperature*, Depth*
- Plot Function Scale 0.2,0.5,1,2,5,10,20,50,100,200,300NM
Interval 1~60min (1 sec) or 0.01~99.99NM (0.01NM) selectable
- Data Input/Output IEC61162-1 Output ×5, Input ×2
IEC61162-2 Output ×1, Input ×1
Buffer Unit: IEC61162-1 Output ×8
RS-232C Output ×1, Input ×1
IEC61162-450 LAN×2
- Dry Contact Output ×4, Input ×1
- Remote maintenance Available
- Unit Distance, Speed : NM,kn or km,km/h or mi,mi/h
Height, Depth : m or ft or fm
Temperature : °C or °F
- Loran C/A Latitude and Longitude can be converted into the Loran time difference
- Language Japanese or English
- 8ch Buffer Built-in
- 2ch Select Switch Built-in
- Power Supply Voltage DC12/24V (+30%,-10%)
- Power Consumption 15W 以下
JLR-8600 : less than 25W
- Dimensions 264(W)mm×100(H)mm×281(D)mm
- Mass Approximately 1.9kg
- Software version R60.02
- Compass safe distance standard: 0.7m Steering: 0.4m

* : External sensor must be connected

8.3.2 Environment

- Operating Temperature -15°C~+55°C
- Storage Temperature -25°C~+70°C
- Vibration IEC60945 ed.4 conformant
- EMC IEC60945 ed.4 conformant
- Waterproofing IP22

8.3.3 Interface

1) Serial Transmission

Channel	Signal	Input / Output	Format
IN/OUT 1	RS-422	Input	IEC61162-2/NMEA
		Output	IEC61162-2/NMEA/JRC/SWITCH/SC-104
IN/OUT 2	RS-422	Input	IEC61162-1/NMEA
		Output	IEC61162-1/NMEA/JRC/SWITCH/SC-104
IN/OUT 3	RS-422	Input	IEC61162-1/NMEA
		Output	IEC61162-1/NMEA/JRC/SWITCH/SC-104
OUT 4	RS-422	Output	IEC61162-1/NMEA/JRC/SWITCH/SC-104
OUT 5	RS-422	Output	IEC61162-1/NMEA/JRC/SWITCH/SC-104
OUT 6	RS-422	Output	IEC61162-1/NMEA/JRC/SWITCH/SC-104
BUFFER	RS-422	Output	IEC61162-1/NMEA
RS-232C	RS-232C	Input	IEC61162-1/NMEA
		Output	IEC61162-1/NMEA

JLR-8600 does not support a SC-104 output format.

Note) The number of listener that can be connected to one output port is recommended to one port.
IN/OUT1, IN/OUT2 and IN/OUT3 port is possible for BAM connection.

1-1) NMEA

- Specification NMEA0183
- Version Ver1.5,2.1,2.3,4.0
- Bit Rate 4800,9600,19200,38400bps
- Data Bit 8bit
- Parity None
- Start Bit 1bit
- Stop Bit 1bit
- Output Sentence GGA,RMC, GLL,VTG,GSA,GSV,DTM,GBS,GRS,GST,ZDA,GNS,ALR,APB,BOD,BWC,BWR,RMB,XTE,ZTG,AAM,RTE,WPL,ACK,ALC,ALF,HBT,ARC,AGLACN,HDT*,THS*,DBT*,DPT*,MTW*,CUR*,VBW*,VHW*,MWV*,VWR*,VWT*
- Output Interval 1s,2s,3s,4s,5s,6s,7s,8s,9s,OFF
- Input Sentence HDT,THS,DBT,DPT,MTW,CUR,VBW,VHW,ACK,WPL,RTE,ALR,ACN,ALC,ALF,HBT, MWV,VWR,VWT

*External sensor must be connected

Note) Some combinations of output sentence, bit rates, and output intervals may not be possible.

1-2) IEC

- Specification IEC61162-1 Ed.5

1-3)JRC

- Specification : JRC
- Bit Rate : 1200bps
- Data Bit : 8bit
- Parity : None
- Start Bit : 1bit
- Stop Bit : 2bit

2) Dry Contact

Channel	Input / Output	None
Contact 1,2,3,4	Output	Alert, 200p/NM, 400p/NM, ACK
Contact 5	Input	ACK

3)LAN

- Specification : IEC61162-450/JRC
- Bit Rate : 10/100Mbps
- Shared route : JRC Format
- Data output : NMEA,IEC

- Datagram type : UdpBc
- Cluster : Nav
- Transmission group :

Transmission group	Category
NAVD	Output of the GPS data.
BAM1	Output of alert communication.
CAM1	Input of alert communication.
NETA	Output SRP sentence to assist detection of collision of the SFI.

Appendix

Appendix 1 List of Geodetic System

Display	Setting		Geodetic System
W84	WGS-84	0	WGS-84
W72	WGS-72	1	WGS-72
TOY	JAPAN	2	Tokyo Datum
NAS	NAD27 USA	3	North American 1927 (USA)
NAS	NAD27 CAN	4	North American 1927 (Canada, Alaska)
EUR	EUROPE 50	5	Europe 1950 (Europe)
AUA	AUSTRALIA 66	6	Australian geodetic 1966 (Australia)
OGB	OSGB-36	7	Ordnance Survey of Great Britain (England)
NAR	NAD-83	8	NAD-83
ADI	ADI	11	Adindan (Ethiopia, Sudan)
ARF	ARF	12	ARC 1950 (Botswana)
AUG	AUG	13	Australian Geodetic 1984 (Australia)
BER	BER	14	Bermuda 1957 (Bermuda islands)
BOO	BOO	15	Bogota Observatory (Columbia)
CAI	CAI	16	Compo Inchauspe (Argentine)
CHI	CHI	17	Chatham 1971 (Chatham Islands)
CHU	CHU	18	Chua Astro (Paraguay)
COA	COA	19	Corrego Alegre (Brazil)
BAT	BAT	20	Djakarta (Vatavia) (Sumatra)
EUR	EUR	21	European 1979 (Europe)
GEO	GEO	22	Geodetic Datum 1949 (New Zealand)
GUA	GUA	23	Guam 1963 (Guam)
GRA	GRA	24	Hayford 1910 (Finland)
HJO	HJO	25	Hjorsey 1955 (Iceland)
IND	IND	26	Indian (India, Nepal)
IRL	IRL	27	Ireland 1965 (Ireland)
KEA	KEA	28	Kertau 1948 (West Malaysia, Singapore)
LCF	LCF	29	L.C.5 Astro (Cayman Brac island)
LIB	LIB	30	Liberia 1964 (Liberia)
LUZ	LUZ	31	Luzon (Philippines)
MER	MER	32	Merchich (Morocco)
MIN	MIN	33	Minna (Cameroon)
NAH	NAH	34	Nahrwan (Oman)
NAP	NAP	35	Naparima, BWI (Trinidad and Tobago)
OEG	OEG	36	Old Egyptian (Egypt)
OHA	OHA	37	Old Hawaiian (Hawaiian Islands)
PLN	PLN	38	Pico de las Nieves (Canary Islands)
PRP	PRP	39	Provisional south American 1956 (South America)
HIT	HIT	40	Provisional south Chilean 1963 (South Chile)
PUR	PUR	41	Puerto Rico (Puerto Rico, Virgin Islands)
QUO	QUO	42	Qornoq (South Greenland)
043	043	43	RT90 (Sweden)
SAO	SAO	44	Santa Braz (San Miguel, Santa Maria islands)
SAN	SAN	45	South American 1969 (South America)
046	046	46	Southwest Base (Faial, Gracinao, Pico, San Jorge, Terceira islands)
TIL	TIL	47	Timbalai 1948 (Brunei, Malaysia)
048	048	48	PZ-90.02
SPK	SPK	49	SK-42 (Pulkovo 42)

Appendix 2 List of standard terms, units and abbreviations

Term	Abbreviation	Term	Abbreviation
Acknowledge	ACK	Calibrate	CAL
Acquire, Acquisition	ACQ	Cancel	CNCL
Acquisition Zone	AZ	Carried (for example, carried EBL origin)	C
Adjust, Adjustment	ADJ	Central Processing Unit	CPU
Aft	AFT	Centre	CENT
Alarm	ALARM	Change	CHG
Altitude	ALT	Circularly Polarised	CP
Amplitude Modulation	AM	Clear	CLR
Anchor Watch	ANCH	Closest Point of Approach	CPA
Antenna	ANT	Compact Disk Read Only Memory	CDROM
Anti Clutter Rain	RAIN	Consistent Common Reference Point	CCRP
Anti Clutter Sea	SEA	Consistent Common Reference System	CCRS
April	APR	Contrast	CONT
Audible	AUD	Coordinated Universal Time	UTC
August	AUG	Correction	CORR
Automatic	AUTO	Course	CRS
Automatic Frequency Control	AFC	Course Over the Ground	COG
Automatic Gain Control	AGC	Course Through the Water	CTW
Automatic Identification System	AIS	Course To Steer	CTS
Automatic Identification System – Search and Rescue Transmitter	AIS-SART	Course Up	C UP ^a
Automatic Radar Plotting Aid	ARPA	Cross Track Distance	XTD
Autopilot	AP	Cursor	CURS
Auxiliary System/Function	AUX	Dangerous Goods	DG
Available	AVAIL	Date	DATE
Azimuth Indicator	AZI	Day	DAY
Background	BKGND	Dead Reckoning, Dead Reckoned Position	DR
Bearing	BRG	December	DEC
Bearing Waypoint To Waypoint	BWW	Decrease	DECR
Bow Crossing Range	BCR	Delay	DELAY
Bow Crossing Time	BCT	Delete	DEL
Brilliance	BRILL	Departure	DEP
Built in Test Equipment	BITE	Depth	DPTH

Term	Abbreviation
<i>Destination</i>	<i>DEST</i>
<i>Deviation</i>	<i>DEV</i>
<i>Differential GLONASS</i>	<i>DGLONASS</i>
<i>Differential GNSS</i>	<i>DGNSS^a</i>
<i>Differential GPS</i>	<i>DGPS^a</i>
<i>Digital Selective Calling</i>	<i>DSC</i>
<i>Display</i>	<i>DISP</i>
<i>Distance</i>	<i>DIST</i>
<i>Distance Root Mean Square</i>	<i>DRMS^a</i>
<i>Distance To Go</i>	<i>DTG</i>
<i>Drift</i>	<i>DRIFT</i>
<i>Dropped (for example, dropped EBL origin)</i>	<i>D</i>
<i>East</i>	<i>E</i>
<i>Echo Reference</i>	<i>REF</i>
<i>Electronic Bearing Line</i>	<i>EBL</i>
<i>Electronic Chart Display and Information System</i>	<i>ECDIS</i>
<i>Electronic Chart System</i>	<i>ECS</i>
<i>Electronic Navigational Chart</i>	<i>ENC</i>
<i>Electronic Position Fixing System</i>	<i>EPFS</i>
<i>Electronic Range and Bearing Line</i>	<i>ERBL</i>
<i>Emergency Position Indicating Radio Beacon</i>	<i>EPIRB</i>
<i>Emergency Position Indicating Radio Beacon – AIS</i>	<i>EPIRB-AIS</i>
<i>Enhance</i>	<i>ENH</i>
<i>Enter</i>	<i>ENT</i>
<i>Equipment</i>	<i>EQUIP</i>
<i>Error</i>	<i>ERR</i>
<i>Estimated Position</i>	<i>EP</i>
<i>Estimated Time of Arrival</i>	<i>ETA</i>
<i>Estimated Time of Departure</i>	<i>ETD</i>
<i>European Geo-Stationary Navigational Overlay System</i>	<i>EGNOS</i>
<i>Event</i>	<i>EVENT</i>
<i>Exclusion Zone</i>	<i>EZ</i>
<i>External</i>	<i>EXT</i>
<i>F-Band (applies to radar)</i>	<i>F-Band</i>
<i>February</i>	<i>FEB</i>
<i>Foreword</i>	<i>FWD</i>
<i>Fishing Vessel</i>	<i>FISH</i>

Term	Abbreviation
<i>Fix</i>	<i>FIX</i>
<i>Forward</i>	<i>FWD</i>
<i>Frequency</i>	<i>FREQ</i>
<i>Frequency Modulation</i>	<i>FM</i>
<i>Full</i>	<i>FULL</i>
<i>Gain</i>	<i>GAIN</i>
<i>Geographics</i>	<i>GEOG</i>
<i>Geometric Dilution Of Precision</i>	<i>GDOP</i>
<i>Global Maritime Distress and Safety System</i>	<i>GMDSS</i>
<i>Global Navigation Satellite System</i>	<i>GNSS</i>
<i>Global Orbiting Navigation Satellite System</i>	<i>GLONASS</i>
<i>Global Positioning System</i>	<i>GPS</i>
<i>Great Circle</i>	<i>GC</i>
<i>Grid</i>	<i>GRID</i>
<i>Ground</i>	<i>GND</i>
<i>Grounding Avoidance System</i>	<i>GAS</i>
<i>Group Repetition Interval</i>	<i>GRI</i>
<i>Guard Zone</i>	<i>GZ</i>
<i>Gyro</i>	<i>GYRO</i>
<i>Harmful Substances (applies to AIS)</i>	<i>HS</i>
<i>Head Up</i>	<i>H UP^a</i>
<i>Heading</i>	<i>HDG</i>
<i>Heading Control System</i>	<i>HCS</i>
<i>Heading Line</i>	<i>HL</i>
<i>High Frequency</i>	<i>HF</i>
<i>High Speed Craft</i>	<i>HSC</i>
<i>Horizontal Dilution Of Precision</i>	<i>HDOP</i>
<i>Identification</i>	<i>ID</i>
<i>In</i>	<i>IN</i>
<i>Increase</i>	<i>INCR</i>
<i>Indication</i>	<i>IND</i>
<i>Information</i>	<i>INFO</i>
<i>Infrared</i>	<i>INF RED</i>
<i>Initialisation</i>	<i>INIT</i>
<i>Input</i>	<i>INP</i>
<i>Input/Output</i>	<i>I/O</i>
<i>Integrated Navigation System</i>	<i>INS</i>
<i>Integrated Radio Communication System</i>	<i>IRCS</i>
<i>Interference Rejection</i>	<i>IR</i>







Term	Abbreviation	Term	Abbreviation
<i>Interswitch</i>	<i>ISW</i>	Not Less Than	NLT
<i>Interval</i>	<i>INT</i>	Not More Than	NMT
<i>January</i>	<i>JAN</i>	Not Under Command	NUC
<i>July</i>	<i>JUL</i>	<i>November</i>	<i>NOV</i>
<i>June</i>	<i>JUN</i>	<i>October</i>	<i>OCT</i>
Label	LBL	<i>Off</i>	<i>OFF</i>
<i>Latitude</i>	<i>LAT</i>	<i>Officer On Watch</i>	<i>OOW</i>
Latitude/Longitude	L/L	<i>Offset</i>	<i>OFFSET</i>
Leeway	LWY	<i>On</i>	<i>ON</i>
<i>Limit</i>	<i>LIM</i>	<i>Out/Output</i>	<i>OUT</i>
<i>Line Of Position</i>	<i>LOP</i>	<i>Own Ship</i>	<i>OS</i>
<i>Log</i>	<i>LOG</i>	<i>Panel Illumination</i>	<i>PANEL</i>
<i>Long Pulse</i>	<i>LP</i>	<i>Parallel Index Line</i>	<i>PI</i>
<i>Long Range</i>	<i>LR</i>	Past Positions	PAST POSN
<i>Longitude</i>	<i>LON</i>	<i>Passenger Vessel</i>	<i>PASSV</i>
<i>Loran</i>	<i>LORAN</i>	<i>Performance Monitor</i>	<i>MON</i>
<i>Lost Target</i>	<i>LOST TGT</i>	<i>Permanent</i>	<i>PERM</i>
<i>Low Frequency</i>	<i>LF</i>	<i>Person Overboard</i>	<i>POB</i>
<i>Magnetic</i>	<i>MAG</i>	<i>Personal Identification Number</i>	<i>PIN</i>
Man Overboard	MOB	<i>Pilot Vessel</i>	<i>PILOT</i>
<i>Manoeuvre</i>	<i>MVR</i>	<i>Port/Portside</i>	<i>PORT</i>
<i>Manual</i>	<i>MAN</i>	<i>Position</i>	<i>POSN</i>
<i>Map(s)</i>	<i>MAP</i>	<i>Positional Dilution Of Precision</i>	<i>PDOP</i>
<i>March</i>	<i>MAR</i>	<i>Power</i>	<i>PWR</i>
<i>Maritime Mobile Services Identity number</i>	<i>MMSI</i>	<i>Predicted</i>	<i>PRED</i>
<i>Maritime Pollutant (applies to AIS)</i>	<i>MP</i>	<i>Predicted Area of Danger</i>	<i>PAD</i>
<i>Maritime Safety Information</i>	<i>MSI</i>	<i>Predicted Point of Collision</i>	<i>PPC</i>
<i>Marker</i>	<i>MKR</i>	<i>Pulse Length</i>	<i>PL</i>
<i>Master</i>	<i>MSTR</i>	<i>Pulse Modulation</i>	<i>PM</i>
<i>Maximum</i>	<i>MAX</i>	<i>Pulse Repetition Frequency</i>	<i>PRF</i>
<i>May</i>	<i>MAY</i>	<i>Pulse Repetition Rate</i>	<i>PRR</i>
<i>Medium Frequency</i>	<i>MF</i>	<i>Pulses Per Revolution</i>	<i>PPR</i>
<i>Medium Pulse</i>	<i>MP</i>	<i>Racon</i>	<i>RACON</i>
<i>Menu</i>	<i>MENU</i>	<i>Radar</i>	<i>RADAR</i>
<i>Minimum</i>	<i>MIN</i>	Radar Plotting	RP
<i>Missing</i>	<i>MISSING</i>	Radar Transponder	TPR
<i>Mute</i>	<i>MUTE</i>	<i>Radius</i>	<i>RAD</i>
<i>Navigation</i>	<i>NAV</i>	<i>Rain</i>	<i>RAIN</i>
<i>Night</i>	<i>NT</i>	<i>Range</i>	<i>RNG</i>
<i>Normal</i>	<i>NORM</i>	<i>Range Rings</i>	<i>RR</i>
<i>North</i>	<i>N</i>	<i>Raster Chart Display System</i>	<i>RCDS</i>
<i>North Up</i>	<i>N UP^a</i>		

Term	Abbreviation	Term	Abbreviation
<i>Raster Navigational Chart</i>	<i>RNC</i>	<i>Synchronised/ Synchronous</i>	<i>SYNC</i>
<i>Rate Of Turn</i>	<i>ROT</i>	<i>System Electronic Navigational Chart</i>	<i>SENC</i>
<i>Real-time Kinematic</i>	<i>RTK</i>	<i>Target</i>	<i>TGT</i>
<i>Receive</i>	<i>RX^a</i>	<i>Target Tracking</i>	<i>TT</i>
<i>Receiver</i>	<i>RCDR</i>	<i>Test</i>	<i>TEST</i>
<i>Receiver Autonomous Integrity Monitoring</i>	<i>RAIM</i>	<i>Time</i>	<i>TIME</i>
<i>Reference</i>	<i>REF</i>	<i>Time Difference</i>	<i>TD</i>
<i>Relative</i>	<i>REL^b</i>	<i>Time Dilution Of Precision</i>	<i>TDOP</i>
<i>Relative Motion</i>	<i>RM</i>	<i>Time Of Arrival</i>	<i>TOA</i>
<i>Revolutions per Minute</i>	<i>RPM</i>	<i>Time Of Departure</i>	<i>TOD</i>
<i>Rhumb Line</i>	<i>RL</i>	<i>Time to CPA</i>	<i>TCPA</i>
<i>Roll On/Roll Off Vessel</i>	<i>RoRo</i>	<i>Time To Go</i>	<i>TTG</i>
<i>Root Mean Square</i>	<i>RMS</i>	<i>Time to Wheel Over Line</i>	<i>TWOL</i>
<i>Route</i>	<i>ROUTE</i>	<i>Track</i>	<i>TRK</i>
<i>Safety Contour</i>	<i>SF CNT</i>	<i>Track Control System</i>	<i>TCS</i>
<i>Sailing Vessel</i>	<i>SAIL</i>	<i>Tracking</i>	<i>TRKG</i>
<i>Satellite</i>	<i>SAT</i>	<i>Trail(s)</i>	<i>TRAIL</i>
<i>S-Band</i>	<i>S-BAND</i>	<i>Transmit and Receive</i>	<i>TXRX^a</i>
<i>Scan to Scan</i>	<i>SC/SC</i>	<i>Transceiver</i>	<i>TCVR</i>
<i>Search And Rescue</i>	<i>SAR</i>	<i>Transferred Line Of Position</i>	<i>TPL</i>
<i>Search And Rescue Transponder</i>	<i>SART</i>	<i>Transmit</i>	<i>TX</i>
<i>Search And Rescue Vessel</i>	<i>SARV</i>	<i>Transmitter</i>	<i>TMTR</i>
<i>Select</i>	<i>SEL</i>	<i>Transmitting Heading Device</i>	<i>THD</i>
<i>September</i>	<i>SEP</i>	<i>Trial</i>	<i>TRIAL^c</i>
<i>Sequence</i>	<i>SEQ</i>	<i>Trigger Pulse</i>	<i>TRIG</i>
<i>Set (i.e., set and drift, or setting a value)</i>	<i>SET</i>	<i>True</i>	<i>T</i>
<i>Ship's Time</i>	<i>TIME</i>	<i>True Motion</i>	<i>TM</i>
<i>Short Pulse</i>	<i>SP</i>	<i>Tune</i>	<i>TUNE</i>
<i>Signal to Noise Ratio</i>	<i>SNR</i>	<i>Ultrahigh Frequency</i>	<i>UHF</i>
<i>Simulation</i>	<i>SIM^c</i>	<i>Uninterruptible Power Supply</i>	<i>UPS</i>
<i>Slave</i>	<i>SLAVE</i>	<i>Universal Time, Coordinated</i>	<i>UTC</i>
<i>South</i>	<i>S</i>	<i>Universal Transverse Mercator</i>	<i>UTM</i>
<i>Speed</i>	<i>SPD</i>	<i>Unstabilised</i>	<i>UNSTAB</i>
<i>Speed and Distance Measuring Equipment</i>	<i>SDME</i>	<i>Variable Range Marker</i>	<i>VRM</i>
<i>Speed Over the Ground</i>	<i>SOG</i>	<i>Variation</i>	<i>VAR</i>
<i>Speed Through the Water</i>	<i>STW</i>	<i>Vector</i>	<i>VECT</i>
<i>Stabilised</i>	<i>STAB</i>	<i>Very High Frequency</i>	<i>VHF</i>
<i>Standby</i>	<i>STBY</i>	<i>Very Low Frequency</i>	<i>VLF</i>
<i>Starboard/Starboard Side</i>	<i>STBD</i>	<i>Vessel Aground</i>	<i>GRND</i>
<i>Station</i>	<i>STN</i>	<i>Vessel at Anchor</i>	<i>ANCH</i>
<i>Symbol(s)</i>	<i>SYM</i>		

Term	Abbreviation
<i>Vessel Constrained by Draught</i>	<i>VCD</i>
<i>Vessel Engaged in Diving Operations</i>	<i>DIVE</i>
<i>Vessel Engaged in Dredging or Underwater Operations</i>	<i>DRG</i>
<i>Vessel Engaged in Towing Operations</i>	<i>TOW</i>
<i>Vessel Not Under Command</i>	<i>NUC</i>
<i>Vessel Restricted in Manoeuvrability</i>	<i>RIM</i>
<i>Vessel Traffic Service</i>	<i>VTS</i>
<i>Vessel Underway Using Engine</i>	<i>UWE</i>
<i>Video</i>	<i>VID</i>

Term	Abbreviation
<i>Visual Display Unit</i>	<i>VDU</i>
<i>Voyage</i>	<i>VOY</i>
<i>Voyage Data Recorder</i>	<i>VDR</i>
<i>Warning</i>	<i>WARNING</i>
<i>Water</i>	<i>WAT</i>
<i>Waypoint</i>	<i>WPT</i>
<i>Waypoint Closure Velocity</i>	<i>WCV</i>
<i>West</i>	<i>W</i>
<i>Wheel Over Line</i>	<i>WOL</i>
<i>Wheel Over Point</i>	<i>WOP</i>
<i>Wheel Over Time</i>	<i>WOT</i>
<i>World Geodetic System</i>	<i>WGS</i>
<i>X-Band</i>	<i>X-BAND</i>

Appendix 3 List of Symbols

Symbol name	Symbol graphic
Own ship - simplified symbol	Double circle 
Velocity vector	Short-dashed line 
Past track	Small filled circle 
Waypoint	Circle 
Route	Long-dashed line 
Event	Square with diagonal line 
User cursor	Cross line 

Appendix 4 List of Default Setting Values

MENU	Sub Menu	Sub Menu	Sub Menu	Default			
DISPLAY	THEME			DAY			
	BEEP			ON			
	DAY SCREEN			OFF			
	NAV			ON			
	PLOT			ON			
	ANALOG			ON			
	HIGHWAY			ON			
	SAT INFO			ON			
	WPT INFO			ON			
	BEACON TEXT			ON			
	NAV ASSIST			ON			
VOYAGE	WPT	WPT LIST		-			
	ROUTE	ROUTE LIST		-			
	RUN			-			
	EVENTMARK	EVENTMARK LIST		-			
	WPT COPY			-			
	ROUTE COPY			-			
	WPT DELETE			-			
	ROUTE DELETE			-			
	EVENT DELETE			-			
	SHARED	ROUTE SEND	CONNECT		UNICAST		
			IP		000.000.000.000		
			PORT		0		
			OUTPUT		LAN1		
			FORMAT		NMEA VER 1.5		
			DATA		ALL WPT		
	DEFAULT SETTINGS	ROUTE RECEIVE	SOURCE IP		000.000.000.000		
		WIDTH PORT(NM)			1.00		
WIDTH STBD(NM)					1.00		
			ARRIVAL RADIUS(NM)			1.00	
				SPEED(kn)			10.00
					SAIL		
	SOG SMOOTHING(s)						
		SYSTEM				SET	
SOUND							ON
ARRIVAL/ ANCHOR		SET				OFF	
		SOUND		ON			
XTD/ BOUNDARY		SET		OFF			
	SOUND		ON				
HDOP	SET		THRESHOLD 4				
	SOUND		OFF				
SPD	SET		OFF				
	SOUND		ON				
TRIP	SET		OFF				
	SOUND		ON				
EARLY COURSE CHANGE	SET		OFF				
	SOUND		ON				
END OF TRACK	SET		OFF				
	SOUND		ON				
ARRIVED AT WOL	SET		OFF				
	SOUND		ON				
ACTUAL COURSE CHANGE	SET		OFF				
	SOUND		ON				

MENU	Sub Menu	Sub Menu	Sub Menu	Range		
ALERT	TEMP	SET		OFF		
		SOUND		ON		
	DPTH	SET		OFF		
		SOUND		ON		
	DGPS	SET		OFF		
		SOUND		OFF		
	BUFFER	SET		OFF		
		SOUND		ON		
	POWER	SET		ON		
		SOUND		ON		
	SETTING	ALARM ESCALATION	POSITION		ON	
			HEADING		ON	
			TIME(s)		30	
		HEADER ALERT	GROUPING		OFF	
AGGREGATION				OFF		
TEST MODE			OFF			
GNSS SETTING	SENSOR1	GNSS	GPS MODE	GPS		
		FIX MODE		AUTO		
		ELV MASK		5		
		HDOP		10		
		SMOOTH	POSN SMOOTHING(s)		10	
			SPEED SMOOTHING(s)		10	
			COURSE SMOOTHING(s)		10	
		RAIM	RAIM ACCURACY LEVEL(m)		100	
		DATUM			WGS-84	
		INIT	QUADRANT		-	
			LAT		-	
			LON		-	
			ANT HEIGHT(m)		-	
			YEAR		-	
			MONTH		-	
			DAY		-	
			HOUR(hr)		-	
			MINUTE(min)		-	
		DGPS			AUTO	
		BEACON	AUTO		-	
			MANUAL		283.5kHz/25bps	
			SEMI AUTO		-	
			MONITOR		-	
		SBAS	SAT SEARCH		AUTO	
			TYPE0		OFF	
			RANGING		OFF	
		STN LIST			-	
		GNSS SETTING	SENSOR2	Same as SENSOR1		
		SYSTEM	DATE / TIME	TIME DIFF		+00:00
				DATE DISP		MMM DD,'YY
TIME DISP(hr)				24hr		
UNIT	DIST / SPEED			NM,kn		
	HIGHT / DPTH			m		
	TEMP			°C		
MAG CORR				OFF		
LORAN				OFF		
SENSOR SELECT			AUTO			
LANGUAGE				ENGLISH		

MENU	Sub Menu	Sub Menu	Sub Menu	Sub Menu	Range	
VERSION	DISPLAY				-	
	PROCESSOR				-	
	SENSOR 1				-	
	SENSOR 2				-	
ALERT LIST	ALERT HISTORY				-	
	ACTIVE ALERT				-	
	LAN1				-	
	LAN2				-	
EQUIP	TYPE	TYPE1 / 2 DISPLAY	DISPLAY TYPE		MAIN	
			SFI		GP0000	
		TYPE2/2 PROCESSOR	DEVICE No.		No1	
			SFI		GP0001	
			SENSOR1		GPS	
			SENSOR2		OFF	
	DATA I/O	IN/OUT1	FORMAT		NMEA	
			BITRATE		4800	
			VERSION		2.3	
			TALKER		GNSS	
			SENTENCE		GGA,RMC,VTG,DTM,ZDA, APB,RMB	
		IN/OUT2	Same as IN/OUT1			
		IN/OUT3	Same as IN/OUT1			
		OUT4	Same as IN/OUT1			
		OUT5	Same as IN/OUT1			
		OUT6	Same as IN/OUT1			
	LAN	LAN1	DATA OUT		• Data out MULTICAST 239.192.000.004 60004	
					• Alert Tx MULTICAST 239.192.000.017 60017	
					• Alert Rx MULTICAST 239.192.000.019 60019	
				NMEA/2.3/GNSS GGA,RMC,VTG,DTM,ZDA, APB,RMB		
			RMS SEND		ON MULTICAST 239.192.000.005 60005	
			PRINTER		UNUSED OFF 000.000.000.000 9100	
		LAN2	DATA OUT		Same as LAN1	
RMS SEND				Same as LAN1		
PRINTER			Same as LAN1			

MENU	Sub Menu	Sub Menu	Sub Menu	Sub Menu	Range
EQUIP	DATA I/O		COMMON	ACTIVE ROUTE	OFF MULTICAST 239.000.096.001 6203
				DATA ROUTE	Same as ACTIVE ROUTE
				MUTUAL	OFF MULTICAST 239.000.000.001 5101
		CONTACT1	CONTACT OUT		SYSTEM
		CONTACT2	CONTACT OUT		XTD
		CONTACT3	CONTACT OUT		ACK
		CONTACT4	CONTACT OUT		ARV
		BUFFER	FORMAT		NMEA
			BITRATE(bps)		4800
			VERSION		2.3
			TALKER		GNSS
			SENTENCE		GGA,RMC,VTG,DTM,ZD A,APB,RMB
		SENSOR	SENSOR1 PORT2(bps)		4800
			SENSOR2 PORT2(bps)		4800
		RS-232C	FORMAT		NMEA
			BITRATE(bps)		4800
			VERSION		2.3
			TALKER		GNSS
			SENTENCE		GGA,RMC,VTG,DTM,ZD A,APB,RMB
		SWITCH	CONTROLL METHOD		MFD
	SWITCH SELECTION			PROCESSOR No1.	
	DIMMER	SETTINGS	DIMMER GROUP		1
			DISPLAY		OFF
			NCM-227		OFF
			DIMMER OFFSET		+000
			DDC		OFF
			GPS		OFF
		GP DDC		OFF	
	DIMMER CAL		MIN		
	IP	DISPLAY	IP ADDRESS		172.018.001.169
			MAC ADDRESS		-
			SUBNET MASK		255.255.000.000
			DEFAULT GATEWAY		000.000.000.000
		PROCESSOR LAN 0	IP ADDRESS		172.018.001.163
			MAC ADDRESS		-
			SUBNET MASK		255.255.000.000
			DEFAULT GATEWAY		172.016.060.001

MENU	Sub Menu	Sub Menu	Sub Menu	Sub Menu	Range	
EQUIP		PROCESSOR LAN 1	SETTING		JRC STANDARD	
			IP ADDRESS		172.016.060.163	
			MAC ADDRESS		-	
			SUBNET MASK		255.255.000.000	
			DEFAULT GATEWAY		172.016.060.001	
		PROCESSOR LAN 2	SETTING		JRC STANDARD	
			IP ADDRESS		172.017.060.163	
			MAC ADDRESS		-	
			SUBNET MASK		255.255.000.000	
			DEFAULT GATEWAY		172.016.060.001	
	CCRP	BEAM (m)			1.0	
		LENGTH(m)			1.0	
		CCRP(m)			0.0/0.0/0.0	
		SENSOR1 (m)			0.0/0.0/0.0	
		SENSOR2 (m)			0.0/0.0/0.0	
	CTS	CLASS			TANKER	
		TRACKING GAIN			LOW	
		TRACKING HIGH			2880	
		TORACING MIDDLE			960	
		TRACKING LOW			270	
		TRACKING MULTIPLE			1.0	
		TRACKING COUNT A			6	
		TRACKING D GAIN			0.0	
	LOW SPEED COG	OUTPUT			OFF	
	MAINTENANCE	DIAGNOSIS	DISPLAY			-
			PROCESSOR			-
			SENSOR1			-
			SENSOR2			-
		MONITOR	DATA IN1			-
			DATA IN2			-
			DATA IN3			-
RS-232C					-	
SWITCH					-	
LAN1					-	
LAN2					-	
SENSOR1					-	
SENSOR2				-		
OPERATING TIME		OPERATING TIME(hr)			-	
		LCD TIME(hr)			-	

MENU	Sub Menu	Sub Menu	Sub Menu	Sub Menu	Range
	RESET				-
	DEMO	DEMO TYPE			STATIC
		START/ STOP			START
		YEAR			00
		MONTH			01
		DAY			01
		HOUR(hr)			00
		MINUTE(min)			00
		SECOND(s)			00
		QUADRANT			NE
		LAT			00° 00.0000'N
		LON			00° 00.0000'N
		SPEED(kn)			10.0
		COURSE(°)			000.0
		RADIUS(NM)			000.1
	ROUTE			001	
	ALL SETTING VALUE	BACKUP INFO			-
		IMPORT/ EXPORT	MPORT/ EXPORT		PROCESSOR →
			PROCESS		DISPLAY BACKUP

Appendix 5 Data Format

Output Sentence

• GGA – Global positioning system (GPS) fix data

\$--GGA, hhmss.ss, llll.ll, a, yyyy.yy, a, x, xx, x.x, x.x, M, x.x, M, x.x, xxxx*hh<CR><LF>
1 2 3 4 5 6 7 8 9 10 11 12

- 1 : UTC of position
- 2 : Latitude N/S
- 3 : Longitude E/W
- 4 : GPS quality indicator (see Note 1)
- 5 : Number of satellites in use, 00-12, maybe different from the number in view
- 6 : Horizontal dilution of precision
- 7 : Antenna altitude above/below mean sea level (geoid)
- 8 : Units of antenna altitude, m
- 9 : Geoidal separation (see Note 3)
- 10 : Units of geoidal separation, m
- 11 : Age of differential GPS data (see Note 2)
- 12 : Differential reference station ID, 0000-1023

NOTE 1 All GPS quality indicators in headings 1 through 8 are considered "valid". The heading "0" is the only "invalid" indicator. The GPS quality indicator field should not be a null field.

0 = fix not available or invalid

1 = GPS SPS mode

2 = differential GPS, SPS mode

8 = Simulator mode

NOTE 2 Time in seconds since last SC104 type 1 or 9 update, null field when DGPS is not used.

NOTE 3 Geoidal separation: the difference between the WGS-84 earth ellipsoid surface and mean sea level (geoid) surface, " - " = mean sea level surface below the WGS-84 ellipsoid surface.

• RMC – Recommended minimum specific GNSS data

\$--RMC, hhmss.ss, A, llll.ll, a, yyyy.yy, a, x.x, x.x, xxxxxx, x.x, a, a, a*hh<CR><LF>
1 2 3 4 5 6 7 8 9 10 11 12 13

- 1 : UTC of position fix
- 2 : Status (see Note 3) A = data valid V = navigation receiver warning
- 3 : Latitude, N/S
- 4 : Latitude, N/S
- 5 : Longitude, E/W
- 6 : Longitude, E/W
- 7 : Speed over ground, knots
- 8 : Course over ground, degrees true
- 9 : Date: dd/mm/yy
- 10 : Magnetic variation, degrees, E/W (see Note 1)
- 11 : Magnetic variation, degrees, E/W (see Note 1)
- 12 : Mode indicator (see Notes 2 and 3)
- 13 : Navigational status (see Note 4)

NOTE 1 E = Easterly variation subtracts from True course
W = Westerly variation adds to True course

NOTE 2 Positioning system Mode Indicator:

A = Autonomous. Satellite system used in non-differential mode in position fix;

D = Differential. Satellite system used in differential mode in position fix;

P = Precise. Satellite system used in precision mode. Precision mode is defined as: no deliberate degradation (such as selective availability) and higher resolution code (P-code) is used to compute position fix. P is also

used for satellite system used in multi-frequency, SBAS or Precise Point Positioning (PPP) mode;
S = Simulator mode.

NOTE 3 The positioning system mode indicator field supplements the positioning system status field, the status field should be set to V = Invalid for all values of indicator mode except for A= Autonomous and D = Differential. The positioning system mode indicator and status fields should not be null fields.

NOTE 4 The navigational status indicator is according to IEC 61108 requirements on 'Navigational (or Failure) warnings and status indications'. This field should not be a NULL field and the character should take one of the following values:

S = Safe when the estimated positioning accuracy (95 % confidence) is within the selected accuracy level corresponding to the actual navigation mode, and/or integrity is available and within the requirements for the actual navigation mode, and/or a new valid position has been calculated within 1 s for a conventional craft and 0,5 s for a high speed craft.

C = Caution when integrity is not available.

U = Unsafe when the estimated positioning accuracy (95 % confidence) is less than the selected accuracy level corresponding to the actual navigation mode, and/or integrity is available but exceeds the requirements for the actual navigation mode, and/or a new valid position has not been calculated within 1 s for a conventional craft and 0,5 s for a high speed craft.

V = Navigational status not valid, equipment is not providing navigational status indication.

• GLL – Geographic position – Latitude/longitude

\$--GLL, llll.ll, a, yyyyy.yy, a, hhmmss.ss, A, a *hh<CR><LF>
1 2 3 4 5 6 7

1 : Latitude, N/S

2 : Latitude, N/S

3 : Longitude, E/W

4 : Longitude, E/W

5 : UTC of position

6 : Status (see Note 2) A=data valid V=data invalid

7 : Mode indicator (see Notes 1 and 2)

NOTE 1 Positioning system mode indicator:

D = Differential

S = Simulator

N = Data not valid

NOTE 2 The mode indicator field supplements the status field (field 6). The status field should be set to V = invalid for all values of operating mode except for A = Autonomous and D = Differential. The positioning system mode indicator and status fields should not be null fields.

• VTG – Course over ground and ground speed

\$--VTG, x.x, T, x.x, M, x.x, N, x.x, K,a*hh<CR><LF>
1 2 3 4 5 6 7 8 9

1 : Course over ground, degrees true

2 : Course over ground, degrees true

3 : Course over ground, degrees magnetic

4 : Course over ground, degrees magnetic

5 : Speed over ground, knots (see Note 1)

6 : Speed over ground, knots (see Note 1)

7 : Speed over ground, km/h (see Note 1)

8 : Speed over ground, km/h (see Note 1)

9 : Mode indicator (see Note 2)

NOTE 1 The speed over the ground should always be non-negative.

NOTE 2 The mode indicator provides status information about the operation of the source device (such as positioning systems, velocity sensors, etc.) generating the sentence, and the validity of data being provided. The possible indications are as follows:

A = Autonomous mode;

D = Differential mode;

P = Precise. Satellite system used in precision mode. Precision mode is defined as: no deliberate degradation (such as selective availability) and higher resolution code (P-code) is used to compute position fix. P is also used for

satellite system used in multi-frequency, SBAS or Precise Point Positioning (PPP) mode;
 S = Simulator mode;
 N = Data not valid.
 The mode indicator field should not be a null field.

• **GSA – GNSS DOP and active satellites**

\$--GSA, a, x, xx,xx,xx,xx,xx,xx,xx,xx,xx,xx,xx,x.x,x.x,x.x,h*hh<CR><LF>
 1 2 3 4 5 6 7

- 1 : Mode: M = manual, forced to operate in 2D or 3D mode
 A = automatic, allowed to automatically switch 2D/3D
- 2 : Mode: 1 = fix not available, 2 = 2D, 3 = 3D
- 3 : ID numbers (see Note 1) of satellites used in solution
- 4 : PDOP
- 5 : HDOP
- 6 : VDOP
- 7 : GNSS System ID (see Note 2)

NOTE 1 Satellite ID numbers. To avoid possible confusion caused by repetition of satellite ID numbers when using multiple satellite systems, the following convention has been adopted.

- a) GPS satellites are identified by their PRN numbers, which range from 1 to 32.
- b) The numbers 33 to 64 are reserved for WAAS satellites. The WAAS system PRN numbers are 120 to 138. The offset from WAAS SV ID to WAAS PRN number is 87. A WAAS PRN number of 120 minus 87 yields the SV ID of 33. The addition of 87 to the SV ID yields the WAAS PRN number.
- c) The numbers 65 to 96 are reserved for GLONASS satellites. GLONASS satellites are identified by 64+satellite slot numbers. The slot numbers are 1 through 24 for the full GLONASS constellation of 24 satellites, thus giving a range of 65 through 88. The numbers 89 through 96 are available if slot numbers above 24 are allocated to on-orbit spares.

NOTE 2 GNSS System ID identifies the GNSS System ID according to the Table below.

• **GSV – GNSS satellites in view**

\$--GSV, x, x, xx, xx, xx, xxx, xx....., xx, xx, xxx, xx, h*hh<CR><LF>
 1 2 3 4 5 6 7 8 9 10

- 1 : Total number of messages (see Note 1), 1 to 9
- 2 : Message number (see Note 1), 1 to 9
- 3 : Total number of satellites in view
- 4 : Satellite ID number (see Note 3)
- 5 : Elevation, degrees, 90° maximum
- 6 : Azimuth, degrees true, 000 to 359
- 7 : SNR (C/No) 00-99 dB-Hz, null when not tracking
- 8 : Second and third SVs (see Note 2)
- 9 : Fourth SV (see Note 2)
- 10 : Signal ID (see Note 4)

NOTE 1 Satellite information may require the transmission of multiple sentences all containing identical field formats when sending a complete message. The first field specifies the total number of sentences, minimum value 1. The second field identifies the order of this sentence (sentence number), minimum value 1. For efficiency it is recommended that null fields be used in the additional sentences when the data is unchanged from the first sentence.

NOTE 2 A variable number of "Satellite ID-Elevation-Azimuth-SNR" sets are allowed up to a maximum of four sets per sentence. Null fields are required for unused sets when less than four sets are transmitted.

NOTE 3 Satellite ID numbers. To avoid possible confusion caused by repetition of satellite ID numbers when using multiple satellite systems, the following convention has been adopted:

- a) GPS satellites are identified by their PRN numbers, which range from 1 to 32.
- b) The numbers 33 to 64 are reserved for WAAS satellites. The WAAS system PRN numbers are 120 to 138. The offset from WAAS SV ID to WAAS PRN number is 87. A WAAS PRN number of 120 minus 87 yields the SV ID of 33. The addition of 87 to the SV ID yields the WAAS PRN number.
- c) The numbers 65 to 96 are reserved for GLONASS satellites. GLONASS satellites are identified by 64+satellite slot number. The slot numbers are 1 through 24 for the full GLONASS constellation of 24 satellites, this gives a range of 65 through 88. The numbers 89 through 96 are available if slot numbers

above 24 are allocated to on-orbit spares.

NOTE 4 Signal ID see Table below.

• DTM – Datum reference

\$--DTM,ccc,a,x.x,a,x.x,a, x.x,ccc*hh<CR><LF>
1 2 3 4 5 6 7 8

1 : Local datum(see Note 1)

WGS84 = W84 / WGS72 = W72 / SGS85 = S85 / PE90 = P90

User defined = 999 / IHO datum code (see Note 4)

2 : Local datum subdivision code (see Note 2)

3 : Lat offset, min, N/S (see Note 3)

4 : Lat offset, min, N/S (see Note 3)

5 : Lon offset, min, E/W (see Note 3)

6 : Lon offset, min, E/W (see Note 3)

7 : Altitude offset, m (see Note 3)

8 : Reference datum (WGS84 = W84 / WGS72 = W72 / SGS85 = S85 / PE90 = P90)

NOTE 1 Three character alpha code for local datum. If not one of the listed earth-centred datums, or 999 for user defined datums, use IHO datum code from International Hydrographic Organisation Publication S-60, Appendices B and C. Null field if unknown. This field should be set to 999 when manual offsets are entered and in use by the position fixing device.

NOTE 2 One character subdivision datum code when available or user defined reference character for user defined datums, null field otherwise. Subdivision character from IHO Publication S-60, Appendices B and C.

NOTE 3 Latitude and longitude offsets are positive numbers, the altitude offset may be negative. Offsets change with position: position in the local datum is offset from the position in the reference datum in the directions indicated:

$$P_{\text{local datum}} = P_{\text{ref datum}} + \text{offset}$$

When field 1 contains a value of 999, these fields may not be null, and should contain the manually entered or user defined offsets.

NOTE 4 Users should be aware that chart transformations based on IHO S60 parameters may result in significant positional errors when applied to chart data.

• GBS – GNSS satellite fault detection

\$--GBS, hhmmss.ss, x.x, x.x, x.x, xx, x.x, x.x, x.x, h, h *hh <CR><LF>
1 2 3 4 5 6 7 8 9 10

1 : UTC time of the GGA or GNS fix associated with this sentence

2 : Expected error in latitude (see Note 1)

3 : Expected error in longitude (see Note 1)

4 : Expected error in altitude (see Note 1)

5 : ID number (see Note 2) of most likely failed satellite

6 : Probability of missed detection for most likely failed satellite

7 : Estimate of bias on most likely failed satellite(in metres)

8 : Standard deviation of bias estimate

9 : GNSS System ID (see Note 3)

10 : GNSS Signal ID (see Note 4)

NOTE 1 Expected error in metres due to bias, with noise = 0.

NOTE 2 Satellite ID numbers. To avoid possible confusion caused by repetition of satellite ID numbers when using multiple satellite systems, the following convention has been adopted (these legacy systems remain in effect for new systems see NOTE 3):

a) GPS satellites are identified by their PRN numbers, which range from 1 to 32.

b) The numbers 33-64 are reserved for WAAS satellites. The WAAS system PRN numbers are 120-138. The offset from WAAS SV ID to WAAS PRN number is 87. A WAAS PRN number of 120 minus 87 yields the SV ID of 33. The addition of 87 to the SV ID yields the WAAS PRN number.

c) The numbers 65-96 are reserved for GLONASS satellites. GLONASS satellites are identified by 64+ satellite slot number. The slot numbers are 1 through 24 for the full GLONASS constellation of 24 satellites; this gives a range of 65 through 88. The numbers 89 through 96 are available if slot numbers above 24 are allocated to on-orbit spares.

NOTE 3 System ID identifies the GNSS System ID according to the Table below. Note that legacy numbering system as above should remain in effect.

NOTE 4 GNSS Signal ID identifies the GNSS Signal ID according to the Table below.

• GRS – GNSS range residuals

\$--GRS, hhmmss.ss,x,h,h *hh<CR><LF>
1 2 3 4 5

- 1 : UTC time of the GGA or GNS fix associated with this sentence
- 2 : Mode: 0 = residuals were used to calculate the position given in the matching GGA or GNS sentence
1 = residuals were re-computed after the GGA or GNS position was computed
- 3 : Range residuals for satellites used in the navigation solution (see Notes 1 and 2)
Order should match order of satellite ID (see Note 3) numbers in GSA.
When GRS is used, GSA and GSV are generally required. Null for unused fields
- 4 : GNSS System ID (see Note 3)
- 5 : Signal ID (see Note 4)

NOTE 1 If the range residual exceeds ± 99.9 m, then the decimal part is dropped, resulting in an integer (-103.7 becomes -103). The maximum value for this field is ± 999 .

NOTE 2 The sense or sign of the range residual is determined by the order of parameters used in the calculation. The expected order is as follows: range residual = calculated range - measured range.

NOTE 3 When multiple GRS sentences are being sent then their order of transmission should match the order of corresponding GSA sentences. Listeners should keep track of pairs of GSA and GRS sentences and discard data if pairs are incomplete.

NOTE 4 Signal ID identifies the actual ranging signal according to the Table below.

NOTE 5 System ID, see Table below.

• GST – GNSS pseudorange noise statistics

\$--GST, hhmmss.ss, x.x, x.x, x.x, x.x, x.x, x.x, x.x*xh<CR><LF>
1 2 3 4 5 6 7 8

- 1 : UTC time of the GGA or GNS fix associated with this sentence
- 2 : RMS value of the standard deviation of the range inputs to the navigation process. Range inputs include pseudoranges and DGPS corrections
- 3 : Standard deviation of semi-major axis of error ellipse (m)
- 4 : Standard deviation of semi-minor axis of error ellipse (m)
- 5 : Orientation of semi-major axis of error ellipse (degrees from true north)
- 6 : Standard deviation of latitude error (m)
- 7 : Standard deviation of longitude error (m)
- 8 : Standard deviation of altitude error (m)

• ZDA – Time and date

\$--ZDA, hhmmss.ss, xx, xx, xxxx, xx, xx*xh<CR><LF>
1 2 3 4 5 6

- 1 : UTC
- 2 : Day, 01 to 31 (UTC)
- 3 : Month, 01 to 12 (UTC)
- 4 : Year (UTC)
- 5 : Local zone hours(see Note), 00 h to ± 13 h
- 6 : Local zone minutes (see Note), 00 to +59

NOTE Local time zone is the magnitude of hours plus the magnitude of minutes added, with the sign of local zone

hours, to local time to obtain UTC. Local zone is generally negative for East longitudes with local exceptions near the international date line.

Example: At Chatham Is. (New Zealand) at 1230 (noon) local time on June 10, 1995:

```
$GPZDA,234500,09,06,1995,-12,45*6C<CR><LF>
```

In the Cook Islands at 1500 local time on June 10, 1995:

```
$GPZDA,013000,11,06,1995,10,30*4A<CR><LF>
```

• GNS – GNSS fix data

```
$-- GNS, hhmss.ss, llll.ll, a, yyyy.yy, a, c--c,xx,x.x,x.x,x.x,x.x,x.x,a *hh<CR><LF>
```

1 2 3 4 5 6 7 8 9 10 11 12 13

- 1 : UTC of position
- 2 : Latitude, N/S
- 3 : Latitude, N/S
- 4 : Longitude, E/W
- 5 : Longitude, E/W
- 6 : Mode indicator (see Note 1)
- 7 : Total number of satellites in use, 00-99
- 8 : HDOP (see Note 3)
- 9 : Antenna altitude, m, re: mean-sea-level (geoid)
- 10 : Geoidal separation, m (see Note 4)
- 11 : Age of differential data (see Note 2)
- 12 : Differential reference station ID (see Note 2)
- 13 : Navigational status indicator (see Note 5)

NOTE 1 Mode indicator. A variable length valid character field type with the first three characters currently defined. The first character indicates the use of GPS satellites, the second character indicates the use of GLONASS satellites and the third indicate the use of Galileo satellites. If another satellite system is added to the standard, the mode indicator will be extended to four characters, new satellite systems should always be added on the right, so the order of characters in the mode indicator is: GPS, GLONASS, Galileo, other satellite systems in the future. The characters should take one of the following values:

A = Autonomous. Satellite system used in non-differential mode in position fix

D = Differential. Satellite system used in differential mode in position fix

N = No fix. Satellite system not used in position fix, or fix not valid

P = Precise. Satellite system used in precision mode. Precision mode is defined as: no deliberate degradation (such as selective availability) and higher resolution code (P-code) is used to compute position fix. P is also used for satellite system used in multi-frequency, SBAS or Precise Point Positioning (PPP) mode

S = Simulator mode

The mode indicator should not be a null field.

NOTE 2 Age of differential data and Differential Reference Station ID:

a) When the talker is GN and more than one of the satellite systems are used in differential mode, then the "Age of differential data" and "Differential reference station ID" fields should be null. In this case, the "Age of differential data" and "Differential reference station ID" fields should be provided in following GNS sentences with talker IDs of GP, GL, etc. These following GNS messages should have the latitude, N/S, longitude, E/W, altitude, geoidal separation, mode, and HDOP fields null. This indicates to the listener that the field is supporting a previous \$GNGNS sentence with the same time tag. The "Number of satellites" field may be used in these following sentences to denote the number of satellites used from that satellite system.

Example: A combined GPS/GLONASS receiver using only GPS differential corrections has the following GNS sentence sent.

```
$GNGNS,122310.2,3722.425671,N,12258.856215,W,DA,14,0.9,1005.543,6.5,5.2,23*59<CR><LF>
```

Example: A combined GPS/GLONASS receiver using both GPS differential corrections and GLONASS differential corrections may have the following three GNS sentences sent in a group.

```
$GNGNS,122310.2,3722.425671,N,12258.856215,W,DD,14,0.9,1005.543,6.5,,*74<CR><LF>
```

```
$GPGNS,122310.2,,,,,7,,,5.2,23*4D<CR><LF>
```

```
$GLGNS,122310.2,,,,,7,,,3.0,23*55<CR><LF>
```

The Differential Reference station ID may be the same or different for the different satellite systems.

b) Age of Differential Data

For GPS Differential Data:

This value is the average age of the most recent differential corrections in use. When only RTCM SC104

Type 1 corrections are used, the age is that of the most recent Type 1 correction. When RTCM SC104

Type 9 corrections are used solely, or in combination with Type 1 corrections, the age is the average of the most recent corrections for the satellites used. Null field when Differential GPS is not used.

NOTE 3 HDOP calculated using all the satellites (GPS, GLONASS, Galileo and any future satellites) used in computing the solution reported in each GNS sentence.

NOTE 4 Geoidal Separation: the difference between the earth ellipsoid surface and mean-sea-level (geoid) surface defined by the reference datum used in the position solution, "-" = mean-sea-level surface below ellipsoid. The reference datum may be specified in the DTM sentence.

NOTE 5 The navigational status indicator is according to IEC 61108 requirements on 'Navigational (or Failure) warnings and status indications'. This field should not be a NULL field and the character should take one of the following values:

S = Safe when the estimated positioning accuracy (95 % confidence) is within the selected accuracy level corresponding to the actual navigation mode, and integrity is available and within the requirements for the actual navigation mode, and a new valid position has been calculated within 1 s for a conventional craft and 0,5 s for a high speed craft

C = Caution when integrity is not available

U = Unsafe when the estimated positioning accuracy (95 % confidence) is less than the selected accuracy level corresponding to the actual navigation mode, and/or integrity is available but exceeds the requirements for the actual navigation mode, and/or a new valid position has not been calculated within 1 s for a conventional craft and 0,5 s for a high speed craft

V = Navigational status not valid, equipment is not providing navigational status indication.

• MSS – MSK receiver signal status

\$--MSS,x.x,x.x,x.x,x.x,x*x*hh<CR><LF>
 1 2 3 4 5

- 1 : Signal strength (SS), dB/1 mV/m
- 2 : Signal-to-noise ratio (SNR), dB
- 3 : Beacon frequency, 283,5 kHz to 325,0 kHz
- 4 : Beacon bit rate (25, 50, 100, 200) bits/s
- 5 : Channel number (see Note)

NOTE Set equal to "1" or null for single channel receivers.

• ALR – Set alarm state

\$--ALR,hhmmss.ss,xxx,A, A,c--c*hh<CR><LF>
 1 2 3 4 5

- 1 : Time of alarm condition change, UTC
- 2 : Unique alarm number (identifier) at alarm source
- 3 : Alarm condition (A = threshold exceeded, V = not exceeded)
- 4 : Alarm's acknowledge state, A = acknowledged / V = unacknowledged
- 5 : Alarm's description text

• APB – Heading/track controller (autopilot) sentence B

\$--APB, A, A, x.x, a, N, A, A, x.x, a, c--c, x.x, a, x.x, a, a*hh<CR><LF>
 1 2 3 4 5 6 7 8 9 10 11 12 13 14 15

- 1 : Status: A = Data valid V = LORAN-C blink or SNR warning (see Note 2)
 V = general warning flag for other navigation systems when a reliable fix is not available
- 2 : Status: A = OK or not used V = LORAN-C cycle lock warning flag (see Note 2)
- 3 : Magnitude of XTE (cross-track-error)
- 4 : Direction to steer, L/R
- 5 : XTE units, nautical miles
- 6 : Status: A = arrival circle entered V = arrival circle not passed
- 7 : Status: A = perpendicular passed at waypoint
 V = perpendicular not entered
- 8 : Bearing origin to destination, M/T
- 9 : Bearing origin to destination, M/T
- 10 : Destination waypoint ID
- 11 : Bearing, present position to destination, magnetic or true
- 12 : Bearing, present position to destination, magnetic or true
- 13 : Heading to steer to destination waypoint, magnetic or true
- 14 : Heading to steer to destination waypoint, magnetic or true

15 : Mode indicator (see Notes 1 and 2)

NOTE 1 Positioning system mode indicator:

A = Autonomous mode;
D = Differential mode;
S = Simulator mode;
N = Data not valid.

NOTE 2 The positioning system mode indicator field supplements the positioning system status fields (fields 1 and 2), the status fields should be set to V = invalid for all values of mode indicator except for A = Autonomous and D = Differential. The positioning system mode indicator should not be null fields.

• **BOD – Bearing origin to destination**

\$--BOD, x.x, T, x.x, M, c--c, c--c*hh<CR><LF>
1 2 3 4 5 6

- 1 : Bearing, degrees true
- 2 : Bearing, degrees true
- 3 : Bearing, degrees magnetic
- 4 : Bearing, degrees magnetic
- 5 : Destination waypoint ID
- 6 : Origin waypoint ID

• **BWC – Bearing and distance to waypoint – Great circle**

\$--BWC, hhmmss.ss, llll.ll, a, yyyy.yy, a, x.x, T, x.x, M, x.x, N, c--c, a*hh<CR><LF>
1 2 3 4 5 6 7 8 9 10 11 12 13

- 1 : UTC of observation
- 2 : Waypoint latitude, N/S
- 3 : Waypoint latitude, N/S
- 4 : Waypoint longitude, E/W
- 5 : Waypoint longitude, E/W
- 6 : Bearing, degrees true
- 7 : Bearing, degrees true
- 8 : Bearing, degrees magnetic
- 9 : Bearing, degrees magnetic
- 10 : Distance, nautical miles
- 11 : Distance, nautical miles
- 12 : Waypoint ID
- 13 : Mode indicator (see Note)

NOTE Positioning system mode indicator:

A = Autonomous mode;
D = Differential mode;
S = Simulator mode;
N = Data not valid.

The mode indicator field should not be a null field.

• **BWR – Bearing and distance to waypoint – Rhumb line**

\$--BWR, hhmmss.ss, llll.ll, a, yyyy.yy, a, x.x, T, x.x, M, x.x, N, c--c, a*hh<CR><LF>
1 2 3 4 5 6 7 8 9 10 11 12 13

- 1 : UTC of observation
- 2 : Waypoint latitude, N/S
- 3 : Waypoint latitude, N/S
- 4 : Waypoint longitude, E/W
- 5 : Waypoint longitude, E/W

- 3 : Magnitude of cross-track error
- 4 : Direction to steer, L/R
- 5 : Units, nautical miles
- 6 : Mode indicator (see Notes 1 and 2)

NOTE 1 Positioning system mode indicator:

A = Autonomous mode;
 D = Differential mode;
 S = Simulator mode;
 N = Data not valid.

NOTE 2 The positioning system mode indicator field supplements the positioning system status fields (fields 1 and 2); the status fields should be set to V = invalid for all values of indicator mode except for A = Autonomous and D = Differential. The positioning system mode indicator and status fields should not be null fields.

• **ZTG – UTC and time to destination waypoint**

\$--ZTG, hhmmss.ss, hhmmss.ss, c--c*hh<CR><LF>
 1 2 3

- 1 : UTC of observation
- 2 : Time-to-go, hh = 00 to 99
- 3 : Destination waypoint ID

• **AAM – Waypoint arrival alarm**

\$--AAM, A, A,x.x, N, c--c*hh<CR><LF>

- 1 : Status: A = arrival circle entered; V = not entered
- 2 : Status: A = perpendicular passed at waypoint; V = not passed
- 3 : Arrival circle radius
- 4 : Units of radius, nautical miles
- 5 : Waypoint ID

• **RTE – Routes**

\$--RTE, x.x, x.x, a, c--c, c--c,..... c--c*hh<CR><LF>
 1 2 3 4 5 6 7 8

- 1 : Total number of sentences being transmitted (see Note 2)
- 2 : Sentence number (see Note 2)
- 3 : Message mode: c = complete route, all waypoints
 w = working route, first listed waypoint is "FROM",
 second is "TO" and remaining are rest of route
- 4 : Route identifier
- 5 : Waypoint identifier
- 6 : Additional waypoint identifiers (see Note 1)
- 7 : Additional waypoint identifiers (see Note 1)
- 8 : Waypoint "n" identifier (see Note 1)

NOTE 1 A variable number of waypoint identifiers, up to "n", may be included within the limits of allowed sentence length. As there is no specified number of waypoints, null fields are not required for waypoint identifier fields.

NOTE 2 A single route may require the transmission of multiple sentences, all containing identical field formats when sending a complex message. The first field specifies the number of sentences, minimum value = 1. The second field identifies the order of this sentence (sentence number), minimum value = 1. For efficiency, it is permitted that null fields be used in the additional sentences when the data is unchanged from the first sentence. (Note that this practice can lead to the incorrect assembly of sentences if there is a high risk of loss of sentence.)

• **WPL – Waypoint location**

\$--WPL, llll.ll, a, yyyyy.yy, a, c--c*hh<CR><LF>
1 2 3 4 5

- 1 : Waypoint latitude, N/S
- 2 : Waypoint latitude, N/S
- 3 : Waypoint longitude, E/W
- 4 : Waypoint longitude, E/W
- 5 : Waypoint identifier

• **ACK – Acknowledge alarm**

\$--ACK,xxx*hh<CR><LF>
1

- 1 : Unique alarm number (identifier) at alarm source

• **ALF – Alert sentence**

\$--ALF, x, x, x, hhhmss.ss, a, a, a, aaa, x.x, x.x, x.x, x, c---c*hh <CR><LF>
1 2 3 4 5 6 7 8 9 10 11 12 13

- 1 : Total number of ALF sentences for this message, 1 to 2
- 2 : Sentence number, 1 to 2
- 3 : Sequential message identifier, 0 to 9
- 4 : Time of last change
- 5 : Alert category, A or B
- 6 : Alert priority, A, W or C
- 7 : Alert state, A, S, N, O, U or V
- 8 : Manufacturer mnemonic code
- 9 : Alert identifier
- 10 : Alert instance, 1 to 999999
- 11 : Revision counter, 1 to 99
- 12 : Escalation counter, 0 to 9
- 13 : Alert text

• **ALC – Cyclic alert list**

\$--ALC, xx, xx, xx, x.x, aaa, x.x, x.x, x.x,.....,aaa, x.x, x.x, x.x*hh <CR><LF>
1 2 3 4 5 6 7 8 9

- 1 : Total number of sentences for this message, 01 to 99
- 2 : Sentence number, 01 to 99
- 3 : Sequential message identifier, 00 to 99
- 4 : Number of alert entries
- 5 : Manufacturer mnemonic code
- 6 : Alert identifier
- 7 : Alert instance
- 8 : Revision counter
- 9 : Additional Alert entries 5~8

• **ARC – Alert command refused**

\$--ARC, hhmmss.ss, aaa, x.x, x.x, c*hh <CR><LF>
1 2 3 4 5

- 1 : Time
- 2 : Manufacturer mnemonic code
- 3 : Alert identifier
- 4 : Alert instance, 1 to 999999
- 5 : Refused alert command, A, Q, O or S

• **AGL – Alert group list**

\$--AGL, xx, xx, xx, c---c, ccc, x.x, x.x, ...,c---c, ccc, x.x, x.x*hh<CR><LF>
1 2 3 4 5 6 7 8

- 1 : Total number of sentences for this message
- 2 : Sentence number
- 3 : Sequential message identifier, 00 to 99
- 4 : SFI of alert source
- 5 : Manufacturer mnemonic code
- 6 : Alert identifier
- 7 : Alert instance
- 8 : Additional alert entries 4~7

• **HBT – Heartbeat supervision sentence**

\$--HBT, x.x, A, x*hh<CR><LF>
1 2 3

- 1 : Configured repeat interval
- 2 : Equipment status
- 3 : Sequential sentence identifier

• **HDT – Heading true**

\$--HDT, x.x, T*hh<CR><LF>
1 2

- 1 : Heading, degrees true
- 2 : Heading, degrees true

• **THS – True heading and status**

\$--THS,x.x,a*hh<CR><LF>
1 2

- 1 : Heading, degrees true
- 2 : Mode indicator (see Note)

NOTE Mode indicator. This field should not be null.

A = Autonomous

S = Simulator mode

V = Data not valid (including standby)

• **DBT – Depth below transducer**

\$--DBT, x.x, f, x.x, M, x.x, F*hh<CR><LF>
1 2 3 4 5 6

- 1 : Water depth, feet
- 2 : Water depth, feet
- 3 : Water depth, m
- 4 : Water depth, m
- 5 : Water depth, fathoms
- 6 : Water depth, fathoms

• **DPT – Depth**

\$--DPT, x.x, x.x, x.x*hh<CR><LF>
1 2 3

- 1 : Water depth relative to the transducer, in metres
- 2 : Offset from transducer, in metres (see Notes 1 and 2)
- 3 : Maximum range scale in use

NOTE 1 "positive" = distance from transducer to water line; "-" = distance from transducer to keel.

NOTE 2 For IEC applications, the offset should always be applied so as to provide depth relative to the keel.

• **MTW – Water temperature**

\$-- MTW, x.x, C*hh<CR><LF>
1 2

- 1 : Temperature, degrees C
- 2 : Temperature, degrees C

• **CUR – Water current layer – Multi-layer water current data**

\$--CUR,A,x,x,x,x,x,x,a,x,x,x,x,x,a,a*hh<CR LF>
1 2 3 4 5 6 7 8 9 10 11

- 1 : Validity of the data, A = Valid, V = not valid
- 2 : Data set number, 0 to 9 (see Note 1)
- 3 : Layer number (see Note 2)
- 4 : Current depth in metres
- 5 : Current direction in degrees
- 6 : Direction reference in use, True/Relative T/R
- 7 : Current speed in knots
- 8 : Reference layer depth in metres (see Note 3)
- 9 : Heading
- 10 : Heading reference in use, True/Magnetic T/M
- 11 : Speed reference (see Note 4)
 - B: Bottom track
 - W: Water track
 - P: Positioning system

NOTE 1 The data set number is used to identify multiple sets of current data produced in one measurement instance. Each measurement instance may result in more than one sentence containing current data measurements at different layers, all with the same data set number. This is used to avoid the data measured in another instance to be accepted as one set of data.

NOTE 2 The layer number identifies which layer the current data measurements were made from. The number of layers that can be measured varies by device. The typical number is between 3 and 32, though many more are possible.

NOTE 3 The current of each layer is measured according to this reference layer, when the speed reference field is set to "water track", or the depth is too deep for bottom track.

NOTE 4 "Speed reference" identifies the method of ship speed used for measuring the current speed.

• VBW – Dual ground/water speed

\$--VBW, x.x, x.x, A, x.x, x.x, A, x.x, A, x.x, A*hh<CR><LF>
1 2 3 4 5 6 7 8 9 10

- 1 : Longitudinal water speed (see Note 1), knots
- 2 : Transverse water speed (see Note 1), knots
- 3 : Status (see Note 2): water speed, A = data valid, V = data invalid
- 4 : Longitudinal ground speed (see Note 1), knots
- 5 : Transverse ground speed (see Note 1), knots
- 6 : Status (see Note 2), ground speed, A = data valid, V = data invalid
- 7 : Stern transverse water speed (see Note 1), knots
- 8 : Status (see Note 2): stern water speed, A = data valid, V = data invalid
- 9 : Stern transverse ground speed (see Note 1), knots
- 10 : Status (see Note 2): stern ground speed, A = data valid, V = data invalid

NOTE 1 Transverse speed: "-" = port,
Longitudinal speed: "-" = astern.

NOTE 2 The status field should not be a null field.

• VHW – Water speed and heading

\$--VHW, x.x, T, x.x, M, x.x, N, x.x, K*hh<CR><LF>
1 2 3 4 5 6 7 8

- 1 : Heading, degrees true
- 2 : Heading, degrees true
- 3 : Heading, degrees magnetic
- 4 : Heading, degrees magnetic
- 5 : Speed, knots
- 6 : Speed, knots
- 7 : Speed, km/h
- 8 : Speed, km/h

Input Sentence

• HDT – Heading true

\$--HDT, x.x, T*hh<CR><LF>
1 2

1 : Heading, degrees true

2 : Heading, degrees true

• THS – True heading and status

\$--THS,x.x,a*hh<CR><LF>
1 2

1 : Heading, degrees true

2 : Mode indicator (see Note)

NOTE Mode indicator. This field should not be null.

A = Autonomous

S = Simulator mode

V = Data not valid (including standby)

• DBT – Depth below transducer

\$--DBT, x.x, f, x.x, M, x.x, F*hh<CR><LF>
1 2 3 4 5 6

1 : Water depth, feet

2 : Water depth, feet

3 : Water depth, m

4 : Water depth, m

5 : Water depth, fathoms

6 : Water depth, fathoms

• DPT – Depth

\$--DPT, x.x, x.x, x.x*hh<CR><LF>
1 2 3

1 : Water depth relative to the transducer, in metres

2 : Offset from transducer, in metres (see Notes 1 and 2)

3 : Maximum range scale in use

NOTE 1 "positive" = distance from transducer to water line; "-" = distance from transducer to keel.

NOTE 2 For IEC applications, the offset should always be applied so as to provide depth relative to the keel.

• MTW – Water temperature

\$-- MTW, x.x, C*hh<CR><LF>
1 2

1 : Temperature, degrees C

2 : Temperature, degrees C

• **CUR – Water current layer – Multi-layer water current data**

\$--CUR,A,x,x,x,x,x,x,a,x,x,x,x,x,a*hh<CR LF>
 1 2 3 4 5 6 7 8 9 10 11

- 1 : Validity of the data, A = Valid, V = not valid
- 2 : Data set number, 0 to 9 (see Note 1)
- 3 : Layer number (see Note 2)
- 4 : Current depth in metres
- 5 : Current direction in degrees
- 6 : Direction reference in use, True/Relative T/R
- 7 : Current speed in knots
- 8 : Reference layer depth in metres (see Note 3)
- 9 : Heading
- 10 : Heading reference in use, True/Magnetic T/M
- 11 : Speed reference (see Note 4)
 - B: Bottom track
 - W: Water track
 - P: Positioning system

NOTE 1 The data set number is used to identify multiple sets of current data produced in one measurement instance. Each measurement instance may result in more than one sentence containing current data measurements at different layers, all with the same data set number. This is used to avoid the data measured in another instance to be accepted as one set of data.

NOTE 2 The layer number identifies which layer the current data measurements were made from. The number of layers that can be measured varies by device. The typical number is between 3 and 32, though many more are possible.

NOTE 3 The current of each layer is measured according to this reference layer, when the speed reference field is set to "water track", or the depth is too deep for bottom track.

NOTE 4 "Speed reference" identifies the method of ship speed used for measuring the current speed.

• **VBW – Dual ground/water speed**

\$--VBW, x.x, x.x, A, x.x, x.x, A, x.x, A, x.x, A*hh<CR><LF>
 1 2 3 4 5 6 7 8 9 10

- 1 : Longitudinal water speed (see Note 1), knots
- 2 : Transverse water speed (see Note 1), knots
- 3 : Status (see Note 2): water speed, A = data valid, V = data invalid
- 4 : Longitudinal ground speed (see Note 1), knots
- 5 : Transverse ground speed (see Note 1), knots
- 6 : Status (see Note 2), ground speed, A = data valid, V = data invalid
- 7 : Stern transverse water speed (see Note 1), knots
- 8 : Status (see Note 2): stern water speed, A = data valid, V = data invalid
- 9 : Stern transverse ground speed (see Note 1), knots
- 10 : Status (see Note 2): stern ground speed, A = data valid, V = data invalid

NOTE 1 Transverse speed: "-" = port,
 Longitudinal speed: "-" = astern.

NOTE 2 The status field should not be a null field.

• **VHW – Water speed and heading**

\$--VHW, x.x, T, x.x, M, x.x, N, x.x, K*hh<CR><LF>
1 2 3 4 5 6 7 8

- 1 : Heading, degrees true
- 2 : Heading, degrees true
- 3 : Heading, degrees magnetic
- 4 : Heading, degrees magnetic
- 5 : Speed, knots
- 6 : Speed, knots
- 7 : Speed, km/h
- 8 : Speed, km/h

• **RTE – Routes**

\$--RTE, x.x, x.x, a, c--c, c--c,..... c--c*hh<CR><LF>
1 2 3 4 5 6 7 8

- 1 : Total number of sentences being transmitted (see Note 2)
- 2 : Sentence number (see Note 2)
- 3 : Message mode: c = complete route, all waypoints
w = working route, first listed waypoint is "FROM",
second is "TO" and remaining are rest of route
- 4 : Route identifier
- 5 : Waypoint identifier
- 6 : Additional waypoint identifiers (see Note 1)
- 7 : Additional waypoint identifiers (see Note 1)
- 8 : Waypoint "n" identifier (see Note 1)

NOTE 1 A variable number of waypoint identifiers, up to "n", may be included within the limits of allowed sentence length. As there is no specified number of waypoints, null fields are not required for waypoint identifier fields.

NOTE 2 A single route may require the transmission of multiple sentences, all containing identical field formats when sending a complex message. The first field specifies the number of sentences, minimum value = 1. The second field identifies the order of this sentence (sentence number), minimum value = 1. For efficiency, it is permitted that null fields be used in the additional sentences when the data is unchanged from the first sentence. (Note that this practice can lead to the incorrect assembly of sentences if there is a high risk of loss of sentence.)

• **WPL – Waypoint location**

\$--WPL, llll.ll, a, yyyy.yy, a, c--c*hh<CR><LF>
1 2 3 4 5

- 1 : Waypoint latitude, N/S
- 2 : Waypoint latitude, N/S
- 3 : Waypoint longitude, E/W
- 4 : Waypoint longitude, E/W
- 5 : Waypoint identifier

• **ACK – Acknowledge alarm**

\$--ACK,xxx*hh<CR><LF>
1

- 1 : Unique alarm number (identifier) at alarm source

• **ALR – Set alarm state**

\$--ALR,hhmmss.ss,xxx,A, A,c--c*hh<CR><LF>
1 2 3 4 5

- 1 : Time of alarm condition change, UTC
- 2 : Unique alarm number (identifier) at alarm source
- 3 : Alarm condition (A = threshold exceeded, V = not exceeded)
- 4 : Alarm's acknowledge state, A = acknowledged / V = unacknowledged
- 5 : Alarm's description text

• **ACN – Alert command**

\$--ACN, hhmmss.ss, aaa, x.x, x.x, c, a*hh <CR><LF>
1 2 3 4 5 6

- 1 : Time
- 2 : Manufacturer mnemonic code
- 3 : Alert Identifier
- 4 : Alert Instance, 1 to 999999
- 5 : Alert command, A, Q, O or S
- 6 : Sentence status flag, fixed C

Appendix 6 Compass Safe Distance

No	Name	Model	Compass Safe Distance [m]	
			Standard	Steering
1	Dimmer	NCM-227	0.1	0.1
2	Printer	NKG-104	0.8	0.5
3	Select Switch	NCZ-777	0.2	0.1
4	Select Switch	NCZ-1663	0.1	0.1
5	Select Switch	NCZ-1537B	0.2	0.1
6	Junction Box	NQE-7700A	0.2	0.1
7	Output Buffer	NQA-4251A	0.1	0.1
8	Output Buffer	NQA-4351	0.1	0.1
9	Junction Box (note 1)	NQD-4410	0.2	0.1
10	Junction Box (note 1)	NQD-4411	0.2	0.1
11	Junction Box	CQD-10	0.3	0.2

note 1) Coaxial Cable Kit NQD-4414: consisting of NQD-4410 and NQD-4411

Appendix 7 About Chinese version RoHS

Declaration on hazardous substances of Electrical and electronic Products Japan Radio Company Limited

有害物质的名称及含量 (Names & Content of hazardous substances)

形式名(Type): JLR-8600

名称(Name): GPS Navigator

部件名称 (Part name)	有害物质 (Hazardous Substances)					
	铅 (Pb)	汞 (Hg)	镉 (Cd)	六价铬 (Cr(VI))	多溴联苯 (PBB)	多溴二苯醚 (PBDE)
室外装置 (Externally Mounted Equipment)	×	×	×	×	×	×
室内装置 (Internally Mounted Equipment)	×	×	×	×	×	×
外部设备(Peripherals) · 打印机(Printer) · 选择(Options) · 电线类(Cables) · 手册/Documents)	×	×	×	×	×	×

本表格依据SJ/T 11364 的规定编制。
(This table is prepared in accordance with the provisions of SJ/T 11364.)

○: 表示该有害物质在该部件所有均质材料中的含量均在GB/T 26572 标准规定的限量要求以下。
(Indicates that this hazardous substance contained in all of the homogeneous materials for this part is below the requirement in GB/T 26572.)

×: 表示该有害物质至少在该部件的某一均质材料中的含量超出GB/T 26572 标准规定的限量要求。
(Indicates that this hazardous substance contained in at least one of the homogeneous materials used for this part is above the limit requirement in GB/T 26572.)

RE: 中华人民共和国电器电子产品有害物质限制使用管理办法
Measures for the Administration of the Restricted Use of the Hazardous Substances Contained in Electrical and Electronic Products of the People's Republic of China

アスベストは使用していません
Not use the asbestos

For further information, contact:

JRC *Japan Radio Co., Ltd.*

Since 1915

URL Head office : <http://www.jrc.co.jp/eng/>

Marine Service Department

1-7-32 Tatsumi, Koto-ku, Tokyo 135-0053, Japan

e-mail : tmsc@jrc.co.jp

One-call : +81-50-3786-9201

ISO 9001, ISO 14001 Certified

CODE No.7ZPNA4699

MAY. 2021 Edition 2