

JAX-9B

WEATHER FACSIMILE RECEIVER

INSTRUCTION MANUAL



JRC *Japan Radio Co., Ltd.*

Thank you very much for purchasing the JRC JAX-9B Weather Facsimile Receiver.

JAX-9B is designed to receive FAX broadcasting such as weather charts and marine charts transmitted in a high frequency band (2 to 25MHz) and record those on recording paper.



- Read this *Instruction Manual* carefully before attempting to operate JAX-9B to ensure your Weather Facsimile Receiver provide optimum satisfaction and service.
- We recommend you to carefully store this *Instruction Manual* for the future reference.
- Please utilize it, if you have any problems using this product.

Before Operation

Pictorial Indication

In this *Instruction Manual* and on the product, we use various pictorial indications to handle the product safely and correctly and to prevent you from harming yourself and other people or damaging those properties beforehand.

Meanings of the indications are shown below. Understand the meanings of signs before proceeding to read the main text.

	DANGER	This indication is shown where any person is supposed to be in danger of being killed or seriously injured if this indication is neglected or equipment is not operated correctly.
	WARNING	This indication is shown where any person is supposed to be in danger of being killed or seriously injured if this indication is neglected or equipment is not operated correctly.
	CAUTION	This indication is shown where any person is supposed to be injured or any property damage is supposed to occur if this indication is neglected or equipment is not operated correctly.

Examples of Pictorial Indication

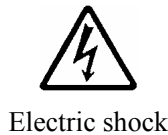

△ marks indicate CAUTION (including DANGER and WARNING). Detailed contents of CAUTION (“Electric Shock” in the example on left) are shown in the mark.



⊘ marks indicate prohibition. Detailed contents of prohibited actions (“Disassembling Prohibited” in the example on left) are shown in the mark.



● marks indicate a specific action that must be followed or instruction. Detailed contents of instructions (“Disconnect the power plug” in the example on left) are shown in the mark.

WARNING



Do not disassemble or remodel this equipment.
Such action may cause a fire, electric shock, or malfunction of the equipment.



Do not use any power supply voltage other than the specified one.
Such an action may cause a fire, an electric shock, or equipment malfunction.



Turn off power supply switch before connecting or disconnecting cables to any external equipment. Not turning it off may cause a fire or an electric shock.



If the power supply cable is damaged, ask for the replacement to the sales department of Japan Radio Co., Ltd (JRC), a nearby branch office, business office, or any agents of JRC.
The use of damaged cables may cause a fire or an electric shock.



If water enters into the equipment, shut off the power, disconnect the plug from the outlet, and contact the sales department of JRC, a nearby branch office, business office, or any agents of JRC. Using it as it is may cause a fire, electric shock, or malfunction.



Do not attempt inspections or repairs on the internal part of the equipment by yourself.
Inspections or repairs by anyone other than qualified maintainers may cause a fire or electric shock. Ask for internal inspections or repairs of the equipment to the sales department of JRC, a nearby branch office, business office, or any agents of JRC.



If equipment malfunctions, shut off its power and contact the sales department of JRC, a nearby branch office, business office, or any agents of JRC. The continuous use of the equipment may cause a fire or electric shock.



Never replace the back-up battery by yourself.
Replacement by anyone other than qualified maintainers may cause a fire, an electric shock, or a malfunction.
For the back-up battery replacement, contact the sales department of JRC, a nearby branch office, business office, or any agents of JRC.

Precautions

WARNING



When disposing of this unit, abide by local laws and regulations. For lithium battery, however, contact the sales department of JRC, a nearby branch office, business office, or any agents of JRC without discarding it as it is.



Do not insert or drop any foreign objects such as metallic pieces into an air vent or opening. Otherwise, it may cause a fire, electric shock or malfunction.



If anything abnormal such as smoke, strange smell or unusual heat is emitted, shut OFF the POWER switch of the equipment immediately and pull the power cable out of power supply unit. Then, contact the sales department of JRC, a nearby branch office, business office, or any agents of JRC. The continued use of the equipment may cause a fire or electric shock.



Be careful not to allow any wire dust or metallic pieces to get into the inside of JAX-9B. Otherwise, it may cause a fire, electric shock, or malfunction.

CAUTION



Do not install the equipment on the location where infringed by water, humidity, steam, dust, or soot. Otherwise, it may cause a fire, electric shock, or malfunction.



Do not touch the equipment if your hands or gloves are wet either with freshwater or seawater. Otherwise, it may cause an electric shock, or a malfunction.



Be sure to hold power supply plug when pulling it out of outlet. Pulling the power cable without holding the plug can damage the cable and may cause a fire or an electric shock.



Do not connect or disconnect the power supply cable with wet hands. Otherwise, it may cause an electric shock.



If the equipment is splashed either with seawater or fresh water, wipe it dry immediately. Otherwise, it may cause a failure or operational malfunctions.

CAUTION



Do not use organic solvents such as thinner or benzene to clean the surface. These agents can damage the surface coating. Remove dirt and dust on the surface if any and wipe it with a clean dry cloth.



Use the recording paper (6ZPTS00108) as specified by JRC.
The use of any other unspecified paper may cause recording density blurs, abnormal paper feed, much dust, resulting in the damage of the recording device.



Connect the earth line to the earth terminal firmly.
Otherwise, it may cause an electric shock when the equipment has a failure or electric leak.



Do not rub the heating element (contacting with the paper) in the recording device with a screwdriver, file or any other hard objects.
Otherwise, it destroys the recording device.



Do not store recording papers in the place exposed to a high temperature, high humidity or direct sunlight. Otherwise, it may cause recording density blurs.



Do not connect the power cable to the common power outlet with any other cables with high power noise (such as for an air conditioner). Otherwise, it may cause a receiving interference.



Do not install the equipment on the unstable place such as on the shaky stand or inclined surface. Otherwise, it may drop or fall down, resulting in an injury or malfunction.



Do not install the equipment under the direct sunlight.
The high temperature may discolor the recording paper or cause an equipment malfunction.



Do not install the equipment near any other radio equipment.
Otherwise, it may cause a receiving disturbance.



Do not bring the equipment in the cooled state suddenly to a high-temperature room.
Otherwise, the air inside the equipment may be condensated, resulting in a malfunction.

Precautions

CAUTION



Turn on or off the POWER switch after waiting more than one second.
Turning it back ON right after being turned OFF in no time may cause the equipment malfunction.



Clean the thermal head with a piece of soft cloth always. Do not rub it with a screw driver or file. Otherwise, it destroys the thermal head.



Do not replace the backup battery by customers.
Even if the POWER switch on the equipment is turned OFF, some parts may remain electrically charged, causing an electric shock or malfunction.
Request replacing the backup battery to the sales department of JRC, a nearby branch office, business office, or any agents of JRC.



Use the JRC-specified backup battery (CR2032-type lithium battery).
The use of any unspecified battery may cause a malfunction or failure of the equipment.



The prohibited matters over lithium battery are as follows;
• Short-circuit of electrodes, • Any unspecified uses of battery, •Decomposing, •Converting, • Discarding, •Throwing into the fire, •Heating, • Use of battery that passes exchange time.
Otherwise, these may cause following trouble;
• Electrolyte leakage, •Generation of Heat, •Fire •Explosion, •Destruction, •Burn



In returning used lithium battery to JRC, take the insulating treatment such as attaching a tape to the +/- terminals. If the battery is short-circuited with no insulating treatment, it may cause a heat, explosion or fire.



Do not conduct operations with wet hands.
Otherwise, it may cause an electric shock.



Turn off power supply switch before opening the top cover to replace the recording paper.
Otherwise, it may cause an electric shock, malfunction, or burn.

JAX-9B Weather Facsimile Receiver External Appearance



Contents

Contents

Preface	i
Before Operation	ii
Precautions	iii
Equipment Appearance	vii
Glossary	xi
Chapter 1 General Outline of Equipment	1
1.1 Function	1
1.2 Features.....	1
1.2.1 Various Recording Modes	1
1.2.2 16-gradation Halftone Recording	1
1.2.3 Fine-line Compensation Circuit.....	1
1.2.4 Synthesizer-based Receiver Capable of Storing 90 Frequencies	1
1.2.5 Automatic Frequency Selection	2
1.2.6 Internal Clock.....	2
1.2.7 Automatic Time Correction.....	2
1.2.8 Remote Maintenance Function.....	2
1.2.9 Displaying Received Image on PC (Option)	2
1.3 Components.....	3
1.4 Outline Drawings.....	4
1.5 System Diagram (220Vac)	5
Chapter 2 Names and Functions	7
2.1 Power Switch	7
2.2 Operation Panel.....	7
2.2.1 Operation of switches.....	8
2.2.2 Display	10
2.3 Control Dials.....	11
2.4 Button for Opening a Cover of Recording Paper.....	11
2.5 LCD Display	12
2.5.1 Startup	12
2.5.2 During Recording	13
2.5.3 Display contents.....	13
Chapter 3 Installation.....	15
3.1 Installation Procedure.....	16
3.2 Precautions for Installation	18
3.3 Changing Display Language.....	19

3.4	Connection of GPS Receiver	20
3.5	Remote Maintenance Function	20
3.6	Optional Function	20
3.7	Installation Drawing	21
3.8	Connection of Cables	22
3.8.1	Wiring of Standard Configurations	22
3.8.2	Power Supply Wiring When Connecting to AC Power Supply (Option).....	23
3.8.3	Connecting to Personal Computer (Option).....	24
 Chapter 4 Operation		25
4.1	Selection and Setting of Receiving Frequency (Automatic Frequency Selection)	26
4.1.1	Setting Receiving Frequency	26
4.1.2	Automatic Frequency Selection Function.....	27
4.2	Recording Modes	29
4.3	Reception of Facsimile Broadcasting	32
4.3.1	Turning on the Power.....	32
4.3.2	Setting Receiving Frequencies	33
4.3.3	Setting Recording Mode.....	37
4.4	Registration of Frequency Channel	42
4.4.1	Registering Frequency Channels	43
4.4.2	Deleting Registered Frequencies.....	45
4.4.3	Printing List of Registered Frequency	47
4.5	Timer Program Recording (Registration)	48
4.5.1	Registration Timer Program	49
4.5.2	Setting Power Switch to Timer Mode.....	52
4.5.3	Verifying Timer Program	53
4.5.4	Modifying Timer Program	54
4.5.5	Deleting Timer Program	55
4.5.6	Printing List of Timer Program.....	56
4.6	Additional Functions in Accordance with Broadcasting and Reception.....	57
4.6.1	Adjustment of Inclined Recorded Image.....	58
4.6.2	Half-tone Recording.....	59
4.6.3	Reverse Recording of Black/White	60
4.6.4	Paper Feed.....	60
4.6.5	Attenuator to Internal Receiver.....	61
4.6.6	Fine Tuning of Receiving Frequency (UP / DOWN).....	62
4.6.7	Switching to External Receiver.....	63
4.7	Necessary Functions for Normal Operation of Facsimile	64
4.7.1	Setting Internal Clock	65
4.7.2	Adjusting Brightness of Operation Panel.....	66
4.7.3	Language (English / Japanese) on the LCD.....	66
4.7.4	Program Version Display	67
4.8	Alarm Indications	68
4.8.1	No Recording Paper.....	69
4.8.2	BK Signal Input.....	69

Contents

4.8.3	Life of Backup Battery (Clock Error)	70
Chapter 5	Maintenance	71
5.1	Replacing Recording Paper	71
5.2	Cleaning	74
5.3	Replacing Backup Battery	75
5.4	Troubleshooting	76
Chapter 6	Connection of GPS Receiver	79
6.1	GPS Receiver Connection Interface	79
6.2	Operation Check	80
Chapter 7	The Viewer Software (Optional)	81
7.1	Features	81
7.1.1	Real time image display and automatic file saving	81
7.1.2	Image file management and file opening	81
7.1.3	Operation without the recording paper	81
7.1.4	Printing the image	81
7.1.5	Registration of settings	81
7.2	Option Kit	82
7.3	Setting Up Options	82
Chapter 8	Operating Environment	83
Chapter 9	Customer Support	85
Chapter 10	Disposal	89
10.1	Disposal of the Equipment	89
10.2	Disposal of Used Battery	89
10.3	About the China RoHS	90
Chapter 11	Specifications	91
11.1	Facsimile Functional Ability	91
11.2	Synthesized Receiver	92
11.3	General Specifications	92
11.4	Environmental Condition	92
Appendix		93

Scanning When a facsimile broadcasting is received and recorded, the recording of the received image starts one dot by one dot from the left end of the paper. When the recording reaches the right end, it is returned to the left end of the paper again and the same operation is repeated until the image recording is completed. This operation is called “scanning”.

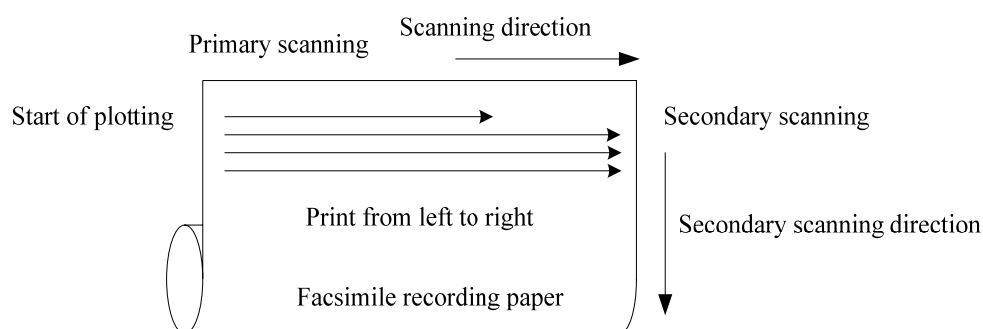

Primary scanning Scanning in the horizontal direction as shown above

Secondary scanning Scanning in the vertical direction as shown above

Scan line density The number of scan lines plotted while the paper moves one millimeter in the secondary scanning direction during the recording of received signals.

Scan speed Primary scanning speed: for example, 120 primary scanings per minute are performed at 120 spm (scan per minute).

Index of cooperation (IOC) If the paper size transmitted from a broadcasting station is different from the recording paper size on the receiving side, it is necessary to equal the vertical and horizontal reduction or enlargement of the original paper to keep a similar figure. The coefficient to keep a similar figure between transmitting and receiving sides is called “index of cooperation”.

Halftone recording This is a method of displaying the contrast of clouds in recording cloud photos taken by a meteorological satellite, in which the contrast is displayed by the difference in the density of black dots like in a black/white photo in a newspaper. It is indicated as HALF in this manual.

Start signal Start signal is the signal transmitted at the beginning of the facsimile broadcasting to indicate the start of the broadcast. JAX-9B uses it for the automatic setting of the index of cooperation (IOC) and starts the automatic recording by receiving this signal.

Glossary

- Phase signal** Phase signal is the signal transmitted next to the start signal. It is indicated at the both ends of the image when synchronization is made. It is used for the automatic setting of scan speed and it is an essential signal used for the automatic recording (AUTO), manual recording (MANU), and timer program recording.
- Similar phase signal** Similar phase signal appears at the same position as the phase signal in the image signal. Depending on broadcasting stations, it may not be included in the image signal. In JAX-9B, this signal is used for phase matching in the manual recording and forced recording.

Chapter 1 General Outline of Equipment

1.1 Function

JAX-9B is capable of receiving facsimile broadcasting such as weather charts and marine charts transmitted in the high-frequency band (2 to 25MHz) and records them on the recording paper.

1.2 Features

1.2.1 Various Recording Modes

1) Automatic recording mode (AUTO)

In the AUTO mode, all operations such as startup, various settings, image recording, paper feed, and stop of recording are automatically performed by the remote signals from the broadcasting station. However, the halftone recording is manually controlled.

2) Manual recording mode (MANU)

In the MANU mode, the index of cooperation (IOC), scan speed and halftone are manually controlled, though the recording and stop are performed automatically.

3) Forced recording mode (# REC)

When the equipment is in any other mode than the mode 1) or 2) (e.g. midway during broadcasting), received images can forcedly be recorded manually as an extension of the MANU mode.

4) Programmed recording mode (TIMER)

JAX-9B can perform unattended operations linked with the internal timer built in its main body by programming the program channel, start and stop times, startup mode, recording frequency and halftone recording.

1.2.2 16-gradation Halftone Recording

Cloud photos received from a weather satellite can be recorded in 16-gradation halftone contrast.

1.2.3 Fine-line Compensation Circuit

The equipment adopts the JRC's original system that can clearly reproduce fine lines in maps and latitude and longitude grids.

1.2.4 Synthesizer-based Receiver Capable of Storing 90 Frequencies

Receiving frequencies can freely be preset from a ten-key pad and up to 90 frequencies (There are 10 groups and 1 group can store 9 frequencies.) can be stored in the internal memory.

In addition, the preset frequencies can be swapped with others on the spot, allowing swift response to any new broadcast or frequency changes.

1.2.5 Automatic Frequency Selection

A frequency with the best receiving condition can be automatically selected among 9 frequencies in the same group. This function can demonstrate a superior effect in timer program recording because it is not necessary to search a frequency with a good receiving condition.

1.2.6 Internal Clock

The equipment incorporates an internal clock as a timer for programmed recording, which indicates time.

1.2.7 Automatic Time Correction

By connecting a GPS receiver, the internal clock can be corrected automatically.

1.2.8 Remote Maintenance Function

The state of JAX-9B can be monitored from the remote place by connecting JAX-9B with our VDR for remote maintenance.

1.2.9 Displaying Received Image on PC (Option)

JAX-9B outputs received image data to a Personal Computer. The PC is able to display a received image.

1.3 Components

Table of Components for Weather Facsimile Receiver

No.	Name	Type	Quantity	Mass 1Unit (kg)	Remarks
Standard Components					
1	Weather facsimile receiver	JAX-9B	1	5.3	with a recording paper roll for testing
2	Protective cover	MTT312734	1	0.08	
3	Coaxial connector	M-P-7	1	0.02	for antenna cable
4	Power supply cable	7ZCNA4046	1	0.3	Cable for DC power supply
5	External I/F cable	7ZCNA4047	1	0.2	Cable for AF signal, BK signal and GPS data
6	RMS cable	7ZCNA4099	1	0.3	Cable for JRC Remote maintenance system or FAX image display PC.
7	Label in Japanese	MPNN32192	1	0.01	Switch name label for Japanese
8	Spare parts	7ZXNA4003	1	0.04	Fuse (5A, 8A) Four pieces each
9	Instruction Manual	7ZPNA4036D	1	0.3	with Operation Card (7ZPNA4103)
Options					
10	Rectifier unit	NBA-5143	1	3.5	
11	FAX image display kit	7ZZNA4017	1	1	PC software for displaying image Communication I/F Unit
12	Viewer Software Instruction Manual	7ZPNA4124C	1	0.2	English
13	Junction box	JQD-69C	1	1	Cable insertion 12mm diameters
14	Whip antenna (L=6MT)	NAW-60	1	3.5	6m
15	Recording paper	6ZPTS00108	_____	0.4	

NOTE

- JAX-9B is shipped with a test recording paper roll and the antenna connector fitted in it.
- The rectifier unit makes 100VAC or 220VAC power supply available to JAX-9B.

1.4 Outline Drawings

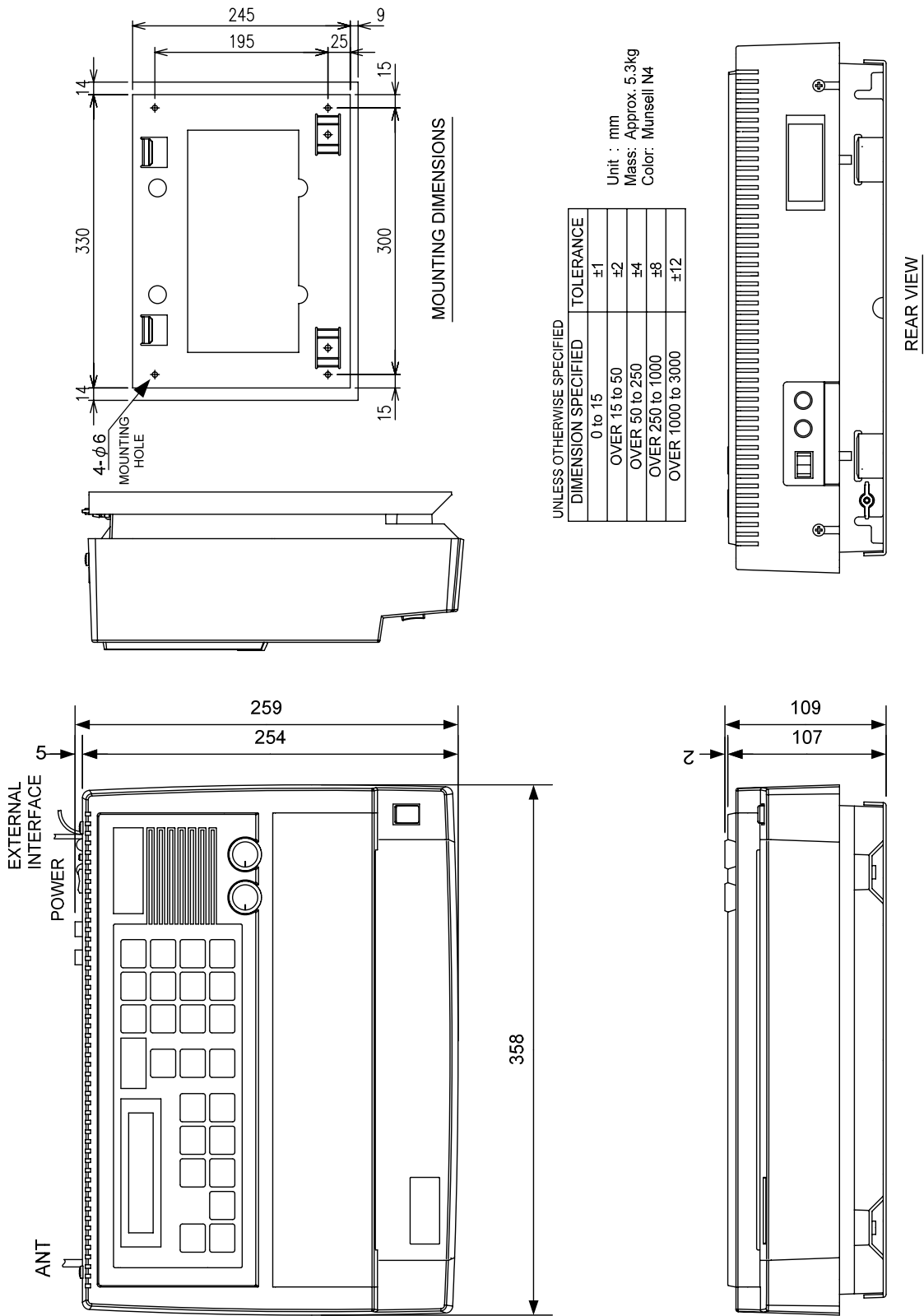

JAX-9B Dimensions (Outline Drawing)

1.5 System Diagram (220Vac)

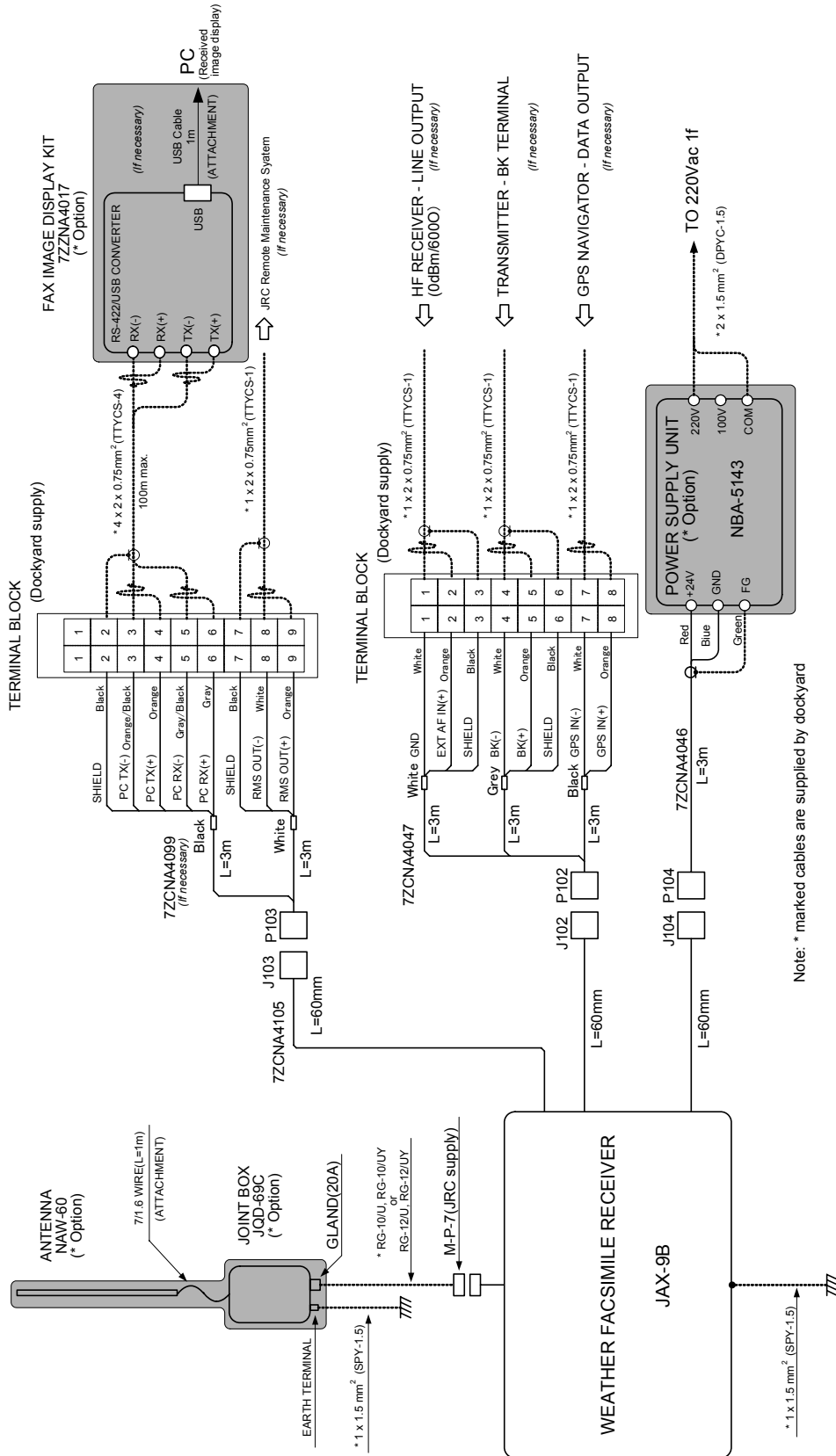

JAX-9B INTERCONNECTION DIAGRAM (220Vac)

Chapter 2 Names and Functions

2.1 Power Switch

The power switch is located on the back panel of JAX-9B.

The power switch has three modes of ON / OFF / TIMER (timer program recording).

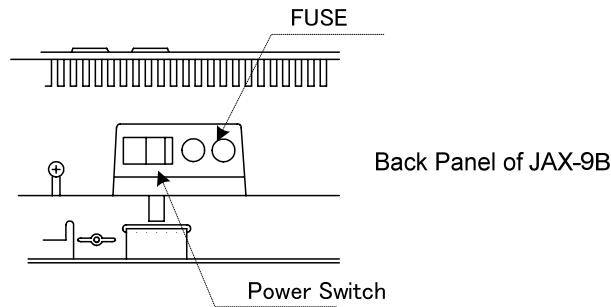

2.2 Operation Panel

See the following before reading the explanation of each operational switch.

1) Some switches have the function name with orange characters.

When a switch has the orange function name on it, it indicates that the switch has two functions. The function colored orange can be executed by combining with “#” switch. (Press a desired switch with orange function name after pressing the “#” switch.)

Hereinafter, the switch that can function alone is referred to as “single function.” The function that combines with the “#” switch is referred to as “combined function.”

* Only the combined functions used frequently are displayed in orange.

Some combined functions are not displayed in orange.

2) Beeps are heard when a button on the Operator panel is pressed.

A beep is heard when the button operation is properly accepted. Please note that three beeps are heard if the button operation is not accepted.

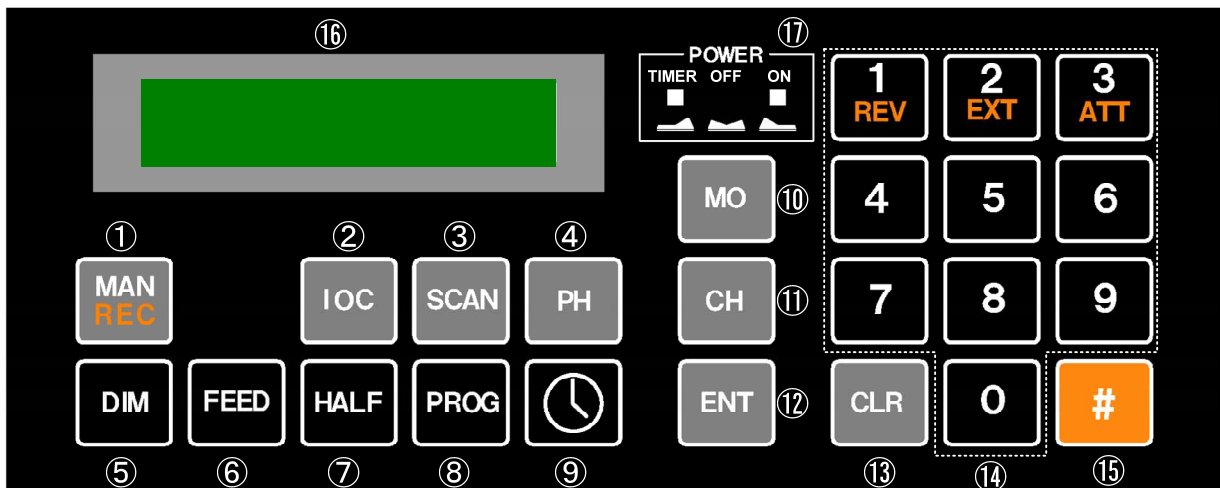

2.2.1 Operation of switches

No.	Name	Function	Note
①	MAN	<ul style="list-style-type: none"> • Single function Alternately switches between AUTO and MANU of recording mode. When the MANU mode is set, the IOC and the Scan speed must be set to those of the broadcasting station.	Not accepted; • during Forced recording
	REC	<ul style="list-style-type: none"> • Combined function (# → □) Starts the Forced recording. This recording mode is used when recording does not start in AUTO and MANU mode. To stop recording, press the [#] → [REC] again.	
②	IOC	Alternately switches between 288 and 576. Select the IOC according to a broadcasting station. An improper IOC will vertically enlarge or shrink recorded images.	Accepted; • MANU mode • during Forced recording
③	SCAN	Switches Scan speed in the order of 60, 90, 120, and 240 each time the switch is pressed. Select Scan speed according to a broadcasting station. With an improper Scan speed, JAX-9B cannot start recording. An improper Scan speed will record doubled-printing or overlapped-printing during Forced recording.	Accepted; • MANU mode • during Forced recording
④	PH	Adjusts a recording start position in horizontal direction.	Accepted; • during recording
⑤	DIM	<ul style="list-style-type: none"> • Single function Changes the intensity of illumination of the panel and LCD in the order of OFF, DARK, NORMAL, and BRIGHT each time this switch is pressed.	
		<ul style="list-style-type: none"> • Combined function (# → □) Changes the language on the LCD. Alternately switches between English and Japanese.	
⑥	FEED	Fast-feeds the facsimile paper and automatically stops it. To stop fast paper feeding, press this switch again.	Not accepted; • during Program entry
⑦	HALF	Activates for receiving cloud picture signals. To stop this half-tone printing function, press this button again. "H" character on the lower right of the LCD indicates under the half-tone printing.	
⑧	PROG	Starts an entry operation for timer program. To stop the entry operation, press this switch again.	Accepted; • AUTO mode

No.	Name	Function	Note
⑨		Shows the present time and set the correct time. To end the clock setting mode, press this switch.	Not accepted; • during Program entry
⑩	MO	Selects a channel for reading a registered frequency. Press a channel number after pressing MO, a registered frequency in the selecting channel is read.	Not accepted; • during Program entry • during Clock setting mode
⑪	CH	Selects a channel for registering or deleting a frequency.	Not accepted; • during Program entry • during Clock setting mode
⑫	ENT	Uses for registering a frequency, setting program and the correct time, and matching phases. Press this switch for entry of data.	Accepted; • during all registering-operation
⑬	CLR	<ul style="list-style-type: none"> • Clears a frequency displayed on the LCD. • Clears a registered frequency in channel memory, and registered program in timer program memory. • Stops a list printing. 	
⑭	TEN key	<ul style="list-style-type: none"> • Single function Uses for entering a frequency, time, channel number, and so forth.	
	1: REV	<ul style="list-style-type: none"> • Combined function (# → □) Reverses the black and white shades of the original image if the original image has white images on the black ground. To return to the normal printing, press the [#] → [REV] again. "R" character on the lower right of the LCD indicates under the reverse printing mode.	
	2: EXT	<ul style="list-style-type: none"> • Combined function (# → □) Enables an external receiver (other than the receiver in JAX-9B) to receive the facsimile broadcasting. To return to using the receiver in JAX-9B, press the [#] → [EXT] again. "E" character on the lower right of the LCD indicates under the external receiver mode.	
	3: ATT	<ul style="list-style-type: none"> • Combined function (# → □) Uses to attenuate external noises or disturbing noises from the other station (if any). An activity of ATT reduces about 20dB sensibility. Usually, keep it turned OFF. "A" character on the lower right of the LCD indicates under the activating ATT.	

No.	Name	Function	Note
⑭	4	<ul style="list-style-type: none"> • Combined function (# → □) Prints a list of frequency in a memory.	Accepted; • AUTO mode
	5	<ul style="list-style-type: none"> • Combined function (# → □) Prints a list of timer program in a memory.	Accepted; • AUTO mode
	6	<ul style="list-style-type: none"> • Fine-adjusting mode of frequency Uses to step up an indicated frequency in 100Hz under a fine-adjusting mode of frequency.	Accepted; • under a fine-adjusting mode
	7	<ul style="list-style-type: none"> • Combined function (# → □) Starts an adjusting mode of frequency. To stop an adjusting mode of frequency, press the [CLR] switch.	Accepted; • in recording • in waiting for recording
	8	No combined function (# → □)	
	9	<ul style="list-style-type: none"> • Fine-adjusting mode of frequency Uses to step down an indicated frequency in 100Hz under a fine-adjusting mode of frequency.	Accepted; • under a fine-adjusting mode
	0	<ul style="list-style-type: none"> • Combined function (# → □) Shows a software version on the LCD. The software version will clear after about five seconds automatically.	Accepted; • in waiting for recording
⑮	#	Executes a combined function. The combined function is activated by pressing a switch which has a combined function after pressing the "#" switch. "#" on the lower right of the LCD indicates accepting the "#" switch. To clear the "#", press this switch again. "#" disappears when 10 seconds pass while "#" is indicated, and the operation of the combined function is canceled.	

2.2.2 Display

No.	Name	Function
⑯	LCD	Displays time, frequency, recording mode, operating status of JAX-9B, entry data during the operation of each setting.
⑰	POWER LEDs	Shows power mode by two LEDs. (ON / TIMER) <ul style="list-style-type: none"> • Power ON : "ON" LED lights • Power OFF : Both LEDs light off • Timer mode : "TIMER" LED lights

2.3 Control Dials

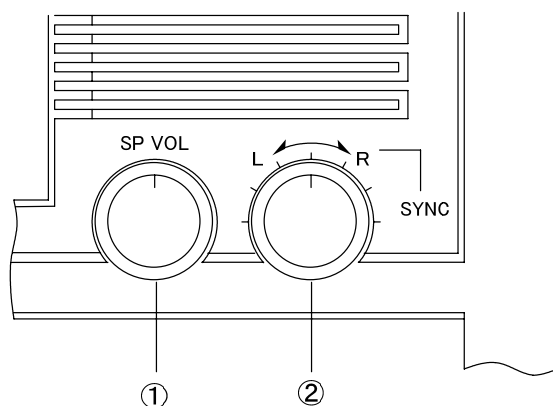

No.	Name	Function
①	SP VOL	Adjusts the monitor volume of the receiver.
②	SYNC	Adjusts recorded images to be straight, when it is printed out slantingly.

2.4 Button for Opening a Cover of Recording Paper

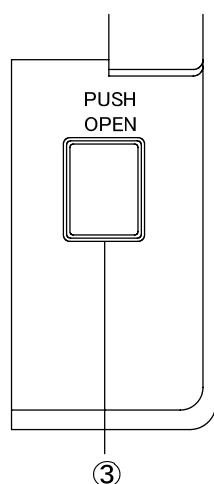

Right side of front panel

No.	Name	Function
③	PUSH OPEN	Press this button when replacing the facsimile recording paper. When this button is pressed, the thermal head moves away from the rubber roller platen and the top cover opens. Caution: Printing is disabled while the top cover is open. Close the top cover after replacing the facsimile recording paper. Otherwise, it causes a malfunction.

2.5 LCD Display

JAX-9B displays a recording mode and the operation status in the LCD. It is composed of the upper and lower row of 20 characters for each and 40 characters in total.

2.5.1 Startup

When power is turned on, JAX-9B starts up with the previous recording mode and frequency that was displayed just before powered off. It displays either of the figures below according to recording mode.

1) AUTO (Automatic recording mode)

W	a	i	t	i	n	g		s	t	a	r	t		s	i	g	n	a	l
f	=	2	2	7	7	0	.	0	/	1	2	#	()	

2) MANU (Manual recording mode)

①				②				③				④							
M	A	N	U	.	5	7	6	/	1	2	0								
f	=	2	2	7	7	0	.	0	/	1	2	#	()	
⑤												⑥		⑦	⑧	⑨	⑩	⑪	

2.5.2 During Recording

The LCD displays the following during recording the facsimile broadcasting.

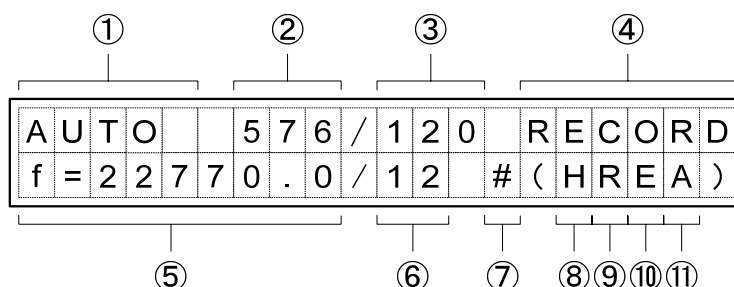

2.5.3 Display contents

No.	Name	Function
①	Recording mode	This field shows the current recording mode (AUTO, MANU, and #REC (Forced recording)). The above example shows the Automatic recording mode.
②	IOC	This field shows the scanning line density (Index of cooperation) (288 or 576). The above example shows 576.
③	Scan speed	This field shows the scan speed (60, 90, 120, or 240). The above example shows 120.
④	Operating status	This field shows the current operating status of JAX-9B (RECORD or PHASE or no display). The above example shows "Recording."
⑤	Receiving Frequency	This field shows the current receiving frequency (in kHz). The above example shows "22770.0 (kHz)."
⑥	Frequency channel	This field shows a frequency channel or group channel. The above example shows the frequency channel 12 on where 22770.0 kHz is registered.

Chapter 2 Names and Functions

No.	Name	Function
⑦	#	This field shows "#" when you press “#” switch and accepted. The combined function will be accepted by pressing next switch ([REC], [REV], [EXT], [ATT], [4], [5], [7], [0], [DIM]). The "#" is cleared by activating a combined function. To clear the "#" while displaying "#", press this switch again.
⑧	Half-tone printing	This field shows whether the Halftone Recording function is used. The above example (“H”) shows that the Halftone Recording function is used.
⑨	Reverse printing	This field shows whether the black and white of the original image is reversed. The above example (“R”) shows that the image is reversed (to have the black ground).
⑩	External receiver	This field shows whether external receiver mode is on. The above example (“E”) shows external receiver mode is on.
⑪	ATT	This field shows whether the attenuator is turned on or off. The above example (“A”) shows the attenuator is turned on.

Chapter 3 Installation

Please request JRC service engineer for the installation and wiring work for JAX-9B Weather Facsimile Receiver on purchase.

WARNING



Do not use any power supply voltage other than the specified one.
Such an action may cause a fire, an electric shock, or equipment malfunction.



Do not insert or drop any foreign objects such as removed screws and metallic pieces into an air vent or opening while working. Otherwise, it may cause a fire, electric shock or malfunction.

CAUTION



Do not conduct operations with wet hands.
Otherwise, it may cause an electric shock.



Do not connect the power cable to the common power outlet with any other cables with high power noise (such as for an air conditioner).
Otherwise, it may cause a receiving interference.



Do not install the equipment on the unstable place such as on the shaky stand or inclined surface. Otherwise, it may drop or fall down, resulting in an injury or malfunction.



Connect the earth line to the earth terminal firmly.
Otherwise, it may cause an electric shock when the equipment has a failure or electric leak.

3.1 Installation Procedure

- 1) Press the [PUSH OPEN] button. The top cover opens.
- 2) While pressing the bottom of the front cover against the facsimile body, pull the top of the front cover toward you to open.
- 3) Remove the recording paper roll.

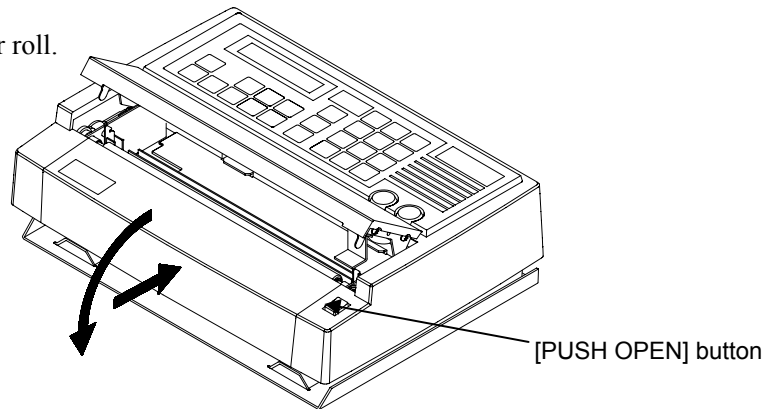

- 4) Remove two screws on the bottom of the paper holder.

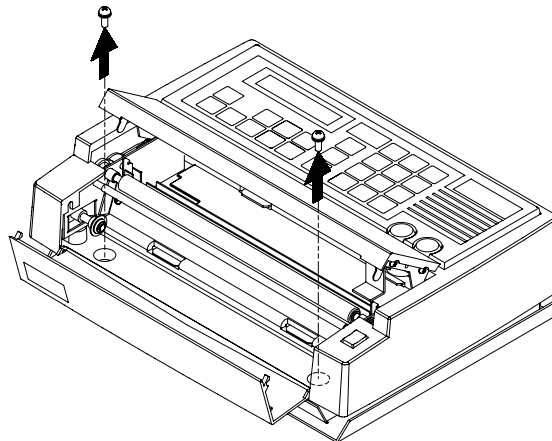

- 5) Pull the facsimile body toward you (in the arrow direction) until the facsimile body comes off the mounting base.

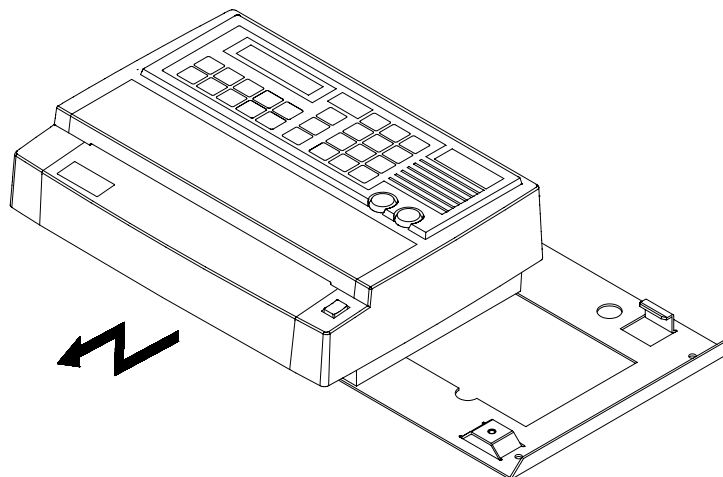

- 6) Mount the mounting base with four M5 bolts or four wood screws.

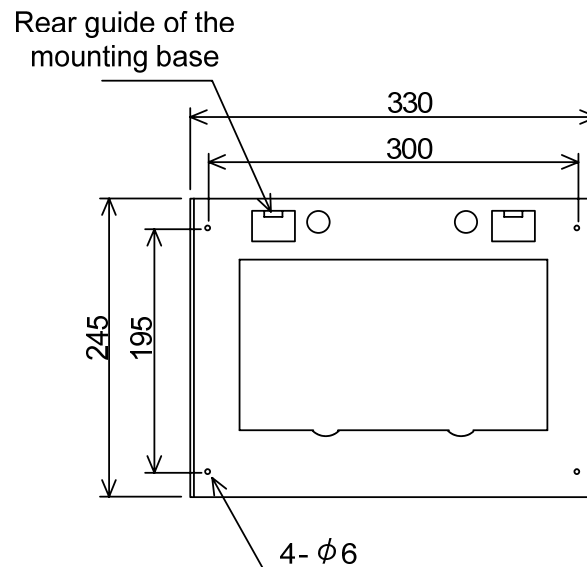

- 7) Reverse the above steps to remount the facsimile body and set the recording paper roll in it.

- 8) Connect the antenna cable, the power cable, and the earth.

Connect the BK input cable, AF input cable of the external receiver, and the GPS data input cable if needed.

Refer to 3.7 for wiring details.

NOTE

- The AF signal of external receiver and the BK signal have a polarity. Be careful in connecting them to JAX-9B.
- If a transceiver is installed, connect the BK signal cable from the transceiver to JAX-9B.

MEMO

- "BK" is an abbreviation of "BREAK", which means the disconnection of the antenna from JAX-9B. If JAX-9B is installed with a radio transmitting equipment such as a HF transceiver, the BK signal sent from the transceiver disconnects the antenna from JAX-9B and protects the internal receiver against the transmitting radio waves from the transceiver.

3.2 Precautions for Installation

1) Supply voltage

JAX-9B operates within the following voltage range shown below.

- DC power supply: +10Vdc to +42Vdc
(Standard voltage: +12Vdc, +24Vdc, +32Vdc -10% to +30%)
- AC power supply: Option (Rectifier unit NBA-5143 is required.)

NOTE

- When not using AC power supply (option), connect cables after confirming the voltage between FG and the minus terminal of DC power supply is 0V.

2) Selection of FUSE

The capacity of a fuse available to JAX-9B varies depending on the supply voltage. JAX-9B is equipped with 5A fuse at the factory. Select a proper fuse (among replacement fuses) according to the supply voltage and set it in the fuse holder.

The fuse holders are next to the power switch on the rear of JAX-9B.

- +12Vdc power supply: Use an 8A fuse.
- +24Vdc power supply: Use a 5A fuse.
- +32Vdc power supply: Use a 5A fuse.

3) When using existing equipment

When connecting existing equipment that has already been in use inboard such as antennas and external receivers, etc., connect them to JAX-9B after confirming the result of single-equipment operation is normal. (Whether or not it is damaged and it starts up with power supply, and insulation check, etc.)

3.3 Changing Display Language

Basically JAX-9B uses alphanumeric characters for labels and data on the LCD. Japanese characters are also available to JAX-9B. To use Japanese characters, take the following steps:

1) Changing display language on switches

Stick attached Japanese labels on each corresponding switch.

For the locations of each label, see the following figure.

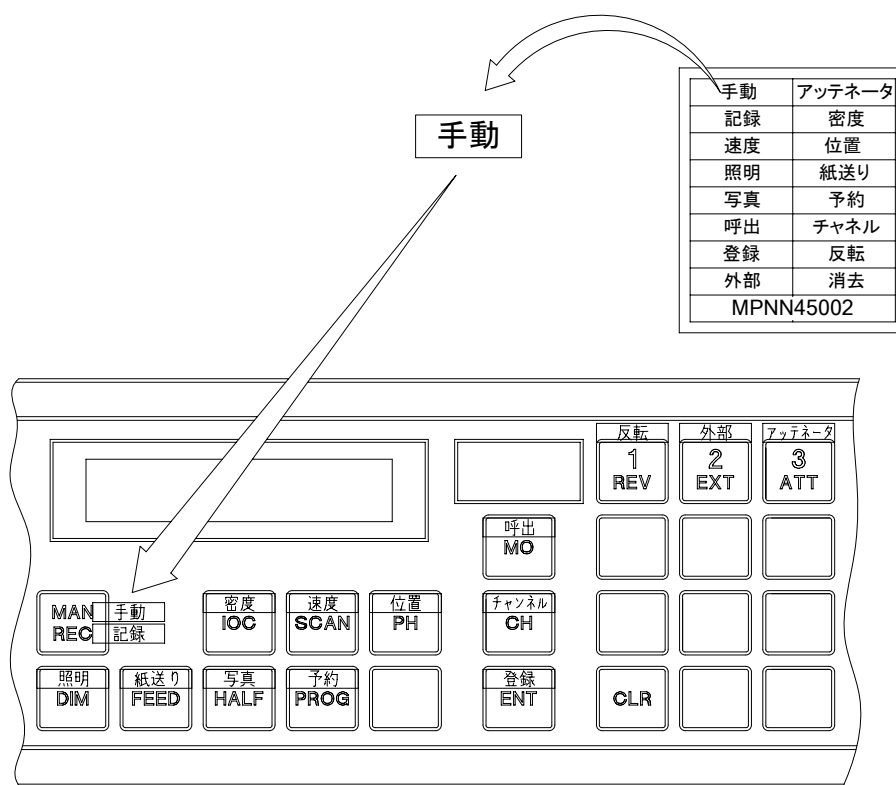

2) Changing display language on the LCD

Press the [#] + [DIM] switch, turn off power and then turn it back on again.

The display language (Japanese/English) changes after the operation mentioned above.

3.4 Connection of GPS Receiver

The internal clock of JAX-9B can be automatically updated by time data received from the GPS receiver. However, because of the necessity for registering the time difference with the standard time (UTC) that the GPS receiver outputs, it is necessary to set the time of the internal clock manually only once after connecting to the GPS receiver.

For the details of connecting the GPS receiver, refer to Chapter 6.

3.5 Remote Maintenance Function

The state of JAX-9B can be monitored from the remote place by connecting JAX-9B with our VDR for remote maintenance.

Request the connection with VDR to our service person.

3.6 Optional Function

JAX-9B supports the new function that transmits the received images to a personal computer.

The received (recorded) image is displayed on the PC by this optional function.

In order to add this option, it is necessary to connect the cable from PC to the optional terminal board of JAX-9B.

For the details of the optional function, refer to Chapter 7.

3.7 Installation Drawing

JAX-9B can be mounted on the wall or on the desktop. Secure space as shown in the figure below around JAX-9B for maintenance, and set it up within the range of the LCD viewing angle.

Left and right space of the facsimile on the desktop

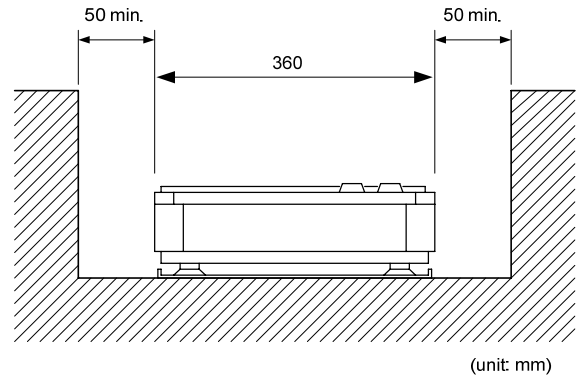

Upper and rear side space of the facsimile on the desktop

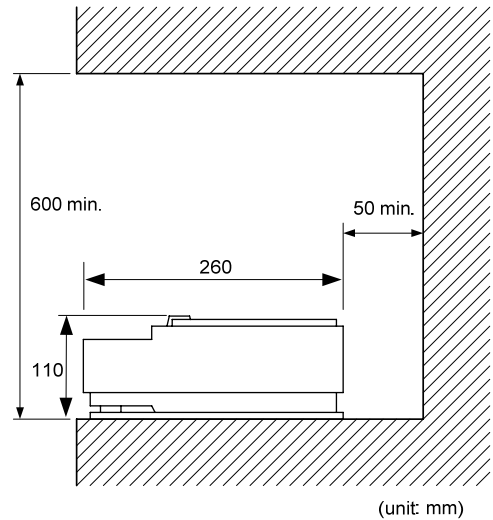

Upper and lower space of the facsimile on the wall and LCD viewing angle

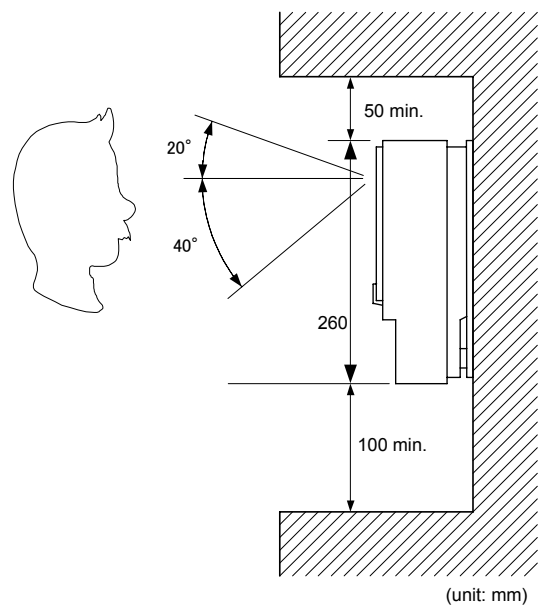

3.8 Connection of Cables

3.8.1 Wiring of Standard Configurations

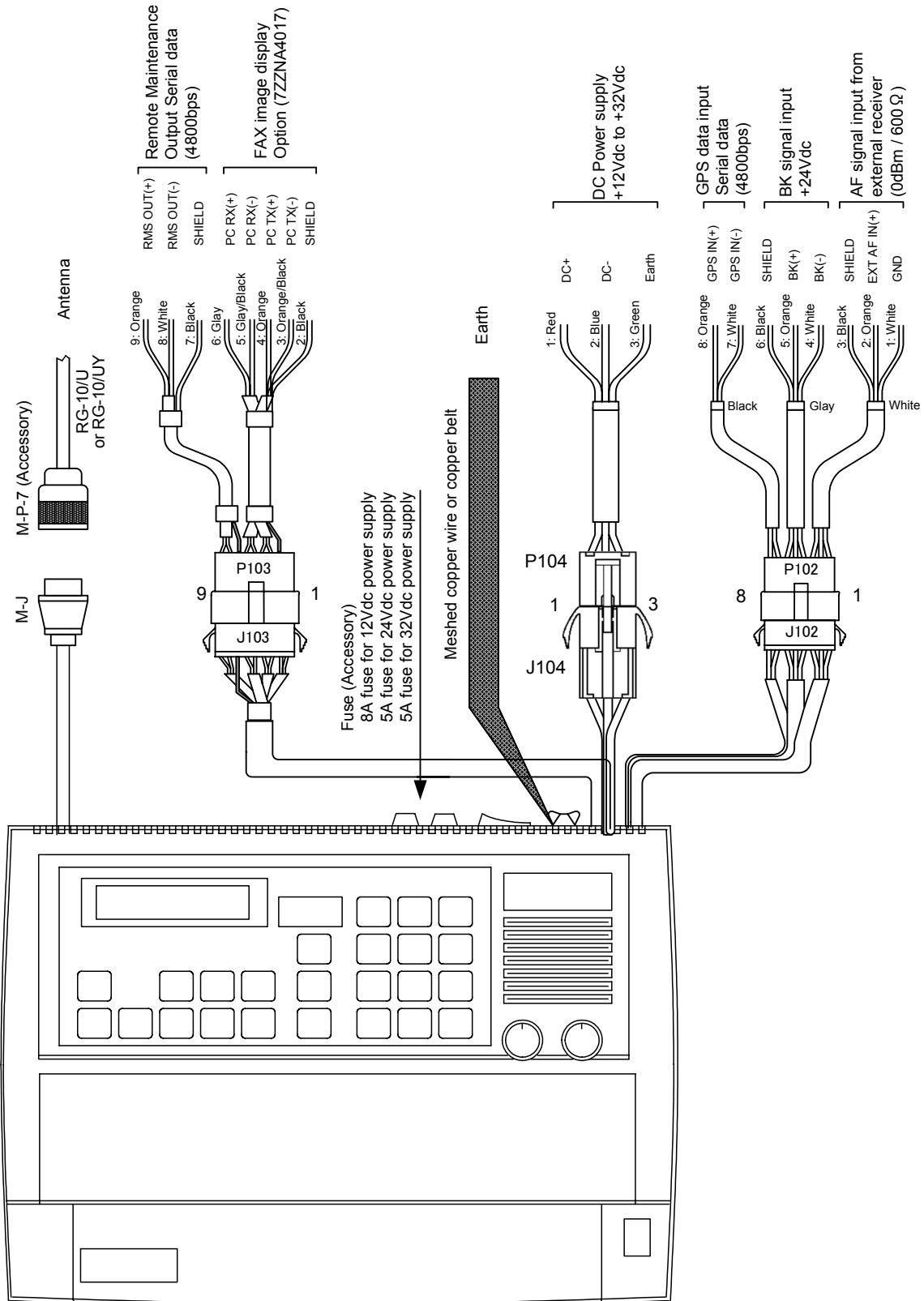

3.8.2 Power Supply Wiring When Connecting to AC Power Supply (Option)

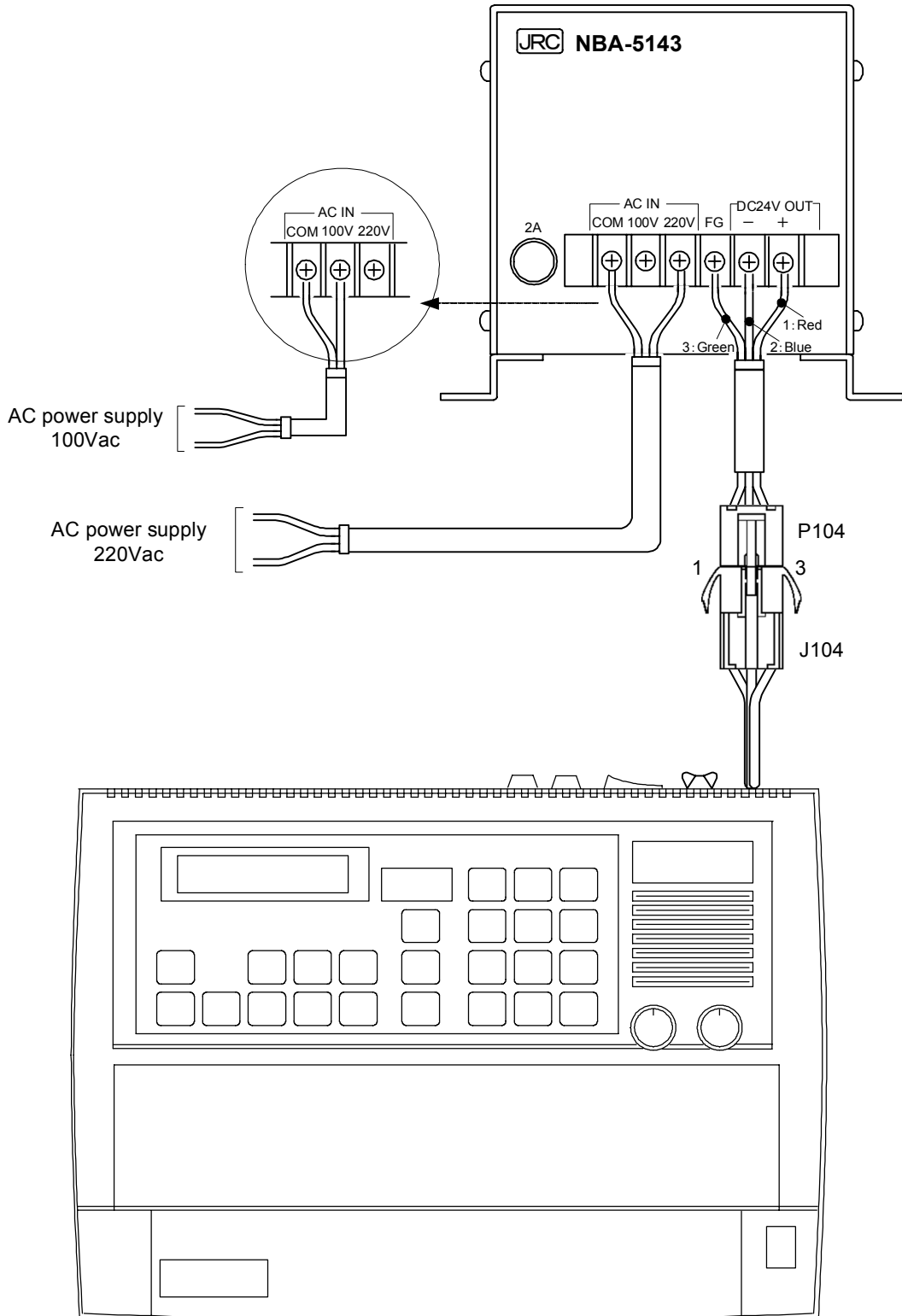

3.8.3 Connecting to Personal Computer (Option)

The installation method is described on the “*Instruction Manual for the Viewer Software*” in the separate volume.

Chapter 4 Operation

This Chapter describes the operation procedure for receiving facsimile broadcasting in the following Sections:

● Selection and Setting of Receiving Frequency (Automatic Frequency Selection)	4.1
● Recording Modes	4.2
● Reception of Facsimile Broadcasting	4.3
● Registration of Frequency Channel	4.4
● Timer Program Recording (Registration)	4.5
● Additional Functions in accordance with Broadcasting and Reception ...	4.6
● Necessary Functions for Operating of Facsimile	4.7
● Alarm Indications	4.8

4.1 Selection and Setting of Receiving Frequency (Automatic Frequency Selection)

A facsimile broadcasting station broadcasts the same program on multiple frequencies at the same time. When a facsimile broadcasting is received, the received image quality depends upon the propagation conditions of the selected received frequency. The propagation conditions of the broadcasting frequencies are different in season, daytime and nighttime, and place of receiving. Since the best received frequency is not absolutely fixed, it is necessary to select the best received frequency to record the good quality image whenever it is received.

JAX-9B Facsimile Equipment incorporates the functions of automatically selecting and setting the best received frequency of the specified frequencies (automatic frequency selection).

4.1.1 Setting Receiving Frequency

The receiving frequency can be preset in the following two methods:

- a) Method of setting a receiving frequency by ten-key entry.
- b) Method of recalling a frequency channel (00 - 99) and setting the best frequency.

1) Setting of Receiving Frequency by Ten-key Entry

Enter a desired receiving frequency digit by digit using ten-key switch.
JAX-9B starts receiving a facsimile image on the indicated frequency.

2) Recalling and Setting Frequency Channel (00 – 99)

Enter a frequency channel (00 – 99) on which a desired receiving frequency is registered.
JAX-9B starts receiving a facsimile image when the registered frequency is read out.

- (Single) frequency channel

The receiving is started on a single registered frequency.
A maximum of 90 frequencies can be registered in a single channel.
* For the available channel numbers, refer to Table 4.1.

- Group channel

The automatic frequency selection function can be performed on multiple frequencies registered in a group channel and start receiving a selected frequency that is determined as good.
A maximum of 10 group channels are available.
* For the available channel numbers, refer to Table 4.1.

NOTE You cannot register any frequencies in group channels.

Table 4.1 Registered frequency channels

Group Channel	Frequency Channel	Automatic Frequency Selection Function
00	01 to 09	When selecting a group channel, the automatic frequency selecting function is performed in using the frequencies (up to 9 frequencies) in the right column of frequency channel.
10	11 to 19	
20	21 to 29	
30	31 to 39	
40	41 to 49	
50	51 to 59	
60	61 to 69	
70	71 to 79	
80	81 to 89	
90	91 to 99	
Total 10 groups	Total 90 frequencies	

4.1.2 Automatic Frequency Selection Function

This JAX-9B is designed to automatically select a frequency in the good receiving condition from all frequencies that are broadcasted from the same broadcasting station.

If the receiving condition of a selected frequency becomes worse gradually, the equipment will automatically select another frequency in the good receiving condition.

For using this function, it is required to register more than one frequency which broadcasts a fax broadcasting of the identical contents simultaneously in the frequency channels of a same group.

1) Setting Procedure

Register all frequencies of a broadcasting station that you desire to record in the frequency channels of a same group. For example, when choosing the fax broadcasting of JMH automatically, the receiving frequencies are registered as follows.

(When registering in the group channel 00)

- Register 3622.5 kHz in the frequency channel 01.
- Register 7795.0 kHz in the frequency channel 02.
- Register 13988.5 kHz in the frequency channel 03.
- Do not register any frequencies in other frequency channels (04 to 09).

MEMO JMH is the name of the facsimile broadcasting station under the control of Meteorological Agency of Japan.

The frequencies shown above are the JMH broadcasting frequencies as of March 2008.

NOTE The FAX broadcasting from a desired broadcasting station cannot be received if the frequencies of another broadcasting station are registered in the same group channel. Do not register different broadcasting stations in the same group channel.

2) Cautions for Using Automatic Frequency Selection Function

- This function works when operating the internal receiver of this equipment. Thus, the function cannot be used in operating an external receiver.
- Perform this function about one minute before the start of broadcast because a certain time is required for the comparison of the receiving conditions of all the frequencies registered in a same group and selection of the best frequency.
- The receiving condition of an automatically-selected frequency is not absolutely good for the following reasons:
 - a) When the condition of frequencies to be selected is generally in the adverse propagation.
 - b) When the propagation condition is good only while the frequencies are compared.
 - c) When the propagation condition of an automatically-selected frequency is gradually becoming worse.
- This function is available in all 4 receiving modes (automatic recording, manual recording, forced recording and timer program recording).

4.2 Recording Modes

A facsimile broadcasting can be received in the following 3 options:

- a) Detecting a facsimile broadcasting signal to start recording automatically.
 - Automatic recording mode
 - Manual recording mode
- b) Starting recording only at specified time
 - Program recording mode
- c) Starting the recording by force in manual operation.
 - Forced recording

MEMO Select a recording mode depending upon the facsimile broadcasting receiving condition.

- Automatic Recording: Start the recording in the automatic recording mode in the good receiving condition.
- ↓
- Manual Recording: When the recording cannot start, it may start by changing to manual recording mode.
- ↓
- Forced Recording: Start the recording in forced recording mode if the recording cannot be started in the manual recording mode.
In this case, however, the recorded image may contain much noise.

- 1) Detecting a facsimile broadcasting signal to start recording automatically.

JAX-9B detects the facsimile broadcasting signal and starts recording automatically in receiving standby mode. For the receiving standby mode, it is necessary to select the “Automatic Recording Mode” or the “Manual Recording Mode”.

● Automatic Recording Mode

In this mode, JAX-9B automatically detects the control signal contained in the facsimile broadcasting signal, matches the receiving parameters and starts recording automatically.

- * JAX-9B will record all the programs that are being broadcasted on the preset receiving frequencies.
- * JAX-9B on the automatic receiving mode requires receiving a FAX program from the beginning of the broadcast.
JAX-9B cannot receive (record) a FAX program from the middle of the broadcast.

- Manual Recording Mode

Preset the receiving parameters. Recording will be started only when JAX-9B receives the broadcast matched with the preset parameters.

* Parameters: Density (IOC) = 576 / 288
 Speed (Scan speed) = 60 / 90 / 120 / 240

* JAX-9B can receive (record) a FAX program from the middle of broadcast.

2) Starting the recording only at specified time

In the "Program Recording Mode," JAX-9B only records the facsimile broadcasting at specified time.

It is necessary to confirm the facsimile broadcasting schedule and register the starting time and the finishing time according to the program that you desire to record.

- Program Recording Mode

When power supply switch is set to the TIMER mode, the power supply becomes a standby power supply (only the TIMER lamp lights) and enters the state of turning on only during specified time, and the facsimile broadcasting is received (recorded).

3) Starting recording by force in manual operation

The recording is started coercively by starting operation of manual recording.

- Forced Recording

Recording is started in accordance with the preset receiving parameters. Normal images cannot be recorded if the preset parameters do not match with the broadcasting parameters. Therefore, it is necessary to preset proper receiving parameters in manual operation and synchronize the phase manually.

* This mode should be used when the receiving condition is so bad that the recording cannot be started in the automatic/manual recording mode.

4) Facsimile Broadcasting Signal

It explains control signals included in the facsimile broadcasting signal. JAX-9B can determine the starting and finishing point of recording and receiving parameters by detecting these control signals.

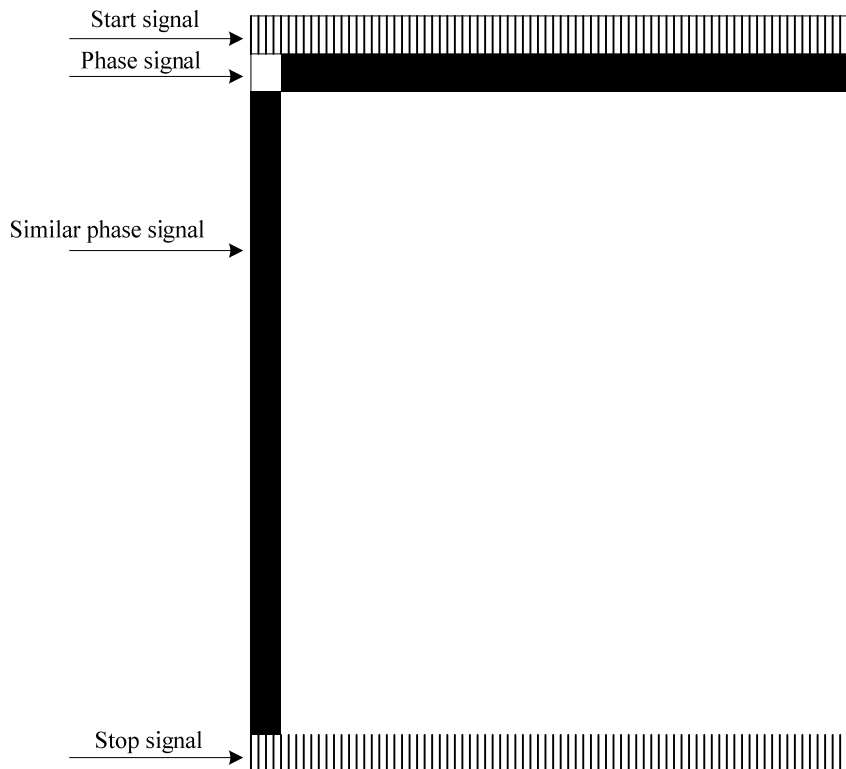

- Automatic Recording Mode: JAX-9B detects the start signal and the phase signal, then start recording.
- Manual Recording Mode: JAX-9B detects the phase signal or similar phase signal, then start recording.
- Receiving parameters: The IOC (density) (288 / 576) is detected from the start signal.
The scan speed (60 / 90 / 120 / 240) can be detected from the phase signal.

4.3 Reception of Facsimile Broadcasting

The procedure necessary to receive a facsimile broadcasting is the following three steps.

- 1) **Turning on the Power** Refer to 4.3.1
- 2) **Setting Receiving Frequencies** Refer to 4.3.2
- 3) **Selecting Recording Mode** Refer to 4.3.3

* The timer program recording is described in Section 4.5.

4.3.1 Turning on the Power

- 1) Method of turning on the power

Push down the main power switch to the right on the rear side of JAX-9B.

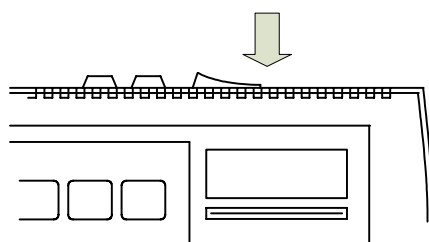

- 2) Panel Indicator

- The POWER indicator lamp lights up.
- The setting condition and the operation condition are displayed on the LCD.

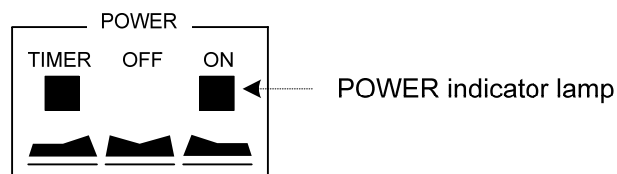

4.3.2 Setting Receiving Frequencies

Input a receiving frequency in any of the following methods:

- **Direct Input of a Receiving Frequency Using Ten-key Switch** ····· a)
- **Setting a Receiving Frequency by Frequency Channel** ········· b)
- **Setting a Receiving Frequency by Group Channel** ··········· c)

4.3.3 Setting Recording Mode



Select any of the following recording modes:

- **Setting Automatic Recording Mode** a)
- **Setting Manual Recording Mode** b)
- **Starting Forced Recording** c)

a) Setting Automatic Recording Mode

Operation Procedure

- 1)  : Set the recording mode to “AUTO”.
 (The Automatic and the Manual recording modes are alternately switched over.)



No.	Switch	Indication	Description
1		Manual recording mode M A N U 5 7 6 / 1 2 0  Automatic recording mode W a i t i n g s t a r t s i g n a l	<ul style="list-style-type: none"> Select the recording mode. If the mode is set to “MANU”, switch it to the “AUTO”.
2		W a i t i n g s t a r t s i g n a l	<ul style="list-style-type: none"> Waiting for Start signal. The indication blinks until the facsimile broadcasting starts.
3		A U T O 5 7 6 / S c a n	<ul style="list-style-type: none"> Receiving of Start signal. The broadcasting IOC is detected from the Start signal and indicated.
4		A U T O 5 7 6 / S c a n	<ul style="list-style-type: none"> Receiving of Phase signal. The indication of “Scan” blinks.
5		A U T O 5 7 6 / 1 2 0 P h a s e	<ul style="list-style-type: none"> Phase matching. The broadcasting scan speed is detected from the phase signal and indicated. The indication of “Phase” blinks.
6		A U T O 5 7 6 / 1 2 0 R E C O R D	<ul style="list-style-type: none"> Start recording. When the phase matching is finished, recording starts.
7		W a i t i n g s t a r t s i g n a l	<ul style="list-style-type: none"> Receiving Stop signal. The recording paper is fed and stops at the cut position. JAX-9B returns to the waiting status for the reception of the next broadcast.





- 2)  x 2 : Recording stops when [MAN] switch is pressed twice during recording. Pressing it once only switches to manual recording mode and the recording continues if the receiving parameters are matched with the broadcasting parameters (IOC and Scan speed).

b) Setting Manual Recording Mode

Switch to manual recording mode if the recording cannot start in automatic recording mode.

Operation Procedure

- 1)  : Set the recording mode to “MANU”.
(The Automatic and the Manual recording modes are alternately switched over.)
- 2)   : Select IOC (density) and Scan speed.

No.	Switch	Indication	Description
1		Automatic recording mode W a i t i n g s t a r t s i g n a l  Manual recording mode M A N U 5 7 6 / 1 2 0 P h a s e	<ul style="list-style-type: none"> Select the recording mode. If the mode is set to “AUTO”, switch it to the “MANU”.
2		M A N U 5 7 6 / 6 0 P h a s e	<ul style="list-style-type: none"> Select IOC (density). Whenever the switch is pressed, the IOC of 288/576 are switched over.
3		M A N U 5 7 6 / 1 2 0 P h a s e	<ul style="list-style-type: none"> Select Scan Speed. Whenever the switch is pressed, the Scan speed is switched over in order of 60/90/120/240.
4		M A N U 5 7 6 / 1 2 0 R E C O R D	<ul style="list-style-type: none"> Start recording. Recording starts by receiving the phase or image signal.
5		M A N U 5 7 6 / 1 2 0 P h a s e	<ul style="list-style-type: none"> Receiving Stop signal. JAX-9B returns to the waiting status for the reception of the next broadcast.

- 3)  x 1 : Recording stops by pressing [MAN] switch once during recording.











NOTE







- In the manual recording mode, recording can start by detecting the similar phase signal in image signals. If the similar phase signal is not contained in the image signals (broadcast), it is impossible to start recording in the middle of image broadcasting.
- Setting of wrong IOC (density) makes the recorded image vertically expanded or contracted.
- Recording will not start when the wrong Scan speed is set.
- If Scan speed is changed during recording, JAX-9B will enter the status of waiting for phase and stop recording.



c) Starting Forced Recording

Start the recording in forced recording mode if the recording cannot be started in the manual recording mode.

Operation Procedure

- 1)  : Set the recording mode to “MANU”.
(The Automatic and the Manual recording modes are alternately switched over.)
- 2)   : Select IOC (density) and Scan speed. (in manual recording)
- 3)  +  : Start forced recording.
- 4)  : Adjust the phase (position where the image is recorded).
 - 
- 5)  : Confirm the adjusting value of the phase.
- 6)  +  : Stop forced recording.

No.	Switch	Indication	Description
1		MANU 5 7 6 / 1 2 0 # ()	<ul style="list-style-type: none"> • Combined function mode. “#” is indicated. Pressing [#] switch once more, the mode is released.
2		# REC 5 7 6 / 1 2 0 ()	<ul style="list-style-type: none"> • Forced recording starts.
3		# REC 5 7 6 / 1 2 0 PH = ()	<ul style="list-style-type: none"> • Check the phase (recording position) and if necessary, start the phase adjusting mode.
4	 	# REC 5 7 6 / 1 2 0 PH = 2 3 ()	<ul style="list-style-type: none"> • Input the adjusted position. Enter a scale value (1 ~ 31) corresponding to the position at which the phase signal (similar phase signal) is recorded.
5		# REC 5 7 6 / 1 2 0 ()	<ul style="list-style-type: none"> • Confirm the adjusted position. The recording position moves parallel in correspondence with the entered adjusting value.

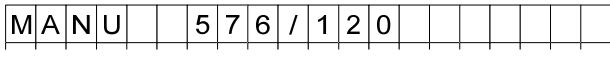
No.	Switch	Indication	Description
6	 + 		<ul style="list-style-type: none"> • Stop recording. Even if the image receiving stops, recording does not stop automatically. Stop recording by manual stop operation.

● Phase adjustment mode

- A state that no phase matching is made though recording started
 - Check the scale value at which the phase position (similar phase signal) is recorded. The scale value is “23” in the figure below.

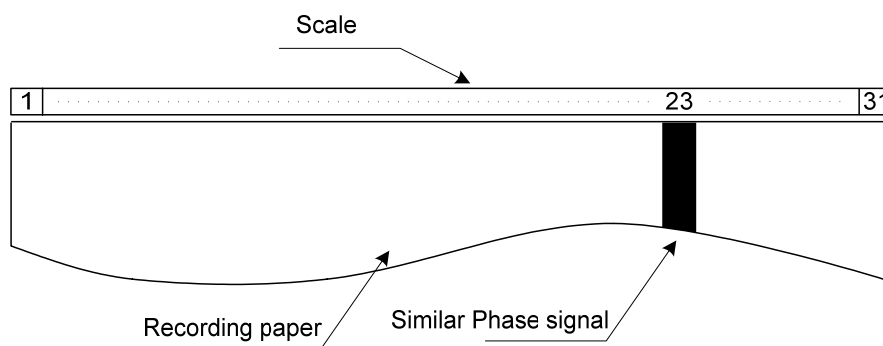

- Execute the phase adjustment operation.
- A state that the phase adjustment is completed.
 - When the phase adjustment is completed, the similar phase signal is divided and appears at both ends, or it is indicated either the left or right end.

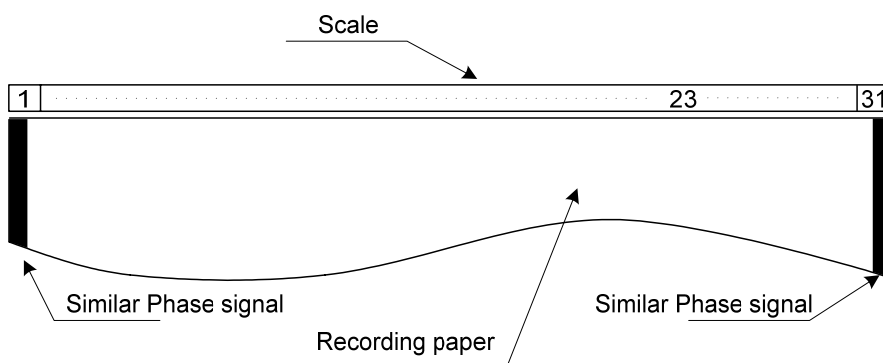

NOTE

- Some broadcasting stations do not send the similar phase signal. In that case, make the phase adjustment assuming a break of the image as the similar phase signal.

4.4 Registration of Frequency Channel

JAX-9B is capable of registering a total of 90 receiving frequencies in 10 groups of 9 frequencies in the memory.

Table of frequency channel registration









Group Channel	Frequency Channel	Automatic Frequency Selection Function
00	01 to 09	When a group channel is selected for reception, the automatic frequency selection function is performed in using the frequencies (up to 9 frequencies) in the right column of group channel numbers.
10	11 to 19	
20	21 to 29	
30	31 to 39	
40	41 to 49	
50	51 to 59	
60	61 to 69	
70	71 to 79	
80	81 to 89	
90	91 to 99	
Total 10 groups	Total 90 frequencies	

The operations related to the registration of frequency channels are described in the following Sections.







- 1) **Registering Frequency Channels** Refer to 4.4.1
- 2) **Deleting Registered Frequencies** Refer to 4.4.2
- 3) **Printing List of Registered Frequencies** Refer to 4.4.3

4.4.1 Registering Frequency Channels

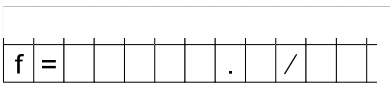
Operation Procedure

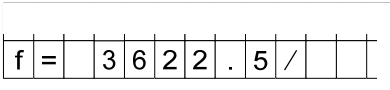
- 1)  : Clear the indication of a receiving frequency.
- 2)  -  : Enter a receiving frequency.
- 3)  : Set the frequency channel registration mode.
- 4)  -  : Assign a registration channel.
- 5)  : Enter and register an entered frequency in the assigned channel.
- 6)  or  : Set the receiving frequency, and return to the standby mode.

NOTE • Executing the operation of setting the receiving frequency (reading-out the frequency channel / manual setting of the frequency) can end the operation of frequency channel registration.

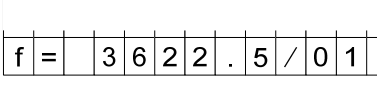
No.	Switch	Indication	Description
1			Clear the frequency indication.
2	 	Frequency: 3622.5kHz Enter [3], [6], [2], [2], [5] in turns. 	Enter a frequency.
3			Set the channel number entry mode.
4	 	Frequency channel: CH01 Enter [0], [1] in turns. 	Enter the registration channel number.







- Execute the operation for registration of all the channels up to the last channel (CH*9) in the same group in order to use the automatic frequency selection function. If it is unnecessary to enter any frequencies, only press [ENT] switch so that the registered frequencies will be cleared.

Example: In receiving the broadcasting station that broadcasts with six frequencies by the automatic frequency selection function, it is necessary to register receiving frequencies as follows;

- Register receiving frequencies from *1 CH to *6 CH.
- Clear registered frequencies from *7 CH to *9 CH.

4.4.2 Deleting Registered Frequencies

Operation Procedure

- 1)  : Clear the received frequency indication.
- 2)  : Set the frequency channel readout mode.
- 3)  -  : Specify any channels to be cleared.
- 4)  : Push [ENT] switch when no frequency is indicated, and the registration on any specified channels will be cleared.
- 5)  or  : Set the receiving frequency, and return to the standby mode.



- NOTE** • Executing the operation of setting the receiving frequency (reading-out the frequency channel / manual setting of the frequency) can end the operation for clearing the frequency channels.

4.4.3 Printing List of Registered Frequency

The registered frequency channels can be printed out as a list in recording paper.

After the registration of frequency channels, check if no setting error was made by the printed list of registered frequency channels.

Operation Procedure

- 1)  : Set the combined function mode.
- 2)  : Start printing the list of registered frequency channels.
- 3)  : Press [CLR] switch to end the printing of the list.

After the printing of the list is completed, JAX-9B returns to the standby mode automatically.

→ It is unnecessary to execute the ending operation.

- NOTE** • The list of registered frequency channels can be printed out on the automatic recording mode of main power operating only. In the case of the manual recording mode, change the recording mode to the automatic recording mode.

JAX-9B FREQUENCY LIST

(CH)	FREQ.	(CH)	FREQ.	(CH)	FREQ.	(CH)	FREQ.	(CH)	FREQ.
(00)	GROUP.	(01)	3622.5	(02)	7795.0	(03)	13988.5	(04)	
(05)		(06)		(07)		(08)		(09)	
(10)	GROUP.	(11)		(12)		(13)		(14)	
(15)		(16)		(17)		(18)		(19)	

•
•
•
•
•

4.5 Timer Program Recording (Registration)

By registering the timer program, JAX-9B is able to receive (record) 15 facsimile broadcasting in 24 hours.

The operation procedure necessary for timer program recording is executed in the following three steps.

- 1) **Registration Timer Program** Refer to 4.5.1
- 2) **Setting Internal Clock** Refer to 4.7.1
- 3) **Setting Power Switch to Timer Mode** Refer to 4.5.2

Then, the editing operation of the registered programs is executed as shown below.

- 4) **Verifying Timer Program** Refer to 4.5.3
- 5) **Modifying Timer Program** Refer to 4.5.4
- 6) **Deleting Timer Program** Refer to 4.5.5
- 7) **Printing List of Timer Programs** Refer to 4.5.6

4.5.1 Registration Timer Program

Register the program for timer program recording.

Operation Procedure

The timer programs can be registered at the automatic recording mode only.

Switch the recording mode to the automatic recording mode before starting registration procedure, if it is set to the manual recording mode.

- | | | |
|-----|---------------------|---|
| 1) | PROG | : Start the timer program registration. |
| 2) | 0 - 9 | : Enter the Program Number.
Program Number: 1 to15, Total 15 channels. |
| 3) | ENT | : Confirm the program Number. |
| 4) | 0 - 9 | : Enter the receiving starting time.
Enter 4 digits of hours and minutes: [H] [H] [M] [M] |
| 5) | ENT | : Confirm the starting time. |
| 6) | 0 - 9 | : Enter the receiving finishing time.
Enter 4 digits of hours and minutes: [H] [H] [M] [M] |
| 7) | ENT | : Confirm the finishing time. |
| 8) | 0 - 9 | : Enter the receiving frequency channel / group channel (2-digit). |
| 9) | ENT | : Confirm the frequency channel. |
| 10) | MAN
REC | : Select the recording mode. * The operation of 12) - 15) is not required for the automatic recording mode. |
| 11) | ENT | : Confirm the recording mode. |
| 12) | IOC | : Select the IOC if the manual recording mode is selected. |
| 13) | ENT | : Confirm the IOC. |
| 14) | SCAN | : Select the Scan speed if the manual recording mode is selected. |
| 15) | ENT | : Confirm the Scan speed. |

- 16) **HALF** : Select the half-tone recording mode (valid / invalid).
No indication means Invalid.
- 17) **ENT** : Confirm the half-tone mode.
For continuous registration of the next program, return to step 2).
- 18) **PROG** : Complete the timer program registration.

● LCD indications of each registering item

The item to be entered is indicated by “_” (underline).

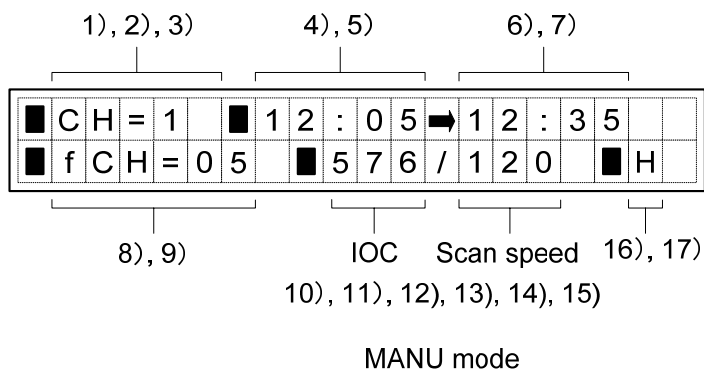
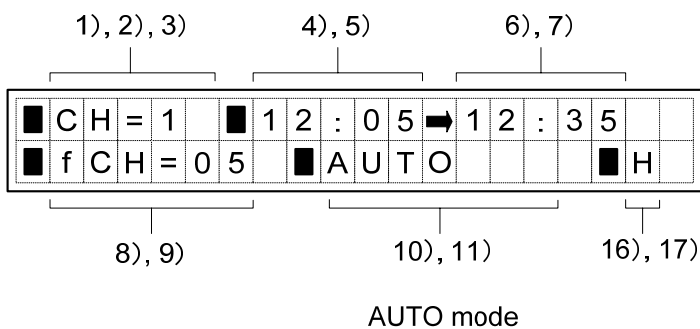

NOTE

- Timer programs cannot be registered while operating in timer program recording mode
- The program numbers in which the program can be registered are 15 programs of 1-15.
- Set the time on the 24-hour basis.
The entry time is acceptable in either UTC or LMT. The program, however, operates according to the time of internal clock; therefore, if you register by referring to the broadcasting program guide where standard time differs, be careful for the registration time.
- When inputted an erroneous parameter in the middle of setting, press the [CLR] switch and re-enter the right parameter.
- Enter and confirm all items. (The last item is half-tone registration.) If the entry of all items is not completed, registration is canceled.
- Registration can be stopped if the [PROG] switch is pushed in the middle of the registering operation of the timer program.
- Set the starting time about one minute before the starting time of the broadcast.
- Do not register timer programs that conflict each other in the same receiving time zone. The first started program is preferential and the other programs which have the same time zone are canceled. Print the list of registered programs to verify the programs. → Refer to 4.5.6.
Examples of wrong setting: Program 1: 10:00 ~ 10:30
Program 2: 10:15 ~ 10:45
- If the time in the internal clock is wrong, the timer program recording will fail.
Correct the preset time before operating timer program recording.
(The time can be corrected automatically by connecting to the GPS receiver.)

4.5.2 Setting Power Switch to Timer Mode

1) Setting Power Switch to Timer Mode

Operate the main power switch on the rear side of JAX-9B.

It is necessary to shift the main power switch from the ON state to the Timer mode.
(If the main power switch is shifted from the OFF state to the Timer mode, the timer program recording may fail.)

In case of POWER OFF state:

Push down the main power switch to the right side (POWER ON) on the rear side of JAX-9B.

Confirm that JAX-9B is power ON state.

(The POWER indicator lamp lights up.)

After that, push down the main power switch to the left side (TIMER) on the rear side of JAX-9B.

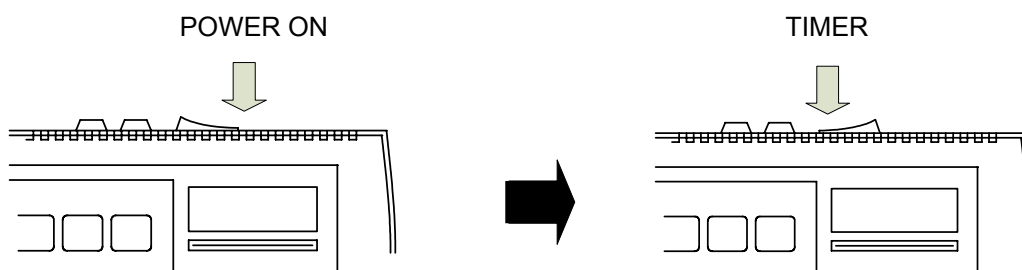

MEMO

JAX-9B is designed to update the next starting time of timer program whenever the main power is set to ON.

If the power is set to OFF, the next starting time of timer program is not updated.

If the main power switch is set from the OFF state to TIMER, the next starting time of timer program is fixed at the last ON mode.

Examples:

The next starting time of timer program is 11:00 → but the power is turned OFF at 10:00
Then, start the timer mode at 12:00 → the next timer program recording starts at 11:00 next day.

2) Panel Indicator

- The TIMER indicator lamp lights up.
- The LCD on the panel does not indicate anything.

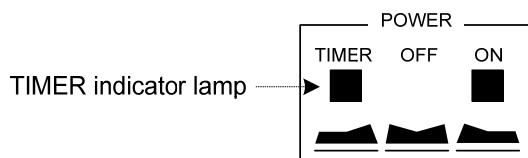





3) Starting Timer

When the starting time of timer program recording comes, the power will be set to ON. In the same manner as when the power is on, the operating status will be indicated on the LCD and the recording will start.

4.5.3 Verifying Timer Program

Verify the registered items of the timer programs.

Operation procedure

- 1)  : Start the timer program registration mode.
- 2)  -  : Enter a program number for verifying.
Program number: 1 to 15, Total 15 channels
- 3) : The registered items of selected timer program will be indicated on the LCD.
- 4)  : End verifying the registered timer program.

• Setting of AUTO mode

■	C	H	=	0	■	1	2	:	0	5	➡	1	2	:	3	5			
■	f	C	H	=	0	5	■	A	U	T	O							■	H

• Setting of MANU mode

■	C	H	=	0	■	1	2	:	0	5	➡	1	2	:	3	5		
■	f	C	H	=	0	5	■	5	7	6	/	1	2	0	■	H		

4.5.4 Modifying Timer Program

The registered timer program can be modified.

Operation procedure

- 1) **PROG** : Start the timer program registration mode.
- 2) **0** - **9** : Enter a program number for verifying.
Program number: 1 to 15, Total 15 channels
- 3) **ENT** n times : The item to be modified will be indicated by “_” (underline).
When pressing the [ENT] switch, the indication position of “_” moves.
Press the [ENT] switch repeatedly until “_” comes to the modifying item.
- 4) ... : Enter new data to modify the present data.
- 5) **ENT** : Confirm the modified data.
- 6) **ENT** n times : Set the half-tone parameter which is the final item.
It is necessary to execute this confirming operation until the final parameter is set.
- 7) **PROG** : Complete the timer program modification and end the timer program registration mode.

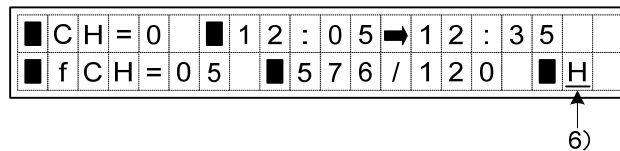

* After confirming the half-tone parameter (by the [ENT] switch), complete the timer program modification.







NOTE

- When an erroneous parameter is inputted in the middle of setting, press the [CLR] switch and re-enter the right parameter.
- Even if the correction of modifying parts that you desire ends, complete the confirmation of all setting (the last item is the registration of half-tone) by pressing [ENT] switch repeatedly. If the confirmation of all items is not completed, registration will be canceled.

4.5.5 Deleting Timer Program

The registered timer program can be deleted.



Operation procedure

- 1)  : Start the timer program registration mode.
- 2)  -  : Enter a program number for verifying.
Program number: 1 to 15, Total 15 channels
- 3) : The registered program of selected channel is indicated on the LCD.
Confirm whether the program is to be deleted or not.
If it is not deleted, omit step 4).
- 4)  : Delete the program display on the LCD.
- 5)  : Delete the selected program from a memory in JAX-9B.
If the [PROG] switch is pushed without pushing the [ENT] switch, the program deleted by “4)” will not be deleted from the memory.
- 6)  : Ends the deleting operation of timer program.

4.5.6 Printing List of Timer Program

The registered timer programs are printed out as a list on recording paper. After registration of the timer programs, verify that there is no error in the registration in referring to the printed list.

Operation procedure

- 1)  : Set the combined function mode.
- 2)  : Start printing the list of timer programs.
- 3)  : Press this key when stopping printing the list.

When the printing of the list is completed, JAX-9B returns to the standby mode automatically.
 → It is unnecessary to execute the end operation.

NOTE • The list of registered timer programs can be printed out on the automatic recording mode of main power operation only. In case of the manual recording mode, change the recording mode to the automatic recording mode.

JAX-9B PROGRAM LIST							
CH	START ~ STOP	FREQ. CH	OPE. MOD	IOC	SCAN	HALF	TIME ERR.
01	13:00~13:30	(01) 3622.5	AUTO.			OFF	
02	15:00~15:30	(02) 7795.0	AUTO.			ON	
03	19:30~20:00	(03) 13988.5	MANU.	576	120	OFF	NG
04	EE:EE~EE:EE	() EEEEE.E	EEEE				
05	23:10~22:40	(00) GROUP	AUTO.			OFF	
06	19:40~20:10	(11) 3622.5	MANU.	288	90	ON	NG
			•				
			•				

If there is an error in the setup time for timer program, the message “NG” will be indicated in the printed list.

4.6 Additional Functions in Accordance with Broadcasting and Reception

The additional functions available for receiving facsimile broadcasting are described below.

- 1) **Adjustment of Inclined Recorded Image** Refer to 4.6.1
- 2) **Halftone Recording** Refer to 4.6.2
- 3) **Reverse Recording of Black/White** Refer to 4.6.3
- 4) **Paper Feed** Refer to 4.6.4
- 5) **Attenuator to Internal Receiver** Refer to 4.6.5
- 6) **Fine Tuning of Receiving Frequency (UP / DOWN)** .. Refer to 4.6.6
- 7) **Switching to External Receiver** Refer to 4.6.7

4.6.1 Adjustment of Inclined Recorded Image

A recorded image may be inclined (deviated) a little to the left or right gradually. In this case, the inclination of the recorded image can be adjusted by using the following control dial:

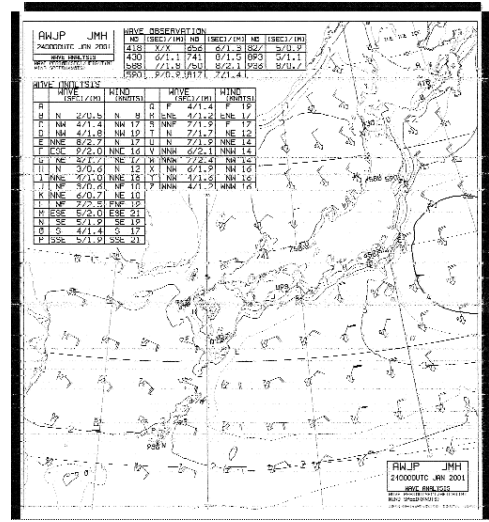
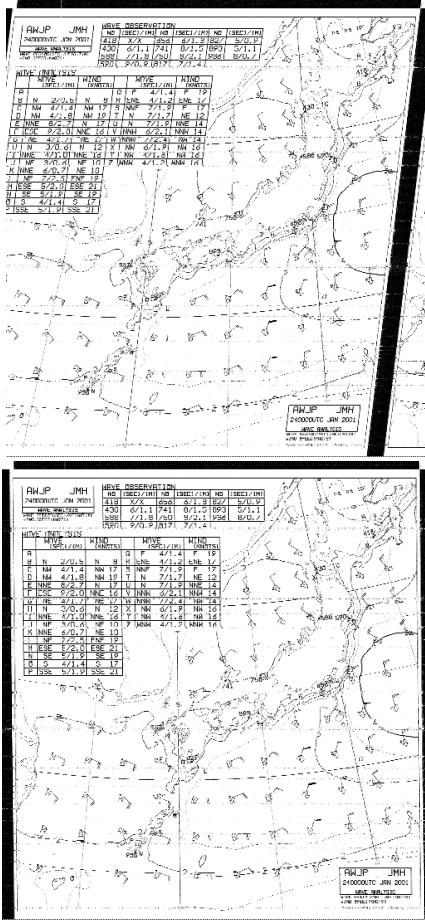

Before adjustment

After adjustment

Operation procedure

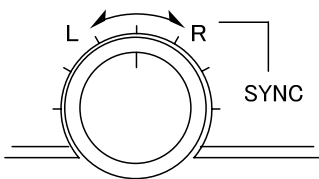

- 1) When the recorded image is inclined to the left:
Rotate the SYNC control dial to the direction of R until the received image is recorded not inclined.
- 2) When the recorded image is inclined to the right:
Rotate the SYNC control dial to the direction of L until the received image is recorded not inclined.

NOTE





- JAX-9B is adjusted so that an image is recorded properly when the SYNC control dial is at around the center position. Adjust it only when the recorded image is inclined (deviated).
- When receiving from the same broadcasting station, the received image is recorded normally after adjusted once, but if the broadcasting station is changed, it might be necessary to make re-adjustment.

4.6.2 Half-tone Recording

In receiving a photo image of a meteorological satellite, the recorded image is clearer in half-tone recording.

Operation Procedure

- 1)  : The half-tone mode can be switched (ON/OFF)

No.	Switch	Indication	Description
1			<ul style="list-style-type: none"> The half-tone mode is valid.
2			<ul style="list-style-type: none"> The half-tone mode is invalid.

NOTE



- In recording texts or weather charts in the half-tone mode, the recorded image may be not clear by dots of background.
Make the half-tone mode invalid normally except receiving satellite photo image.







4.6.3 Reverse Recording of Black/White

Some broadcasting stations broadcast the black/white reversed images (white image in the black background). Please make the black/white reverse recording mode valid when receiving from such FAX broadcasting stations.

Operation Procedure

The reverse (Black/White) recording mode can be switched over (ON/OFF) by the following operations:

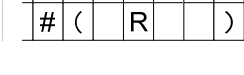
- 1)  : Set the combined function mode.
- 2)  : Switch over the reverse recording mode (ON/OFF).

No.	Switch	Indication	Description
1			<ul style="list-style-type: none"> • Combined function mode. “#” is indicated. When pressing the [#] switch again, the mode is released.
2			<ul style="list-style-type: none"> • The reverse recording mode is valid. “#” is cleared when the setting is completed.
3			<ul style="list-style-type: none"> • Combined function mode.
4			<ul style="list-style-type: none"> • The reverse recording mode is invalid. “#” is cleared when the setting is completed.

4.6.4 Paper Feed

Feed the recording paper to the cut-off position before cutting off the recorded image page.



- 1)  : Feeds the recording paper by 10mm and stops automatically. When pressing this switch again during feeding, the feeding stops.







4.6.5 Attenuator to Internal Receiver

This function can be used when a receiving broadcast is disturbed by external noise or strong radio signals from other broadcasting station.

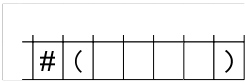
Operation procedure

The attenuator to internal receiver can be switched over (ON/OFF) by the following operations:

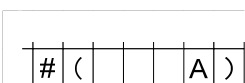
- 1)  : Set the combined function mode.
- 2)  : Switch the setting of the attenuator to internal receiver (ON/OFF).

No.	Switch	Indication	Description
1			<ul style="list-style-type: none"> • Combined function mode. “#” is indicated. When pressing the [#] switch again, the mode is released.
2			<ul style="list-style-type: none"> • The attenuator to internal receiver is valid. “#” is cleared when the setting is completed.
3			<ul style="list-style-type: none"> • Combined function mode.
4			<ul style="list-style-type: none"> • The attenuator to internal receiver is invalid. “#” is cleared when the setting is completed.





NOTE





- The reception sensitivity decreases when the attenuator is used. Therefore, do not use it in the normal condition.

4.6.6 Fine Tuning of Receiving Frequency (UP / DOWN)

The receiving frequency of the internal receiver can be tuned up and down in the steps of 100Hz.

Operation procedure

- 1)  : Set the combined function mode.
- 2)  : Start the receiving frequency tuning (UP/DOWN) mode.
- 3)   :
 - Press the [6] switch, the receiving frequency is tuned up in the steps of 100 Hz.
 - Press the [9] switch, the receiving frequency is tuned down in the steps of 100 Hz.
- 4)  : End the receiving frequency tuning (UP/DOWN) mode.

No.	Switch	Indication	Description																																			
1		<table border="1" style="margin-left: auto; margin-right: auto;"><tr><td>#</td><td>(</td><td></td><td></td><td></td><td>)</td></tr></table>	#	()	<ul style="list-style-type: none"> • Combined function mode. “#” is indicated. When pressing the [#] switch again, the mode is released. 																													
#	()																																	
2		<table border="1" style="margin-left: auto; margin-right: auto;"> <tr> <td>U</td><td>P</td><td>=</td><td>6</td> <td>D</td><td>O</td><td>W</td><td>N</td><td>=</td><td>9</td> <td>O</td><td>F</td><td>F</td><td>=</td><td>C</td><td>L</td><td>R</td> </tr> <tr> <td>f</td><td>=</td><td>2</td><td>2</td><td>7</td><td>7</td><td>0</td><td>.</td><td>0</td><td>/</td><td>1</td><td>2</td><td>#</td><td>(</td><td></td><td></td><td>)</td> </tr> </table>	U	P	=	6	D	O	W	N	=	9	O	F	F	=	C	L	R	f	=	2	2	7	7	0	.	0	/	1	2	#	()	<ul style="list-style-type: none"> • Start the receiving frequency tuning (UP/DOWN) mode. 	
U	P	=	6	D	O	W	N	=	9	O	F	F	=	C	L	R																						
f	=	2	2	7	7	0	.	0	/	1	2	#	()																						
3		<p style="text-align: center;">• [6] = 100Hz up</p> <table border="1" style="margin-left: auto; margin-right: auto;"> <tr> <td>U</td><td>P</td><td>=</td><td>6</td> <td>D</td><td>O</td><td>W</td><td>N</td><td>=</td><td>9</td> <td>O</td><td>F</td><td>F</td><td>=</td><td>C</td><td>L</td><td>R</td> </tr> <tr> <td>f</td><td>=</td><td>2</td><td>2</td><td>7</td><td>7</td><td>0</td><td>.</td><td>1</td><td>/</td><td>1</td><td>2</td><td>#</td><td>(</td><td></td><td></td><td>)</td> </tr> </table>	U	P	=	6	D	O	W	N	=	9	O	F	F	=	C	L	R	f	=	2	2	7	7	0	.	1	/	1	2	#	()	<ul style="list-style-type: none"> • Press the [6] switch, the receiving frequency is tuned up in the steps of 100 Hz. • Press the [9] switch, the receiving frequency is tuned down in the steps of 100 Hz. 	
	U	P	=	6	D	O	W	N	=	9	O	F	F	=	C	L	R																					
f	=	2	2	7	7	0	.	1	/	1	2	#	()																						
	<p style="text-align: center;">• [9] = 100Hz down</p> <table border="1" style="margin-left: auto; margin-right: auto;"> <tr> <td>U</td><td>P</td><td>=</td><td>6</td> <td>D</td><td>O</td><td>W</td><td>N</td><td>=</td><td>9</td> <td>O</td><td>F</td><td>F</td><td>=</td><td>C</td><td>L</td><td>R</td> </tr> <tr> <td>f</td><td>=</td><td>2</td><td>2</td><td>7</td><td>6</td><td>9</td><td>.</td><td>9</td><td>/</td><td>1</td><td>2</td><td>#</td><td>(</td><td></td><td></td><td>)</td> </tr> </table>	U	P	=	6	D	O	W	N	=	9	O	F	F	=	C	L	R	f	=	2	2	7	6	9	.	9	/	1	2	#	()			
U	P	=	6	D	O	W	N	=	9	O	F	F	=	C	L	R																						
f	=	2	2	7	6	9	.	9	/	1	2	#	()																						
4		<table border="1" style="margin-left: auto; margin-right: auto;"> <tr> <td>W</td><td>a</td><td>i</td><td>t</td><td>i</td><td>n</td><td>g</td> <td>s</td><td>t</td><td>a</td><td>r</td><td>t</td> <td>s</td><td>i</td><td>g</td><td>n</td><td>a</td><td>l</td> </tr> <tr> <td>f</td><td>=</td><td>2</td><td>2</td><td>7</td><td>6</td><td>9</td><td>.</td><td>9</td><td>/</td><td>1</td><td>2</td><td></td><td>(</td><td></td><td></td><td>)</td> </tr> </table>	W	a	i	t	i	n	g	s	t	a	r	t	s	i	g	n	a	l	f	=	2	2	7	6	9	.	9	/	1	2		()	<ul style="list-style-type: none"> • End the receiving frequency tuning (UP/DOWN) mode.
W	a	i	t	i	n	g	s	t	a	r	t	s	i	g	n	a	l																					
f	=	2	2	7	6	9	.	9	/	1	2		()																						

NOTE



• JAX-9B does not accept any other switch during the receiving frequency tuning mode. Do not forget to EXIT this mode for carrying out other operations when the tuning operation is completed.







4.6.7 Switching to External Receiver

JAX-9B can be connected to external HF receiver to receive facsimile broadcasting.

Operation Procedure

The external receiver mode can be switched over (ON/OFF) by the following operations:

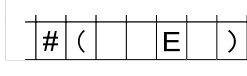
- 1)  : Set the combined function mode.
- 2)  : Switch the setting of the external receiver mode (ON/OFF).

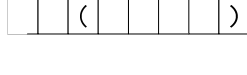
No.	Switch	Indication	Description
1			<ul style="list-style-type: none"> • Combined function mode. “#” is indicated. When pressing the [#] switch again, the mode is released.
2			<ul style="list-style-type: none"> • The external receiver mode is valid. “#” is cleared when the setting is completed.
3			<ul style="list-style-type: none"> • Combined function mode.
4			<ul style="list-style-type: none"> • The external receiver mode is invalid. “#” is cleared when the setting is completed.

4.7 Necessary Functions for Normal Operation of Facsimile

The functions necessary for normal operation of JAX-9B are described below.

- 1) **Setting Internal Clock** Refer to 4.7.1
- 2) **Adjusting the Brightness of Operation Panel** Refer to 4.7.2
- 3) **Language (English / Japanese) on the LCD** Refer to 4.7.3
- 4) **Software Version Display** Refer to 4.7.4

4.7.1 Setting Internal Clock





Set the time of the internal clock.





The time is important parameter for timer program recording. If the time is not set right, the timer program recording will be disabled. It is necessary to correct the time of the internal clock periodically.

MEMO

• When a GPS receiver is connected to JAX-9B, the time of the internal clock is corrected automatically. However, in order to register the standard time to the internal clock, it is necessary to set the time of the internal clock manually only once after connecting to the GPS receiver.

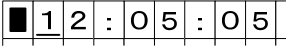
Operation procedure

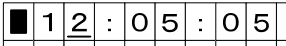
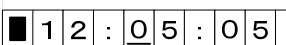
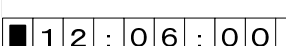
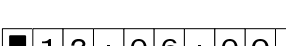
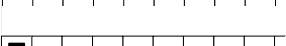
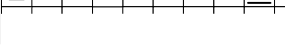
- 1)  : The current time of the internal clock is indicated in the 24-hour basis.
- 2)  -  : Input the time several ten seconds ahead from the actual current time.
- 3)  : Press [ENT] switch, when the input time matches to the current time.
- 4)  : End the current time indication mode.

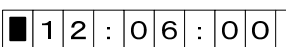
No.	Switch	Indication	Description
1			<ul style="list-style-type: none"> Start the current time indication mode. Displays current time of built-in clock.
2	 	Set the time 12:06:00. [1]:  [2]:  [0]:  [6]:  [0]:  [0]: 	<ul style="list-style-type: none"> Input the time that you desire to set. <p>The "_"(underline) is indicated on the digit to be input. "_" moves to the right when the numerical value is input.</p>
3			<ul style="list-style-type: none"> Confirm the input time. Press [ENT] switch when the input time comes

4		W a i t i n g s t a r t s i g n a l f = 2 2 7 6 9 . 9 / 1 2 ()	• End the current time indication mode.
---	---	--	---

NOTE

• When the built-in lithium battery (approx. 5 years) runs out, the timer should be set again after replacing the battery.

4.7.2 Adjusting Brightness of Operation Panel

The brightness of the backlight of the operation panel can be adjusted.

Operation procedure

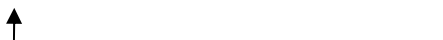

- 1)  : The brightness is adjusted by pressing this switch.
The brightness is adjustable in 4 levels.
OFF → Dark → Medium → Bright



4.7.3 Language (English / Japanese) on the LCD

The display language (Japanese/English) on the LCD can be switched over.



Operation procedure

- 1)  : Set the combined function mode.
- 2)  : Switched over display language.
Japanese → English English → Japanese
- 3) Power switch : Turn OFF the power once and turn it ON again.
The display language switches by restarting the power.

4.7.4 Program Version Display

The program version of JAX-9B is indicated on the LCD.

Operation procedure

- 1)  : Set the combined function mode.
- 2)  : The program version number is indicated on the LCD.

* The program version display automatically disappears after about 5 seconds indication.

Version: The following example indicates “CPU: 1.1.0” and “DSP: 1.0.0”.

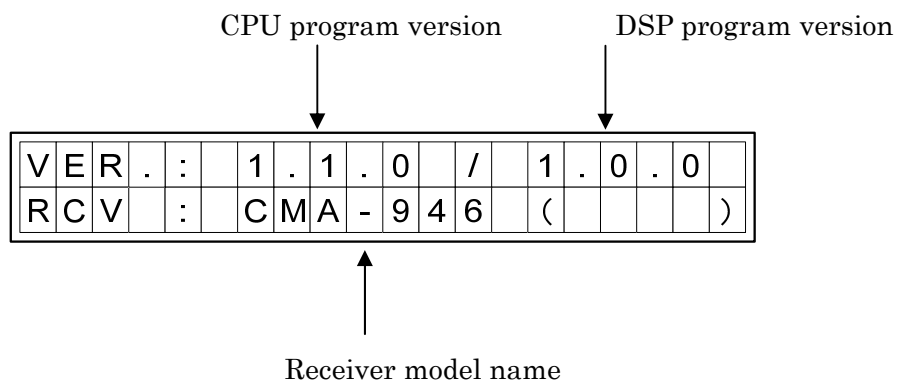

4.8 Alarm Indications

If any trouble occurs in this equipment, it is indicated on the LCD.
In such case, check on the alarm item and take necessary step.

- 1) **No Recording Paper** Refer to 4.8.1
- 2) **BK Signal Input** Refer to 4.8.2
- 3) **Life of Backup Battery (Clock Error)** Refer to 4.8.3

4.8.1 No Recording Paper

When the recording paper is used up, the LCD indicates the message as shown below.

Then, it is necessary to replace it with a new roll of recording paper.

For the procedure of replacing it, refer to Section 5.1.

Press [CLR] switch for deleting the alarm display when printing on the recording paper is unnecessary.

It can be used only for displaying the received images on PC. (Optional function)

P	a	p	e	r	e	m	p	t	y	!	!						
P	o	w	e	r	o	f	f	&	S	e	t	p	a	p	e	r	.

4.8.2 BK Signal Input

The BK signal input is indicated on the LCD.

During the BK signal input, the antenna line is disconnected so that the receiving and recording are suspended.

A	U	T	O	.	5	7	6	/	1	2	0					B	K	!
f	=	2	2	7	7	0	.	0	/	1	2		()	

MEMO

- “BK” is an abbreviation of “BREAK”, which means the disconnection of the antenna from JAX-9B.

If JAX-9B is installed with a radio transmitting equipment such as an HF transceiver, the BK signal sent from the transceiver disconnects the antenna from JAX-9B to protect the internal receiver against the transmitting radio wave from the transceiver.

4.8.3 Life of Backup Battery (Clock Error)

1) The indication of the life of backup battery

When turned on JAX-9B and “Clock error” message is displayed on the LCD, it means that the backup battery has run out. In this case, replace the battery by referring to Section 5.3.

C	I	o	c	k	E	r	r	o	r	!	!								
S	e	t		t	h	e		c	l	o	c	k	.						

NOTE

- If the electronic power supply to JAX-9B is suspended with run-out backup battery, the internal clock loses accuracy.
Set the time of internal clock again when JAX-9B is turned on.
- If a GPS receiver is connected to JAX-9B, the “Clock error” message will not be indicated because the time of the internal clock is set by the GPS data.
- The backup battery backs up the internal clock only. Therefore, the registered frequency channels and timer programs are not cleared even if the battery runs out. The life of the battery is approximately 5 years.

Chapter 5 Maintenance

WARNING



Do not attempt inspections or repairs on the internal part of the equipment by yourself. Inspections or repairs by anyone other than qualified maintainers may result in a fire or an electric shock.

Ask for internal inspections or repairs of the equipment to the Sales Department of JRC, the nearest branch company, branch office, sales office, or any agents of Japan Radio Co., Ltd.

5.1 Replacing Recording Paper

CAUTION



Use the recording paper (6ZPTS00108) as specified by JRC.

The use of any other unspecified paper may cause recording density blurs, abnormal paper feed, much dust, resulting in the damage of the recording device.



Do not store the recording paper in a place exposed to a high temperature, high humidity or direct sunlight. Otherwise, recording density blurs may be caused.

When the remaining section of the recording paper is approximately 2m long, a red ending mark appears on it. Then, prepare for replacing the recording paper.

JAX-9B automatically stops when the recording paper is used out, and end-of-paper message appears on the LCD.

Procedure of replacing recording paper

- 1) Turn off the power of JAX-9B.

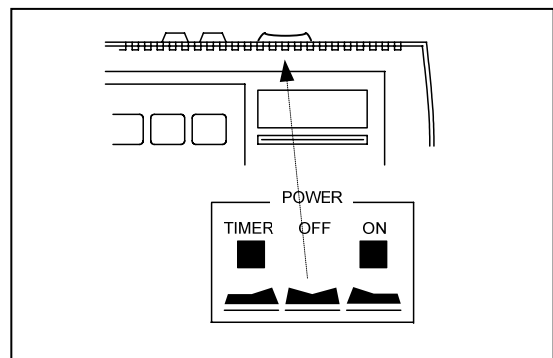

- 2) A red band as ending mark appears.

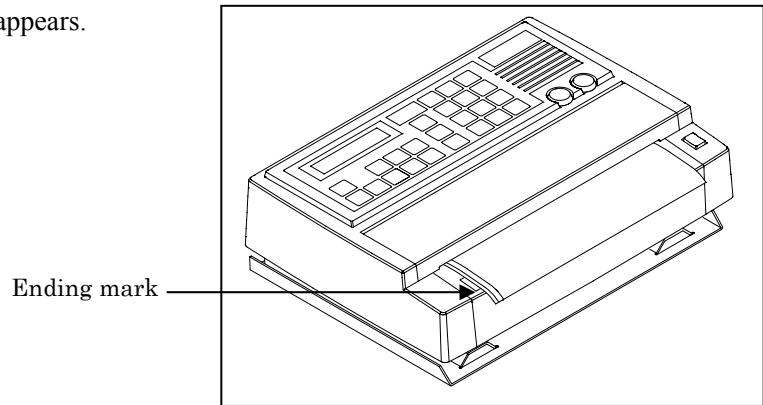

- 3) Press the PUSH OPEN button to open the top cover of JAX-9B.

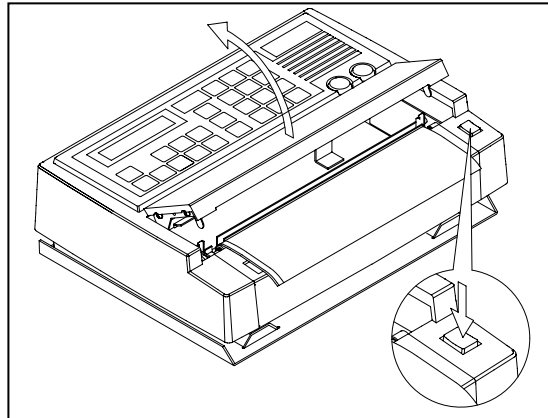

- 4) Open the front cover of JAX-9B. In order to open it, pull the upper part of the front cover toward you while pushing its lower part against the facsimile body.

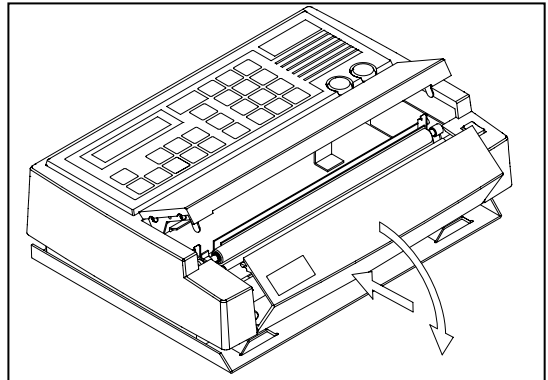

- 5) Remove the core of the used paper roll from the paper holder. Push the core toward the left to remove.

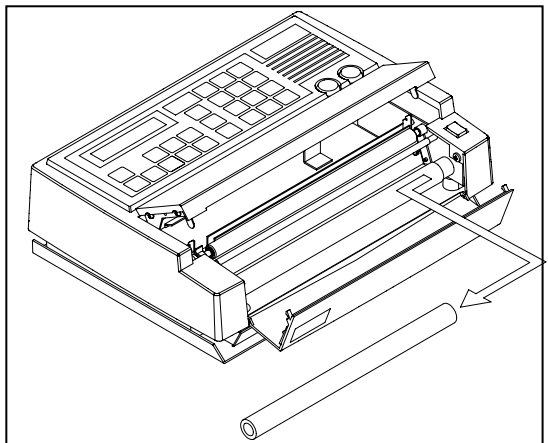

- 6) Put a new recording paper roll in the paper holder and let the recording paper through under the rubber roller as shown below.

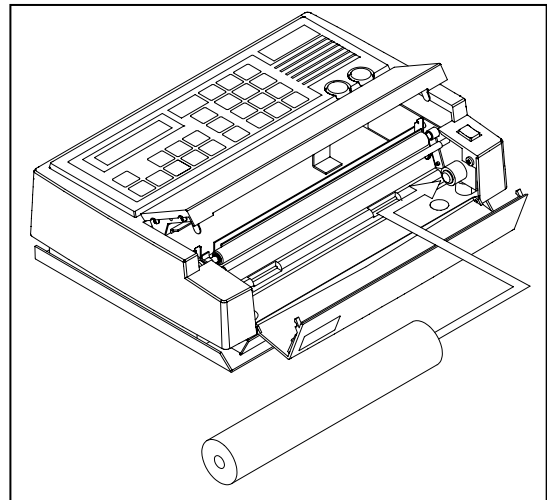
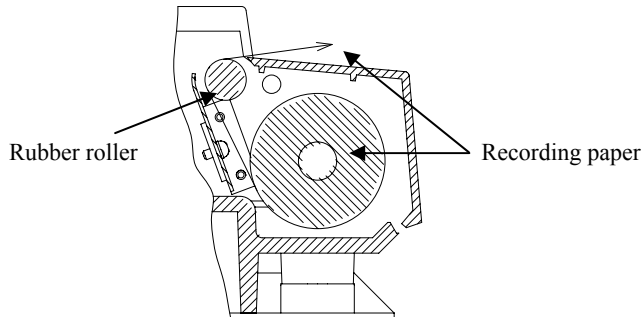

- 7) Pull the leading part of the paper straight toward you. Do not let it slack.

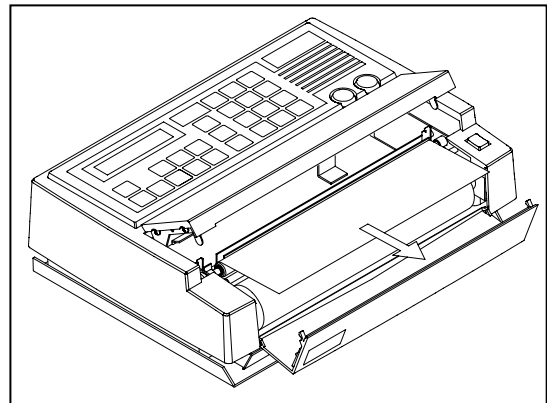

- 8) Close the front cover of JAX-9B while pulling the recording paper.

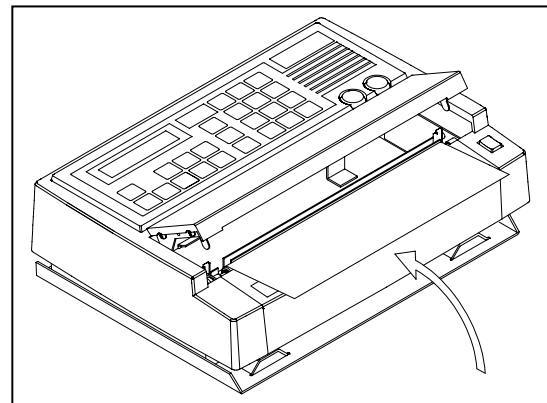

- 9) Ensuring that the paper is well tensioned not to be slack by pulling with one hand, slowly push down the top cover until it is locked with both hands at the end.

Push down the top cover until it is locked with a click.

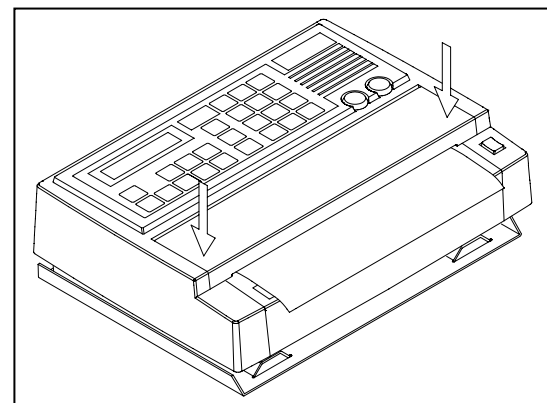

5.2 Cleaning

CAUTION



Clean the thermal head with a piece of soft cloth. Do not rub it with a screw driver or file. Otherwise, the thermal head may be damaged.

JAX-9B is designed for maintenance-free use and does not need much daily work, but JAX-9B should always be kept clean. No smell or dust is generated in recording, but small paper dust is generated a little because the thermal head is contacted onto the recording paper. Therefore, clean the following points once per one month:

Cleaning the thermal head

- 1) Turn off the power of JAX-9B.
- 2) Wipe the heater element of the thermal head lightly with a piece of soft cloth moistened with alcohol.

NOTE

- Tap and wipe the thermal head lightly not to apply an excessive force to it.
- Do not touch the exposed silicon resin that seals the IC chip (at the front end of the cover).

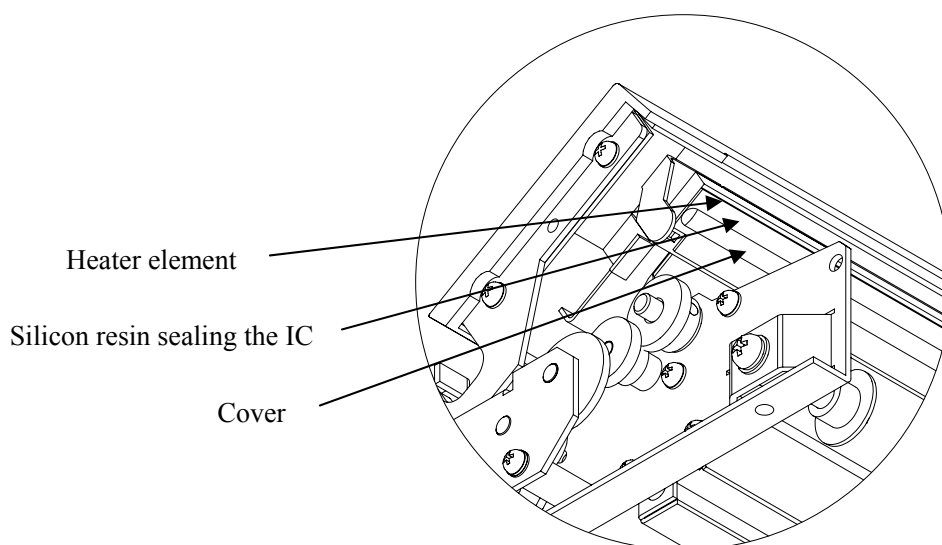

Recording mechanism (viewed from the front side with the top cover opened)

5.3 Replacing Backup Battery

CAUTION



The user may not replace the backup battery.
Even if the POWER switch on the equipment is set to OFF, some parts may remain electrically charged, causing an electric shock or failure.
For replacing the backup battery, contact a nearby JRC marketing office, branch, sales office or agent.



Use the JRC-specified backup battery (CR2032-type lithium battery).
The use of any unspecified battery may cause a malfunction or failure of the equipment.

1) Replacing backup battery

If "Clock Error!!" is displayed when JAX-9B is powered on, it's the time to replace the battery.
For replacing the backup battery, contact a nearby JRC marketing office, branch, sales office or agent.

5.4 Troubleshooting

If JAX-9B has a failure, it should be diagnosed by an authorized service engineer to replace any defective part. However, the user can shoot the simple troubles referring to the table below.

Trouble symptom	Cause	Action	Refer to
Paper feed and recording are impossible.	The recording paper is tilted or slackened and deviated from the paper sensor.	Set the recording paper properly.	P71
	Unlocked the top cover. (Mechanism part with the thermal head)	Push down the top cover firmly until it is locked with a click.	P73
	The paper sensor (left below the rubber roller) is contaminated with paper dust.	Clean the paper sensor carefully.	P74
Recording does not start.	The parameter SCAN SPEED is erroneous.	Adjust the SCAN SPEED.	P39
	The receiving condition is no good.	Change the frequency to the good receiving condition.	P26
	The register operation of a timer program has not been completed. The display of LCD is still a program mode.	Press the [PROG] switch. The timer program mode is finished.	P49
Printing becomes blurred or falls out.	The thermal head is not cleaned.	Clean the thermal head.	P74
The timer program receiving does not start.	"Clock Error!!" is displayed when JAX-9B is powered on.	Set the correct time. Replace the backup battery.	P65 P75
	The internal clock is set an incorrect time.	Set the correct time.	P65
	The POWER switch is switched over from OFF to TIMER.	Set the POWER switch to ON before setting it to TIMER.	P52
	The program contents contain any errors.	Check the timer program list by printing. Correct the program.	P56 P54
	The receiving start time is overlapped for two or more programs.	Check the "ERROR" message in the printed timer program list. Correct the program with "NG" message	P56 P54

Trouble symptom	Cause	Action	Refer to
The [MANU] switch is not accepted.	The register operation of a timer program has not been completed. The display of LCD is still a program mode.	Press the [PROG] switch. The timer program mode is finished.	P49
The [FEED] switch is not accepted.	Time is indicated on the LCD.	Press the [CLK] switch. The timer mode is finished.	P65
The [CLOCK] switch is not accepted.	The register operation of a timer program has not been completed. The display of LCD is still a program mode.	Press the [PROG] switch. The timer program mode is finished.	P49
The [PROG] switch is not accepted.	Time is indicated on the LCD.	Press the [CLK] switch. The timer mode is finished.	P65

Chapter 6 Connection of GPS Receiver

JAX-9B can correct the internal clock automatically by receiving the time data outputted from a GPS receiver. Connecting a GPS receiver to JAX-9B is recommended if the timer program recording is used. Doing so will make it unnecessary to correct the time of the internal clock periodically. Even if the backup battery in JAX-9B runs out, JAX-9B can continue normal operation by receiving the time data outputted from the GPS receiver.

- MEMO**
- The lithium battery in JAX-9B is used to back up the internal clock. The internal clock can continue to indicate the right current time by receiving data from the GPS receiver, even if the battery cannot back up the internal clock.

6.1 GPS Receiver Connection Interface

JAX-9B supports a connection interface as follows:

For connecting a GPS receiver, consult with the manufacturer of the GPS receiver about the data output interface of the GPS receiver.

No.	Item	Specification
1	Communications I/F	NMEA standards
2	Baud rate	4800bps
3	Data format	NMEA standards Ver. 2.0 or following
4	Received data	ZDA or RMC The above sentence contains time data.
5	JAX-9B interface port	P102 Rx-: 7pin Rx+: 8pin
5	GPS Receiver interface port	Consult with the manufacturer of the GPS receiver

- MEMO**
- GPS receivers designed for ship use can satisfy the above interface. However, it is required that the GPS receiver is provided with an output port connectable to JAX-9B. If the GPS receiver has no port for connecting JAX-9B, contact a JRC marketing office, branch, sales office or agent.

6.2 Operation Check

The automatic time correction is performed only by connecting a GPS receiver to JAX-9B.
 (It is unnecessary to set up JAX-9B.)



1) Timing for automatic time correction

The automatic time correction is performed at the following timing, but the LCD indicates no message of the time correction completing.

- Power ON
- Timer program recording starts
- Completes the facsimile image recording

2) Operation check

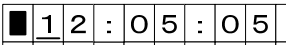
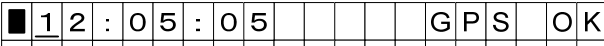
Confirm that the "GPS OK" message is indicated on the LCD. Start the current time indication mode and this message is indicated when the automatic time correction is completed normally by received data from the GPS receiver.

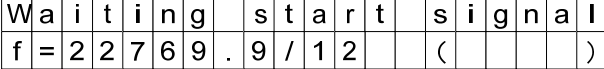
No.	Switch	Indication	Description
1			<ul style="list-style-type: none"> • Start the current time indication mode.
2			<ul style="list-style-type: none"> • "GPS OK" message is indicated on the LCD when the automatic time correction is completed normally.
3			<ul style="list-style-type: none"> • Stop the current time indication mode.

Chapter 7 The Viewer Software (Optional)

The Viewer software is designed to display the real-time image received by the JAX-9B on the personal computer monitor, and automatically save it as a file after the reception.

7.1 Features

7.1.1 Real time image display and automatic file saving

The Viewer software is designed to display the real-time image received by the JAX-9B on the personal computer monitor, and automatically save it as a file after the reception.

7.1.2 Image file management and file opening

The date and time are added to the saved image file as a filename. When receiving images in the timer program mode, the Viewer software can add to the "Program ID" as a filename. The Viewer software can classify and save the image file into the subfolder by "Date" or "Program ID". The saved image files are easily searched, and can be opened.

7.1.3 Operation without the recording paper

Without the recording paper, the JAX-9B transmits the image data to the personal computer. So, the reception on the personal computer succeeds.

7.1.4 Printing the image

The Viewer software can print out the received image or the opened image file with the printer connected to the personal computer. Also, the Viewer software can divide and print out a long image.

7.1.5 Registration of settings

The Viewer software can register the frequency channel settings and the timer program settings from the personal computer to the JAX-9B. Also, the Viewer software can save the setting data as a file in the personal computer.

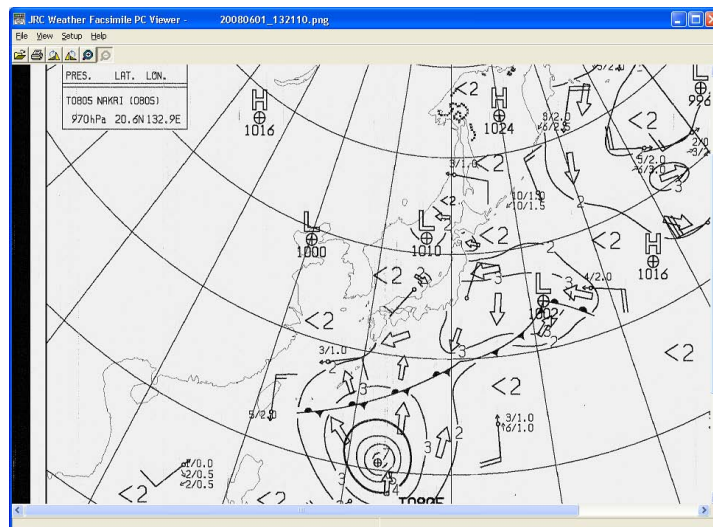

7.2 Option Kit

For using the optional function, it is necessary to add the following option kits to JAX-9B.

1	FAX image display kit	7ZZNA4017	Personal computer software for displaying the image Communication I/F Unit *1
2	Viewer Software Instruction Manual	7ZPNA4124C	English

NOTE

- The personal computer should be prepared by the customer.
- Request the installation of the option cable and the converter to our service person.

- *1 The unit that converts the JAX-9B RS-422 signal into USB signal.
- The personal computer requires to be equipped with USB 2.0 port.
 - The length of the USB cable attached to the converter is 1m. Set up this converter near the personal computer.

7.3 Setting Up Options

- For performing the optional function, it is unnecessary to operate JAX-9B.
The optional function is performed only by connecting the option kits and a PC to JAX-9B.
- The image transmitted to PC is the image being recorded on JAX-9B.
If the image does not need to be recorded, remove the recording paper roll from JAX-9B. Then, JAX-9B will not record because there is no paper, but will transmit the received image to PC. In this case, the error message displays on the JAX-9B LCD and the JAX-9B key switches become inoperative. The [CLR] key switch is pressed, it returns to the normal display and to be operative.

Chapter 8 Operating Environment

Note the following points to keep the operating environment in which JAX-9B can operate normally:

- If JAX-9B is exposed to the direct sunlight, the inside temperature will become extraordinarily high. Install JAX-9B indoors where it is not exposed to the direct sunlight.
- This JAX-9B is not designed to provide a waterproof or water-drip structure. Install JAX-9B indoors where it is not affected by winds, water or sandy dust.
- Protect JAX-9B with the attached protective cover against dust and the like when it is not used for a long time.

Chapter 9 Customer Support

When requesting the repair or replacement

If you suspect a malfunction of JAX-9B, check it again referring to “Chapter 5 5.4 Troubleshooting”. If the problem persists even after troubleshooting, stop using it and consult with our sales agency where you purchased the product, JRC business department, nearby JRC regional branch, branch, or agency.

- The repair service during the warranty period is made free of charge by our sales agency or JRC, if the equipment is operated properly (in the normal operating conditions) in accordance with this *Instruction Manual*.
However, you will be charged for any malfunctions caused by the wrong use, fault, the inevitability beyond human control such as the natural disaster and fire.
- We provide the repair outside of the warranty period and the replacement of consumables for a charge upon the customer’s request.

List of Consumables

No.	Product name	Model	Expected life span
1	Thermal head	WQ256-Q1(H)	Service life of printing 30km *1
2	Battery	CR2032	Approx. 5 years
3	Recording paper role	6ZPTS00108	25m / role

*1 Expected life span of thermal head
 Service life of printing: 30km
 B4-size paper: 256×364 [mm]
 When recording 20 pages of fax images / 1 day
 $30000 / (364 / 1000 \times 20) = \text{Approx. 10 years}$

- Information need to be given with your request for repair
 Fill out “JAX-9B Failure Check List” on the following page.
 - ☆ Product name, model, product number or/and serial number
 - ☆ Description of trouble symptom (as detailed as possible.)
 - ☆ Name of customer’s business or organization, location, and telephone number

If you have any unclear points about our after-sale service, consult with our sales agency where you purchased the product, JRC business department, nearby JRC regional branch, branch, or agency.

For inquiries:

Refer to the List of JRC Overseas Offices attached in the end of this manual.

Chapter 9 Customer Support

JAX-9B Failure Check List

When placing an order for repair of the product, you are kindly requested to confirm and fill out the items below, and contact our sales agency or JRC.

Vessel Name: _____ Phone: _____ Fax: _____
 JAX-9B Serial Number _____

Please confirm the following items in numerical order and check either Yes or No by “√”. If an item is not applicable, concretely explain how the fault arose in 18 [Other Items].

No.	Check Items	Results	
		Yes	No
JAX-9B			
1	When the POWER switch is set to ON, the “POWER ON” lamp does not light up.		
2	When the POWER switch is set to TIMER, the “POWER TIMER” lamp does not light up.		
3	No received image is printed out on the recording paper. (The blank recording paper is fed out.)		
4	The density of printed received image is thin.		
5	Some area of printed image is thin (Left/Center/Right).		
6	The recorded image is vertically contracted in the automatic/manual recording mode.		
7	The recorded image is vertically expanded in the automatic/manual recording mode.		
8	The Timer Recording mode does not start.		
9	The receiving (recording) does not start as it remains on the reception stands by.		
10	The alarm of no recording paper is indicated though the recording paper is set.		
11	A specific switch is not acceptable.		
12	No indication appears on the LCD.		
13	The receiving monitor sound of facsimile broadcasting is not audible.		
14	“Clock Error” is indicated on the LCD.		
15	Facsimile receiving (recording) from a specific broadcasting station is not available.		
16	No frequency can be registered.		
17	No timer program can be registered.		
18	[Other Items]: Please describe in detail.		

Chapter 10 Disposal

CAUTION



In returning the run-out lithium battery to JRC, take the insulating treatment such as attaching a tape to the +/- terminals. If the battery is short-circuited with no insulating treatment, a heat, explosion or fire may be caused.

10.1 Disposal of the Equipment

JAX-9B must be disposed of in accordance with the applicable regulations and rules of the local government. For the details, please consult with our sales agency where you purchased the product, nearby JRC regional branch, branch, agency, or the local government.

10.2 Disposal of Used Battery

A lithium battery for backup is used in the Control Unit of JAX-9B.

- Stop electronic power supply to JAX-9B when the used lithium battery is removed. Disconnect TB101 (refer to 3.7 on 20 page) for stopping electronic power supply to JAX-9B.
- Do not dispose of the used lithium battery as a waste material.
- The used lithium battery can be recycled. Please take the insulating treatment such as attaching a tape to the +/- terminals before returning the battery to, or consult a nearby JRC agent or dealer, representative office or any recycle shop.

10.3 About the China RoHS

有毒有害物质或元素的名称及含量 (Names & Content of toxic and hazardous substances or elements)

形式名(Type): JAX-9B

名称(Name): Weather Facsimile Receiver

部件名称 (Part name)	有毒有害物质或元素 (Toxic and Hazardous Substances and Elements)					
	铅 (Pb)	汞 (Hg)	镉 (Cd)	六价铬 (Cr ⁶⁺)	多溴联苯 (PBB)	多溴二苯醚 (PBDE)
天线 (Antenna)	×	○	×	×	×	×
气象? 真接收机 (Facsimile Unit)	○	○	○	○	○	○
外部设备(Peripherals) - 选择(Options) - 电线类(Cables) - 手册(Documentts)	×	×	×	×	×	×
<p>○: 表示该有毒有害物质在该部件所有均质材料中的含量均在SJ/T11306-2006 标准规定的限量要求以下。 (Indicates that this toxic, or hazardous substance contained in all of the homogeneous materials for this part is below the requirement in SJ/T11363-2006.)</p> <p>×: 表示该有毒有害物质至少在该部件的某一均质材料中的含量超出SJ/T11363-2006 标准规定的限量要求。 (Indicates that this toxic or hazardous substance contained in at least one of the homogeneous materials used for this part is above the limit requirement in SJ/T 11363-2006.)</p>						

Chapter 11 Specifications

11.1 Facsimile Functional Ability

- 1) Recording system : Solid-state recording by thermal head
- 2) Recording paper : Thermo-sensitive recording paper
260mm (width) x 25m (length) / roll
- 3) Effective recording width : 256mm (10 inches)
- 4) Index of cooperation : 576 or 288
- 5) Scanning speed : 60, 90, 120, 240 SPM (Scanning / Minutes)
- 6) Scanning resolution : 8dots/mm
- 7) Scanning line density : Approx. 7lines/mm, 3.5lines/mm
- 8) Phase matching : Automatic and manual
- 9) Halftone recording : 16 levels by Dither pattern
- 10) Negative/Positive recording : Manual
- 11) External receiver connection : 0dBm, 600Ω (1900Hz +400Hz / -400Hz)
- 12) Operation modes :
 - Automatic recording
All the operation of IOC selection, scan speed selection, phase matching, recording, paper feed and stop are controlled by the remote control signals in accordance with the WMO Technical specifications.
 - Manual recording
The IOC and scan speed are manually selected and phase matching, recording and stop are automatically controlled
 - Forced recording
All the operations are manually preset.
 - Timer program recording
Recording starting time and finishing time can be programmed.
- 13) Timer Program channels : 15 channels
- 14) Setup data list recording : Receiving frequency list, Timer Program channel list
- 15) Self-test function : Recording test, Panel test
- 16) Automatic time correction : Input the GPS data
- 17) Image data output : Display received image on PC
- 18) Remote maintenance : Connecting to the JRC Remote Maintenance System

11.2 Synthesized Receiver

- 1) Receiving system : Phase-locked type frequency synthesized with up-conversion and double super heterodyne type
- 2) Class of emission : F3C
- 3) Frequency range : 2.0000 - 24.9999 MHz
- 4) Automatic frequency selection: The optimal frequency is selected automatically.
- 5) Receiving frequency memory: Up to 90 channels storing
- 6) Sensitivity : 2 μ V (+6dB μ) or less
for antenna input to obtain the output of -5dBm at 20dB S/N
- 7) IF Selectivity : 6dB down point 2.4 kHz to 3.0 kHz
66dB down point 6 kHz or less
- 8) Image rejection ratio : More than 60dB

11.3 General Specifications

- 1) Power voltage : 12 / 24 / 32 Vdc -10% to +30%
100 / 220 Vac with Rectifier unit (Option)
- 2) Power consumption : 50VA or less
- 3) Dimensions : Approx. 358 (W) x 254 (D) x 107 (H) mm
(Including the mounting base)
- 4) Mass : Approx. 5.3 kg (Including the mounting base)
- 5) Color : N4 (Munsell)

11.4 Environmental Condition

- 1) Operating temperature : Operating range -15 °C to +55 °C
(The print density might become light when using it under -10 °C or less.)

Appendix

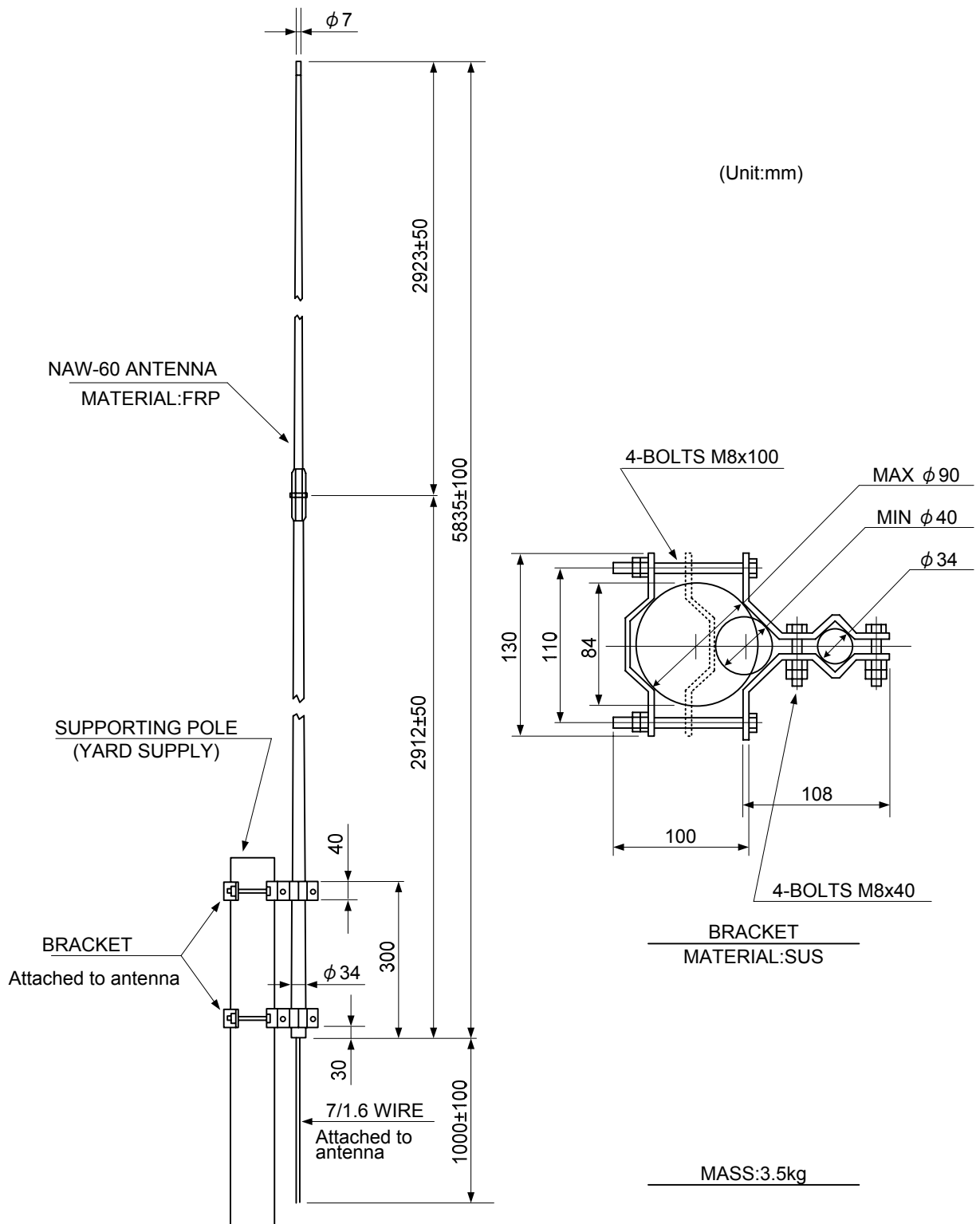

Appendix figure 1. NAW-60 6m Whip Antenna

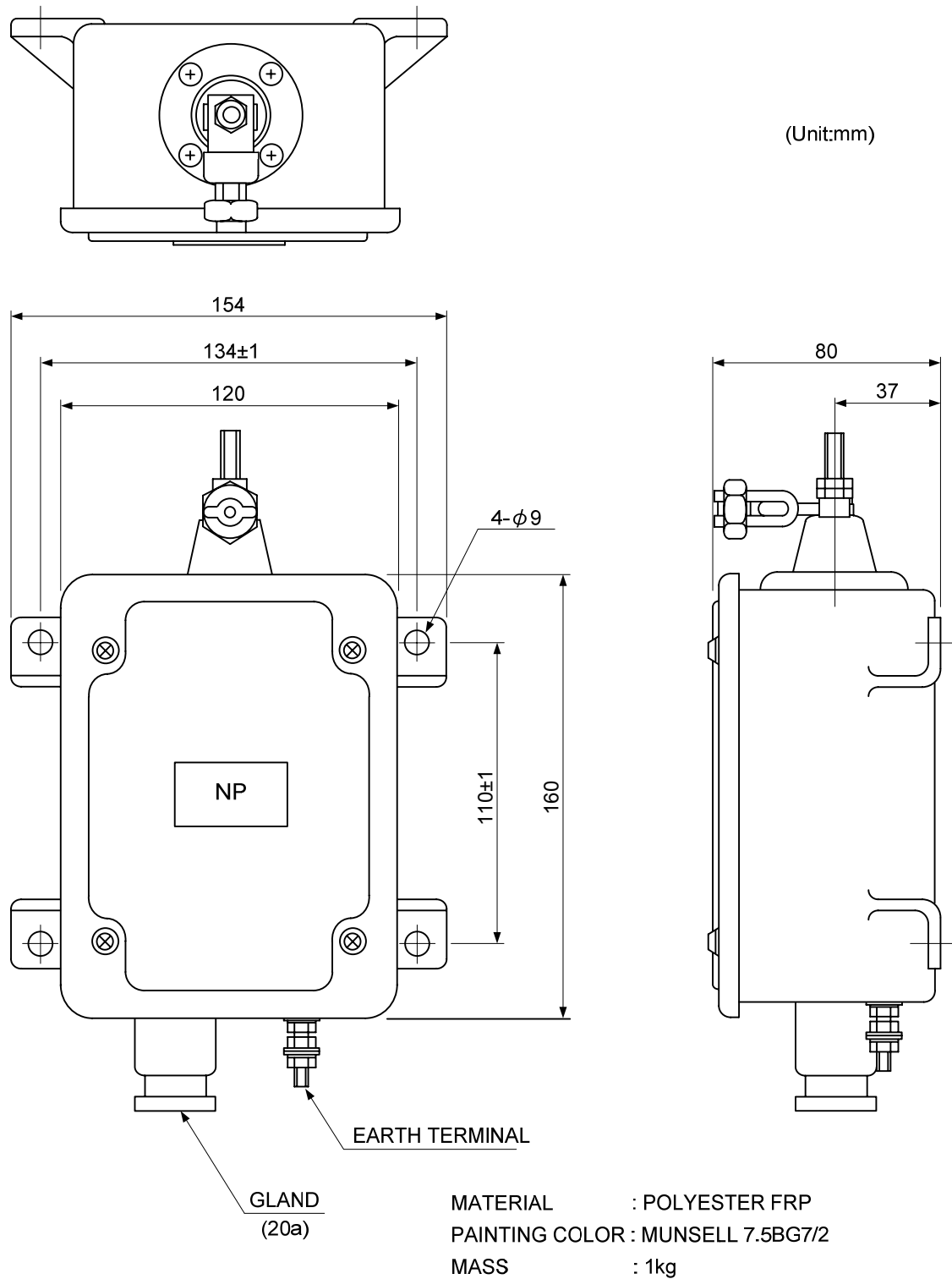

Appendix figure 2. JQD-69C Junction Box

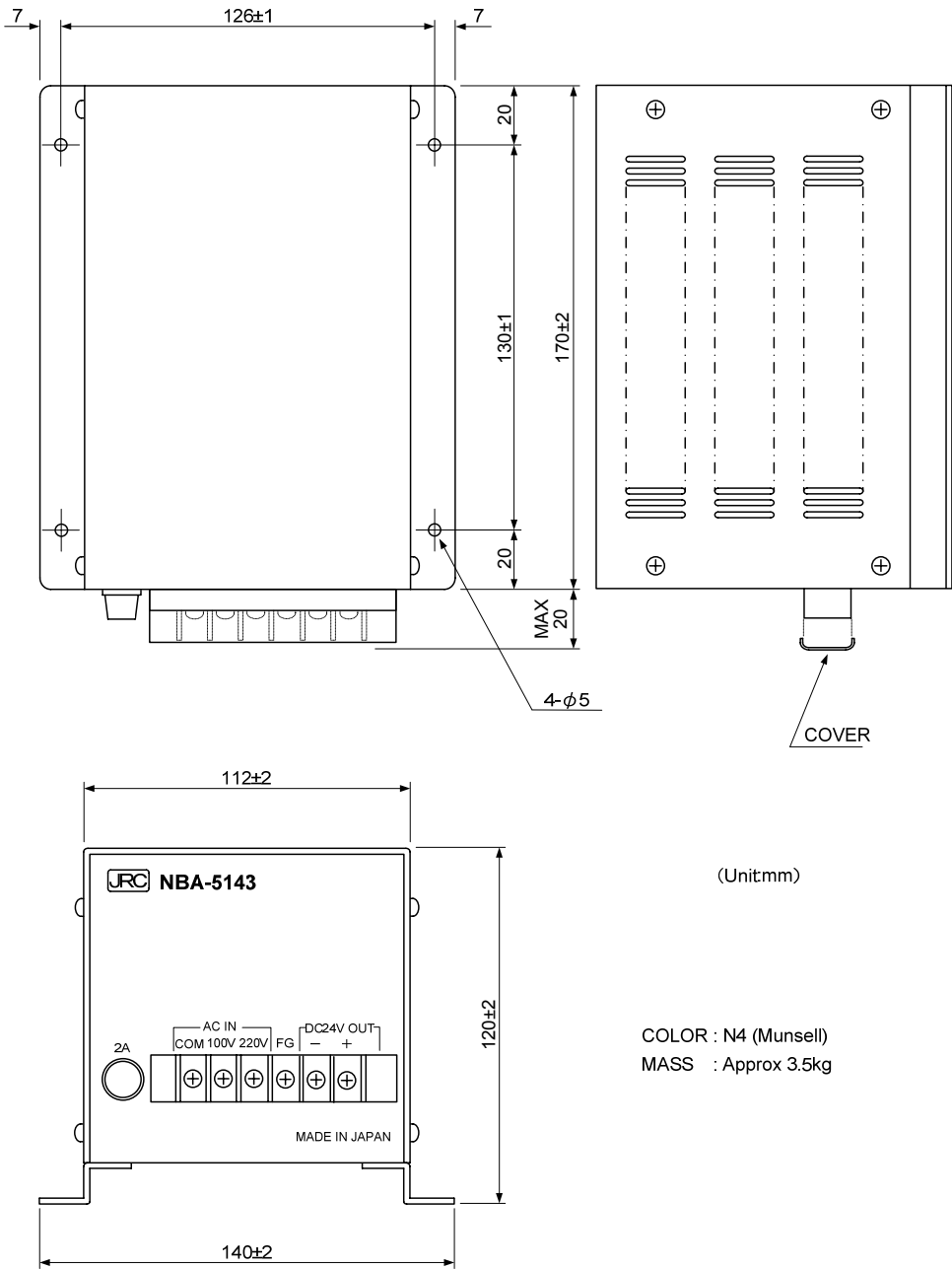

Appendix figure 3. NBA-5143 Rectifier Unit

For reception of clear facsimile images

It often happens that facsimile images are blurred, disturbed or broken during reception. You may think that your facsimile unit becomes defective or has the worse reception sensitivity. Before thinking so, let us study the nature of wave propagation.

The short-waves are all transferred long distance by reflections on the ionosphere that surrounds the earth. The ability of reflection of the ionosphere varies hourly, in seasons, and other surrounding conditions. Therefore the magnitude of radio waves that you receive varies continually. This is why your facsimile pictures are not clear. The short-wave propagation is also dependent upon the frequencies of the short waves. Some frequencies are reflected worse but other frequencies are reflected better.

To use this characteristics, the facsimile broadcasting stations use some frequencies (in the range of 2 to 25 MHz) to broadcast identical broadcasting data. You can select any of the frequencies for optimum reception.

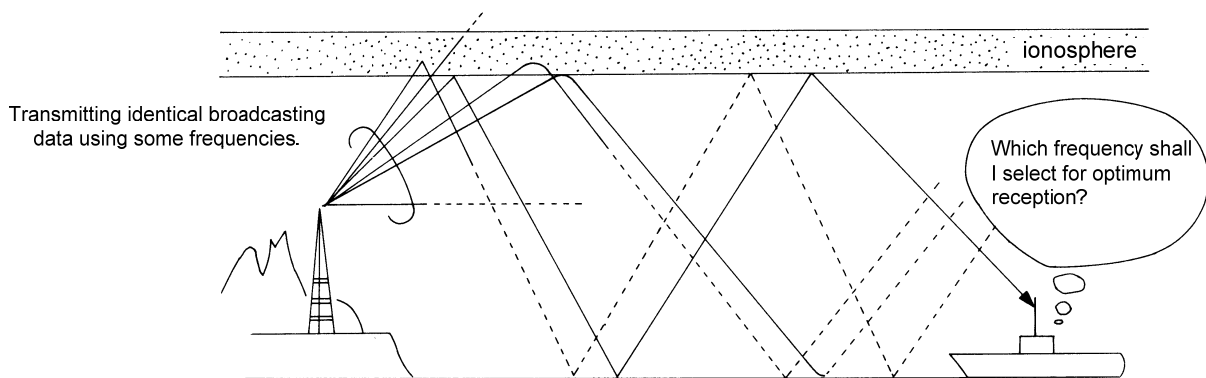

Radio wave troubles in the short-wave band may be caused by multi-path echo, fading, and interference. To receive clear facsimile pictures, it is recommended to select a frequency that is not interfered instead of selecting a strong frequency. The Automatic Frequency Selection function of JAX-9B automatically selects a strong frequency but this is not good enough for clear and optimum picture reception.

Therefore, you have to select a frequency for optimum reception according to the propagation conditions that will be varied in 1) daily (morning, daytime, night), 2) seasonally (spring, summer, autumn, and winter), and 3) distance from the station.

Appendix Figures 4 to 10 show some interfered reception samples.

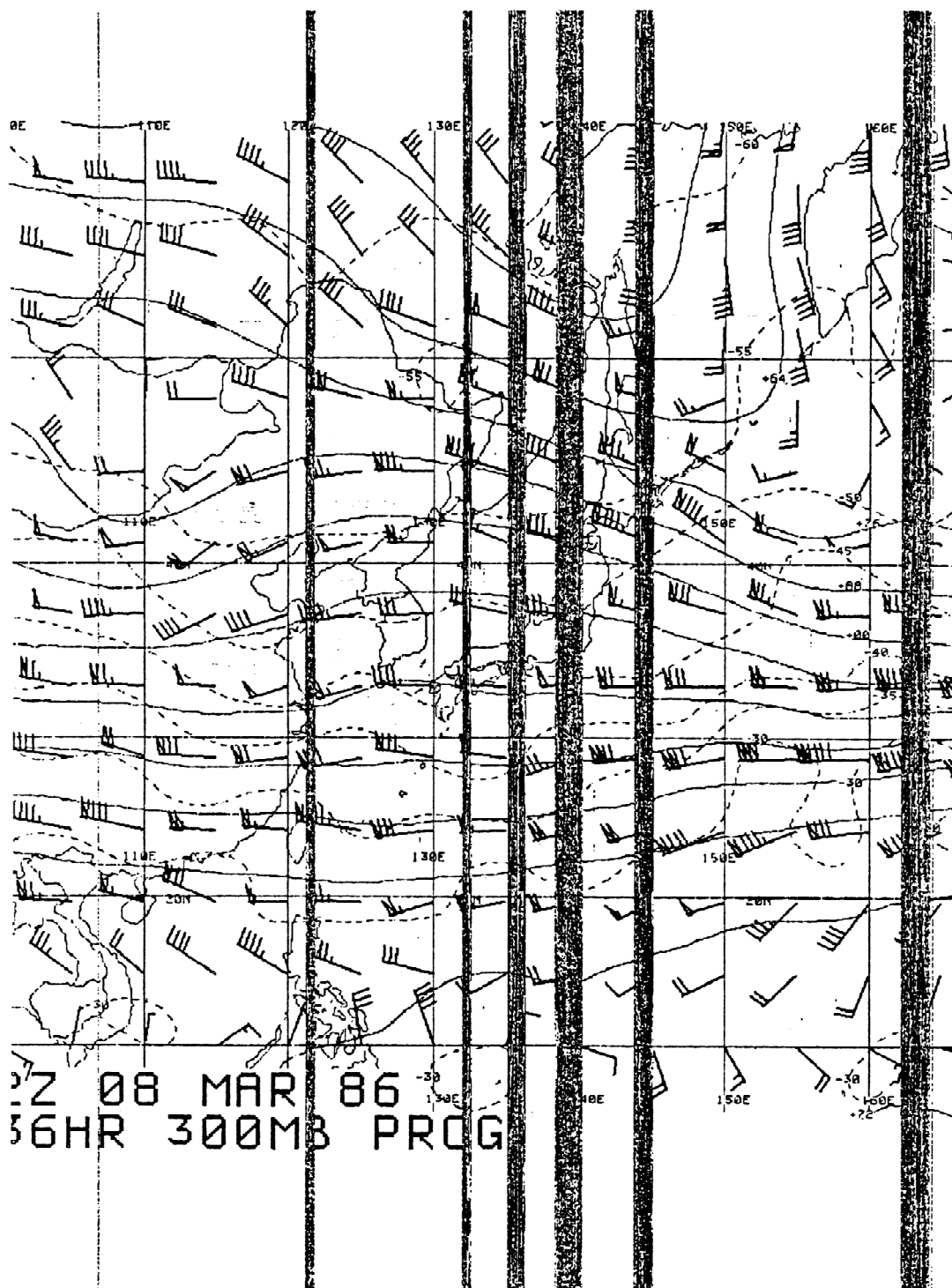

Appendix Figure 4 Interfered reception example 1

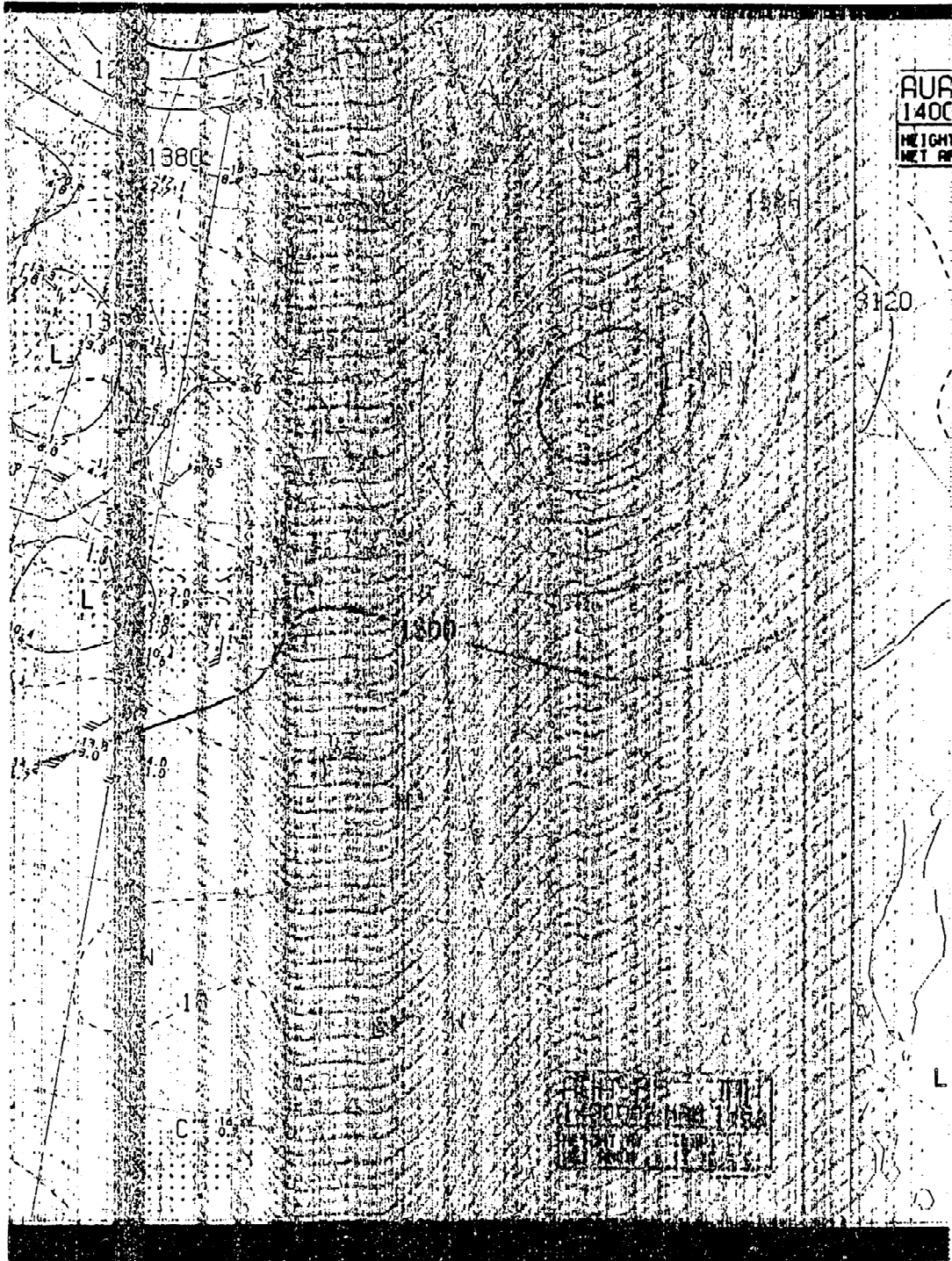

Appendix Figure 5 Interfered reception example 2

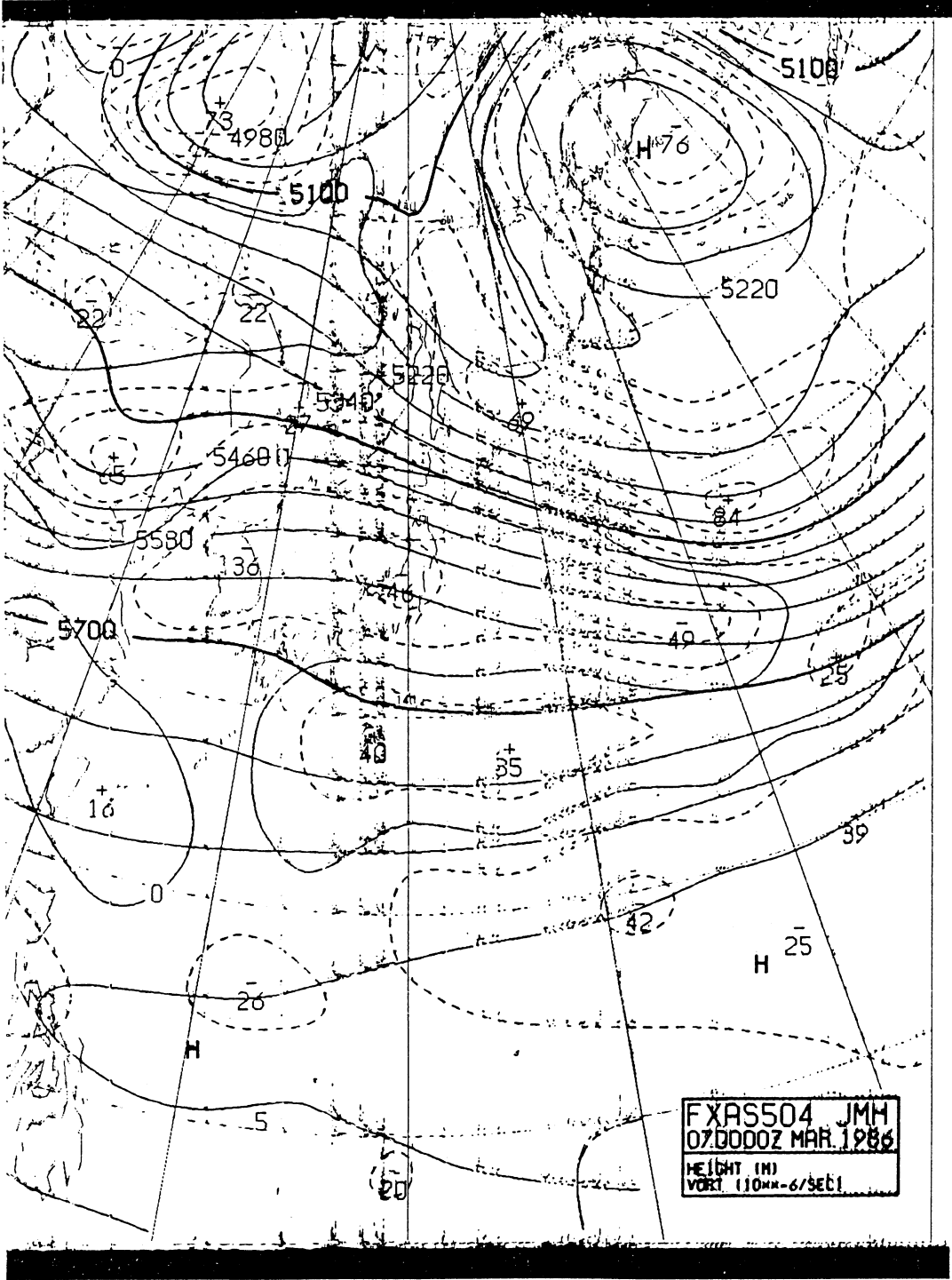

Appendix Figure 6 Interfered reception example (Multi-path echo)

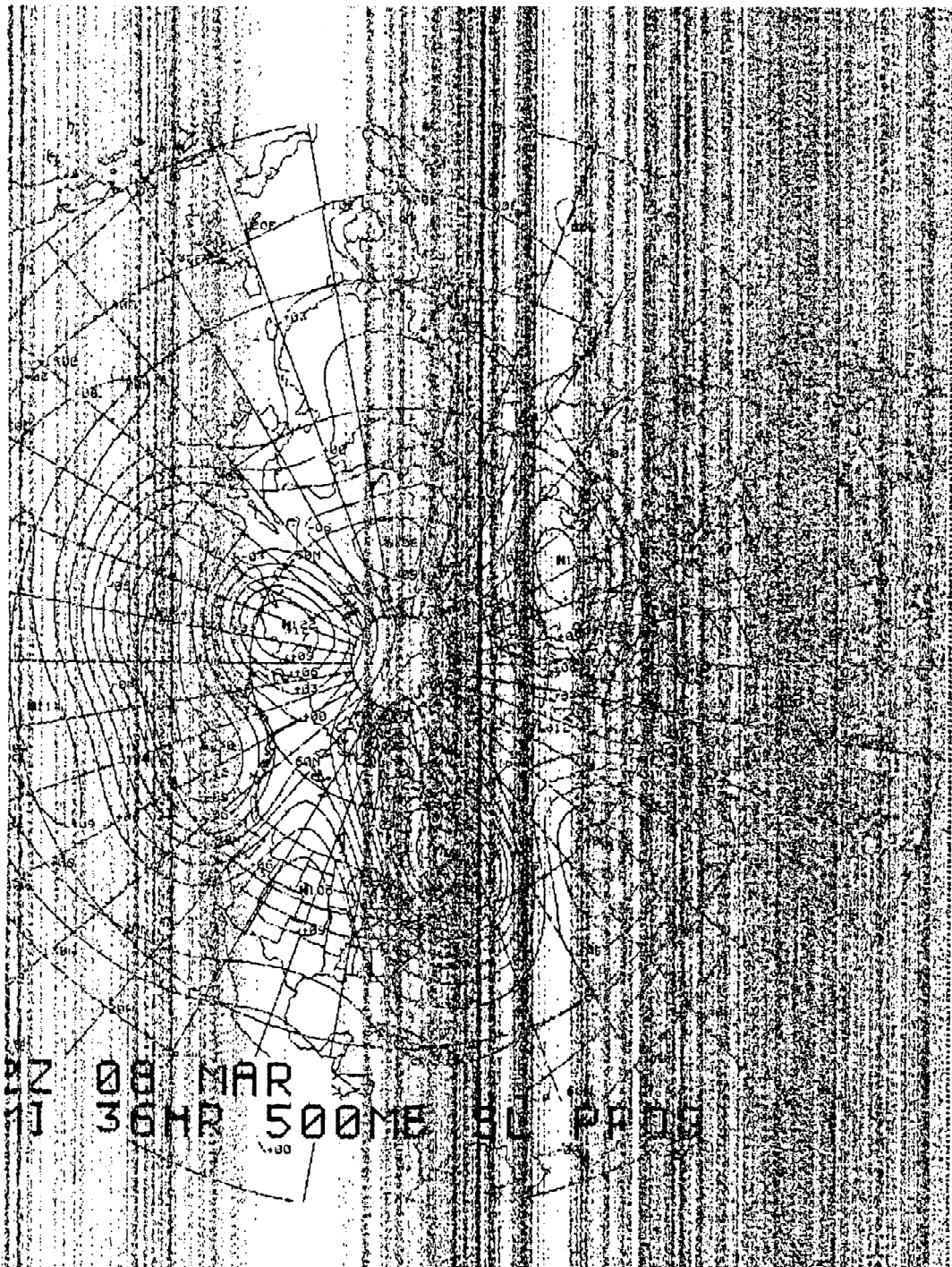

Appendix Figure 7 Interfered reception example (Fading)

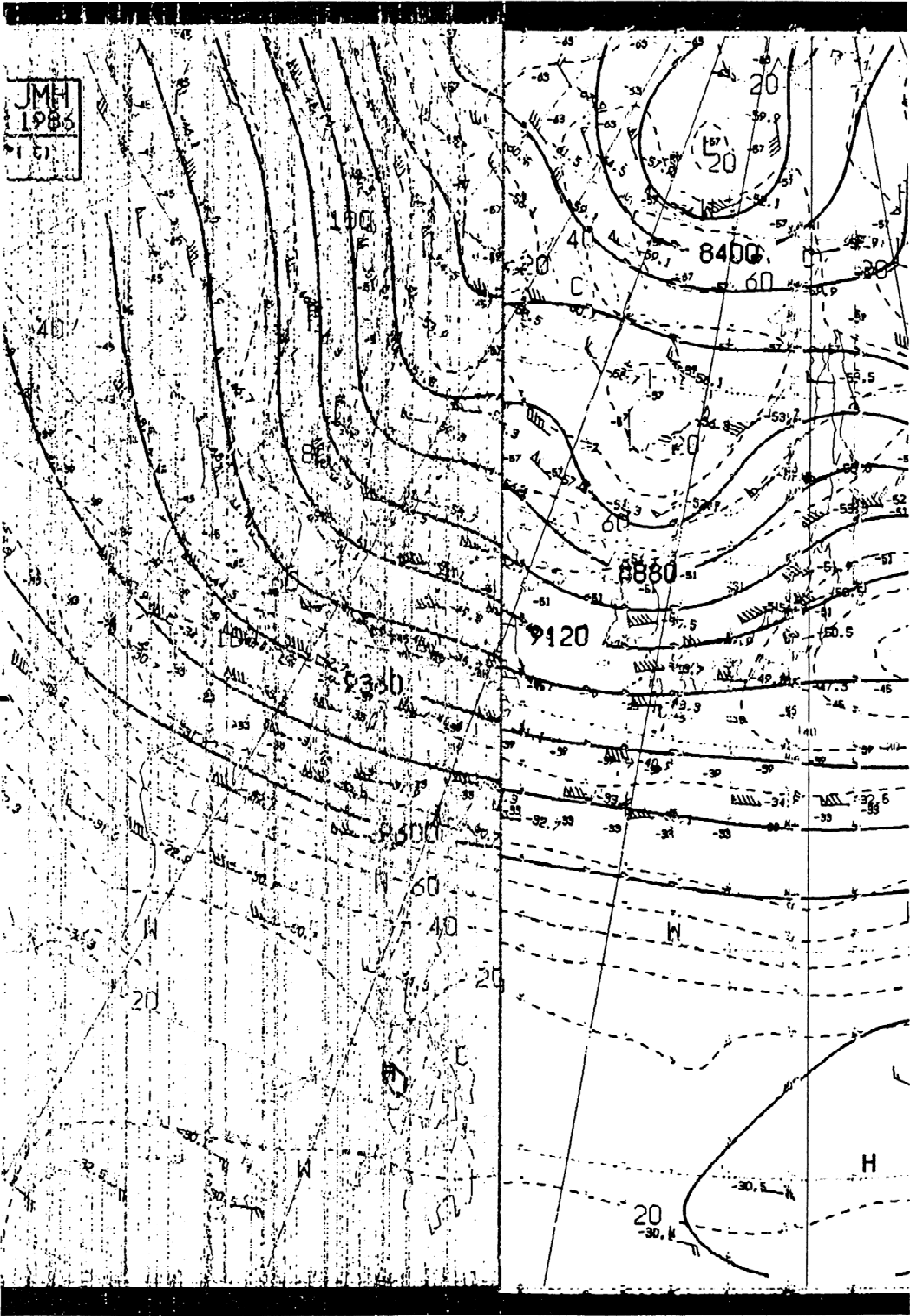

Appendix Figure 8 Interfered reception example (Different reception frequencies)

Execution of the Automatic Frequency Selection function

The wave propagation condition goes worse.

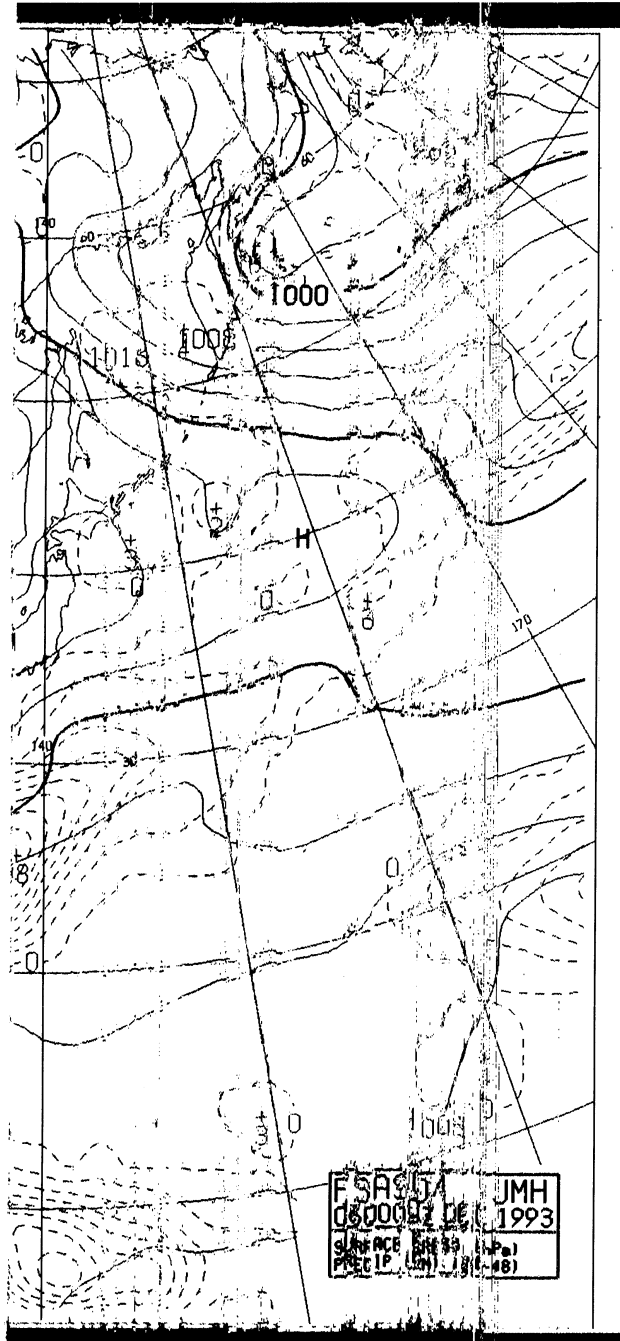

Appendix Figure 9 Interfered reception example
(by the use of the Automatic Frequency Selection function)

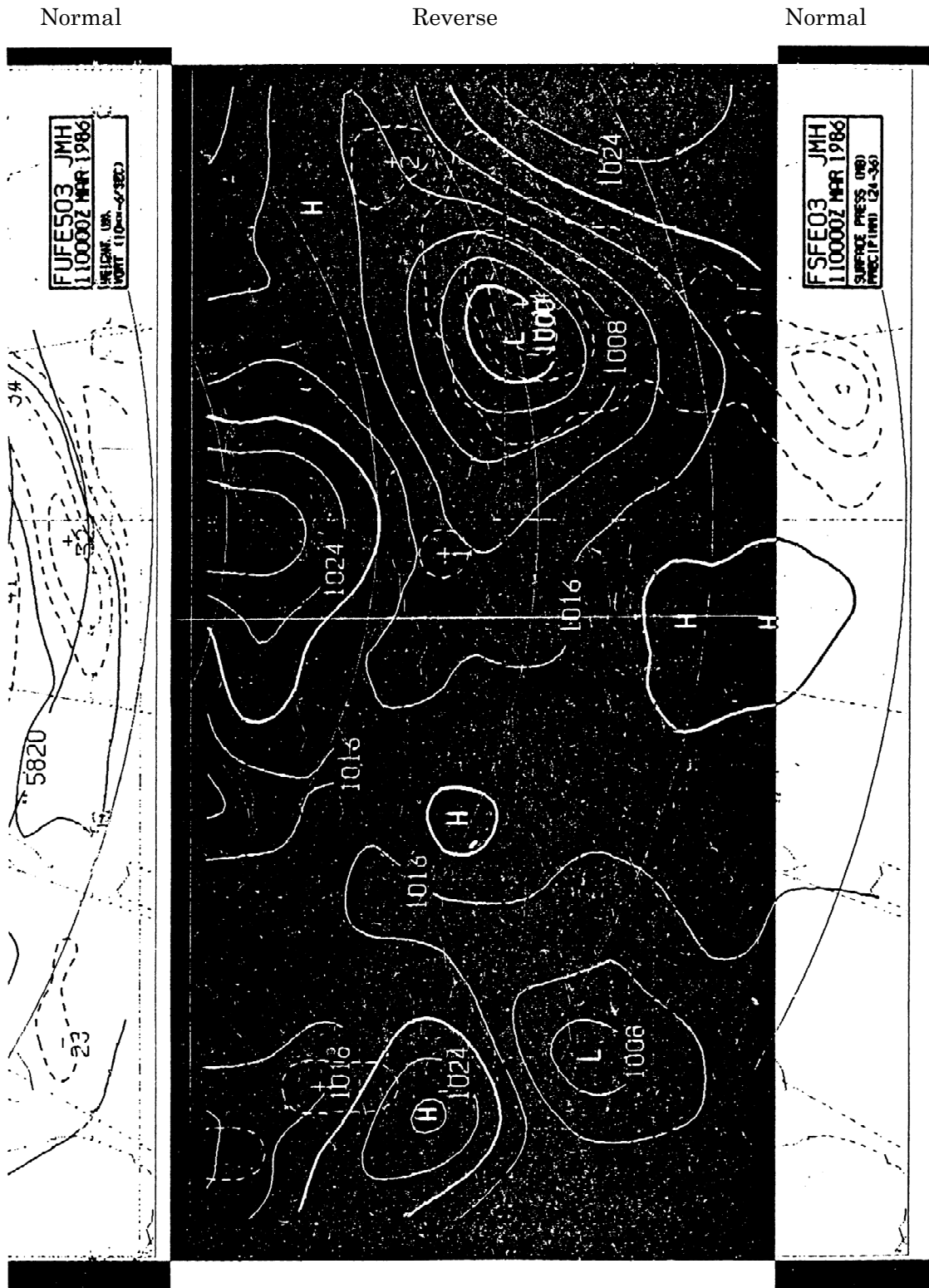

Appendix Figure 10 Reception example
(by the false selection of the Black/White Inversion function)

アスベストは使用しておりません
Not use the asbestos

CODE No.7ZPNA4036D

For further information, contact:

JRC

Since 1915

Japan Radio Co., Ltd.

URL <http://www.jrc.co.jp>

Marine Service Department

Telephone : +81-3-3492-1305

Facsimile : +81-3-3779-1420

e-mail : tmisc@jrc.co.jp

AMSTERDAM Branch

Telephone : +31-20-658-0750

Facsimile : +31-20-658-0755

e-mail : service@jrceurope.com

SEATTLE Branch

Telephone : +1-206-654-5644

Facsimile : +1-206-654-7030

e-mail : marineservice@jrcamerica.com

01ETM

ISO 9001, ISO 14001 Certified

©APR. 2012 Edition 5 JRC

Printed in Japan